

Teknik Makina 1987 yılında otomotiv sektöründe imalat hayatına başlamıştır. Bir süre bu sektörde hizmet verdikten sonra 1994'te sektör değiştirerek, kesici takımlar imalatına adım atmıştır. Yaklaşık 5000'i aşkın ürün çeşidi ile geniş bir üretime sahiptir. Kurulduğundan bu güne kadar performans, kalite ve maliyet olarak en iyi ürünlerle hizmet vermeye devam etmektedir.

Kuruluşundan bu yana yüksek teknolojiye , yeniliklere, yeni projelere açık olup kendisini sürekli yenilemektedir.

Ürünlerinin ve hizmetinin kalitesini arttırarak ISO9001:2015 belgesini almış; müşterilerinin var olan güvenini daha da pekiştirmiştir. Kısa ve uzun vadeli oluşturulmuş kalkınma plânlarıyla yıllık üretim adetlerini yükseltmeyi hedefleyen TEKNİK MAKİNA konusunda uzman çalışanları ile ilk günkü heyecan ve istekle çalışmalarını sürdürerek dünya ve Türkiye pazarındaki yerini daha da sağlamlaştırarak yükselen grafiğini aynı istikrarda yürütmeye ve ülke ekonomisine katkılarını sürdürmekte kararlıdır.



Technical solution quality

Kalite için TEKNİK Çözüm

Teknik Cutting tools has been established in 1987 in Turkey. Teknik Cutting Tools started to produce cutting tools in 1994. Over 5.000 kinds of tools are produced in the factory building located in the Fourth Industrial Area of Konya since 2015. Teknik Cutting Tools is a very experienced producer a large range of a Cutting Tools: Face Mill, End Mill, Boring Bars, External Turning Holders and more. There are 40 production lines which are capable to produce in several categories at the same time.











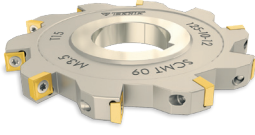

We keep up to date with new products and when customers need special tools we do all we can to produce the tools to meet their expectations.

Production and designing teams are all educated and certified according to the ISO 9001:2015 quality standard to serve you better.

The Company Headquarters is also located in Konya.

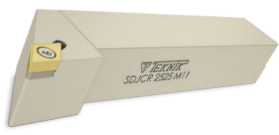

Konya and Istanbul branches are dedicated with marketing and sales. Teknik Cutting Tools does international trade as cutting tools exporter with many countries all around the World and offers the highest level of quality, service and reliability, in a very short lead-time with the best Fiyat, guaranteed.

Sayfa	Ürün Tipi	
6-23	Tarama Başlığı	
26-30	Baralar	
32-33	Helis Freze - Disk Freze	
36-38	T-Kanal Freze	
40-45	Saplı Tarama - Küre Uçlu Freze	
58-61	Vidalı Takım	
64-68	Diş Katerleri	
70-73	P Sistem Kater Soğutmalı	
76-77	P Sistem Kater	
80-85	D Diş Çap Kater	
88-94	S Sistem Diş Çap Kater	
96-99	P Sistem İç Çap Kater	
102-105	D Sistem İç Çap Kater	

Sayfa	Ürün Tipi	
108-115	S Sistem İç Çap Kater	
118-120	Karbür Takımlar ve Setler	
122-123	İç Çap Kater Set	
126-135	U-Drill	
138-144	Kanal Kater - Keski Kütüğü	
146-148	İç Çap Kanal Kater	
148	Takım Tutucuları	
152-155	Yedek Parça	
156-157	Kesme Verileri - ISO Kodları	
	Cutting Data- ISO Kod	
	Schnittdaten - ISO Kod	

Kalite için TEKNİK Çözüm

Technical solution for quality



Tarama Başlıkları
Havşa



www.teknicuttingtools.com



Kalite için TEKNİK çözüm
Technical solution for quality

6-23

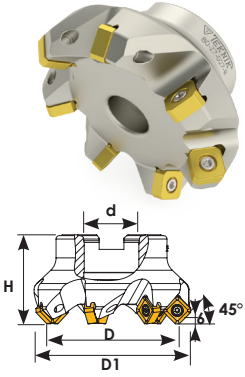

45° SNKX 1206

Sipariş Kodu	Ürün Kodu	Ölçüler (mm)						Uç	Fiyat
		D	D1	d	Z	H	kg		
T319	D040 d16 Z03 SNKX 12	40	53	16	3	45	0,417		₺914
T320	D050 d22 Z04 SNKX 12	50	63	22	4	44	0,593		₺1.080
T322	D063 d22 Z06 SNKX 12	63	76	22	6	44	0,710	SNKX 1206	₺1.629
T325	D080 d27 Z07 SNKX 12	80	93	27	7	52	1,334		₺1.886
T330	D100 d32 Z08 SNKX 12	100	113	32	8	52	1,926		₺2.183
T332	D125 d40 Z10 SNKX 12	125	138	40	10	63	3,780		₺2.917
T334	D160 d40 Z12 SNKX 12	160	173	40	12	63	5,380		₺3.689
T335	D200 d60 Z14 SNKX 12	200	213	60	14	63	6,690		₺4.918
		TC076 M4x12,5		T15					

KRLY-PLBT-BHLR Ucuna Uygun.

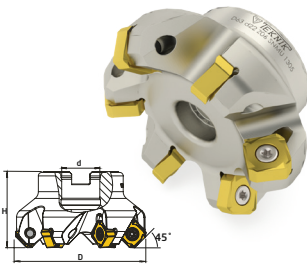
45° SNMU 1305

Sipariş Kodu	Ürün Kodu	Ölçüler (mm)					Uç	Fiyat	
		D	d	Z	H	kg			
T234	D050 d22 Z04 SNMU 13	50	22	4	44	0,480		₺1.080	
T235	D063 d22 Z06 SNMU 13	63	22	6	44	0,645	SNMU 1305	₺1.629	
T236	D080 d27 Z07 SNMU 13	80	27	7	52	1,147	ISCR	₺1.886	
T237	D100 d32 Z08 SNMU 13	100	32	8	52	1,487		₺2.183	
T238	D125 d40 Z10 SNMU 13	125	40	10	63	3,610		₺2.917	
		TC083 M5x12		T20					

ISCR Ucuna Uygun.

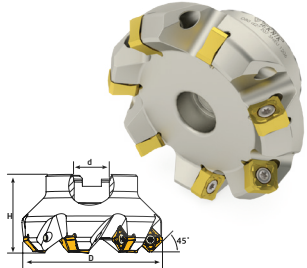
45° SNEU 1206

Sipariş Kodu	Ürün Kodu	Ölçüler (mm)					Uç	Fiyat	
		D	d	Z	H	kg			
T164	D050 d22 Z05 SNEU 12	50	22	5	40	0,447		₺1.347	
T165	D063 d22 Z06 SNEU 12	63	22	6	40	0,582	SNEU 1206	₺1.629	
T166	D080 d27 Z07 SNEU 12	80	27	7	50	1,252		₺1.886	
T167	D100 d32 Z08 SNEU 12	100	32	8	50	1,925		₺2.183	
T168	D125 d40 Z10 SNEU 12	125	40	10	63	3,516		₺2.917	
		TC083 M5x12		T20					

XTC-GSC-WLTR Ucuna Uygun.

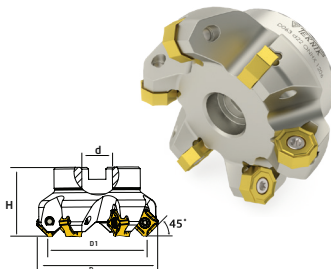
45° SNKX 1206-ONHX 0505



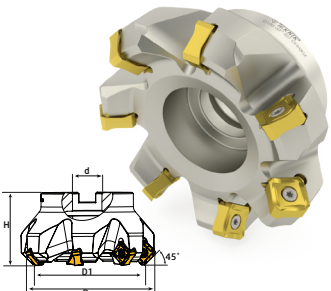

Sipariş Kodu	Ürün Kodu	Ölçüler (mm)						Uç	Fiyat
		D	D1	d	Z	H	kg		
T623	D050 d22 Z04 SNKX 12 ONHX 05	50	42,4	22	4	40	0,458		₺1.080
T624	D063 d22 Z06 SNKX 12 ONHX 05	63	55,4	22	6	40	0,608	SNKX 1206	₺1.629
T625	D080 d27 Z07 SNKX 12 ONHX 05	80	72,4	27	7	50	1,051	ONHX 0505	₺1.886
T626	D100 d32 Z08 SNKX 12 ONHX 05	100	92,4	32	8	50	1,813	PLBT	₺2.183
T627	D125 d40 Z10 SNKX 12 ONHX 05	125	117,4	40	10	63	3,277		₺2.917
T628	D160 d40 Z12 SNKX 12 ONHX 05	160	152,4	40	12	63	4,577		₺3.728
		TC074 M4x10		T15					





PLBT Ucuna Uygun.

45° SNKX 1606-ONHX 0606







Sipariş Kodu	Ürün Kodu	Ölçüler (mm)						Uç	Fiyat
		D	D1	d	Z	H	kg		
T629	D063 d22 Z05 SNKX 16 ONHX 06	63	63	22	5	50	0,776		₺1.347
T630	D080 d27 Z06 SNKX 16 ONHX 06	80	80	27	6	50	2,013	SNKX 1606	₺1.629
T631	D100 d32 Z07 SNKX 16 ONHX 06	100	100	32	7	63	2,750	ONHX 0606	₺1.924
T632	D125 d40 Z08 SNKX 16 ONHX 06	125	125	40	8	63	4,026	PLBT	₺2.321
T633	D160 d40 Z10 SNKX 16 ONHX 06	160	160	40	10	63	4,712		₺3.093
T634	D200 d60 Z12 SNKX 16 ONHX 06	200	200	60	12	63	8,112		₺4.362
		TC083 M5x12		T20					

PLBT Ucuna Uygun.





Sipariş Kodu	Ürün Kodu	Ölçüler (mm)						Uç	Fiyat
		D	D1	d	Z	H			
T300	D063 d22 Z05 SDHT 12	63	77	22	5	45	0,630		₺1.152
T302	D080 d27 Z06 SDHT 12	80	94	27	6	52	1,200	SDHT 1204	₺1.347
T304	D100 d32 Z07 SDHT 12	100	114	32	7	62	2,040	ISO	₺1.629
T305	D125 d40 Z08 SDHT 12	125	139	40	8	62	4,095		₺2.183
			TC080 M4,5x11			T15			

Sipariş Kodu	Ürün Kodu	Ölçüler (mm)					Uç	Fiyat	
		D	d	Z	H				
T435	D063 d22 Z05 SEET 12	63	22	5	50	0,815		₺1.152	
T436	D080 d27 Z06 SEET 12	80	27	6	52	1,305	SEET 12T3	₺1.347	
T437	D100 d32 Z07 SEET 12	100	32	7	55	1,715	R245	₺1.629	
T438	D125 d40 Z08 SEET 12	125	40	8	62	3,427		₺2.103	
			TC067 M3,5x8,5			T15			





ZCC -SNDVK-XTC Ucuna Uygundur.

Sipariş Kodu	Ürün Kodu	Ölçüler (mm)					Uç	Fiyat	
		D	d	Z	H				
T560	D050 d22 Z04 SEET 12	50	22	4	40	0,345		₺1.429	
T562	D063 d22 Z05 SEET 12	63	22	5	40	0,505	SEET 12T3	₺1.629	
T564	D080 d27 Z06 SEET 12	80	27	6	50	1,206	R245	₺1.886	
T566	D100 d32 Z07 SEET 12	100	32	7	50	1,812		₺2.103	
T568	D125 d40 Z08 SEET 12	125	40	8	63	3,390		₺2.539	
T570	D160 d40 Z10 SEET 12	160	40	10	63	4,590		₺3.374	
				TA052		TC049 M5x7		T15	

ZCC -SNDVK-XTC Ucuna Uygundur.

Sipariş Kodu	Ürün Kodu	Ölçüler (mm)					Uç	Fiyat	
		D	d	Z	H				
T780	D063 d22 Z05 ONMX 08	63	22	5	40	1,063	ONMX 0806 KRL	₺1.347	
T782	D080 d27 Z06 ONMX 08	80	27	6	50	0,532	ONMX 0806 ISCR	₺1.629	
T784	D100 d32 Z07 ONMX 08	100	32	7	50	1,067	ONMU 0806 YG1	₺1.924	
T786	D125 d40 Z08 ONMX 08	125	40	8	63	3,574	ONKX 0806 LMN	₺2.400	
			TC083 M5x12			T20			

KRLY-ISCR-YG1-LMN Ucuna Uygundur.

Sipariş Kodu	Ürün Kodu	Ölçüler (mm)					Uç	Fiyat	
		D	d	Z	H				
T790	D063 d22 Z05 ONMX 06	63	22	5	45	0,657		₺1.347	
T791	D080 d27 Z06 ONMX 06	80	27	6	50	1,110	ONMX 0606	₺1.629	
T792	D100 d32 Z07 ONMX 06	100	32	7	52	1,701	KRLY	₺1.924	
			TC083 M5x12			T20			

KRLY Ucuna Uygundur.

55° HNHX 1006

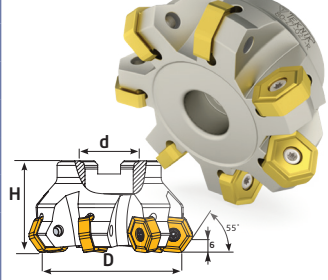

TGTC Ucuna Uygundur

Sipariş Kodu	Ürün Kodu	Ölçüler (mm)					Uç	Fiyat
		D	d	Z	H	kg		
T470	D063 d22 Z05 HNHX 10	63	22	5	50	0,675		₺1.347
T472	D080 d27 Z07 HNHX 10	80	27	7	50	1,063	HNHX 1006	₺1.886
T474	D100 d32 Z09 HNHX 10	100	32	9	62	2,023	TGTC	₺2.457
T476	D125 d40 Z10 HNHX 10	125	40	10	62	3,331		₺2.935
T478	D160 d40 Z12 HNHX 10	160	40	12	62	4,724		₺3.728
		TC083 M5x12		T20				

PNMU 1206

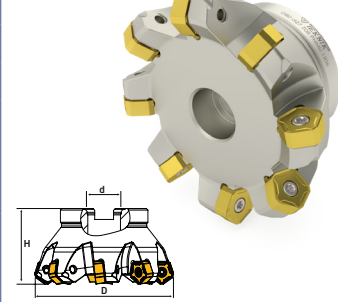

YG1 Ucuna Uygundur.

Sipariş Kodu	Ürün Kodu	Ölçüler (mm)					Uç	Fiyat
		D	d	Z	H	kg		
T722	D050 d22 Z04 PNMU 12	50	22	4	40	0,371		₺1.080
T723	D063 d22 Z05 PNMU 12	63	22	5	40	0,594	PNMU 1206	₺1.347
T724	D080 d27 Z08 PNMU 12	80	27	8	50	1,273	YG1	₺2.048
T725	D100 d32 Z10 PNMU 12	100	32	10	50	1,901		₺2.633
T726	D125 d40 Z10 PNMU 12	125	40	10	63	4,070		₺2.935
		TC074 M4x10		T15				

45° ONMU 0505

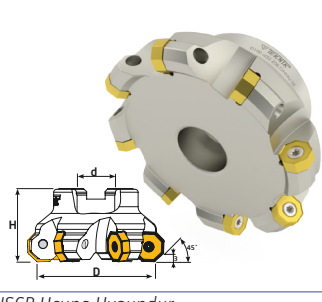

ISCR Ucuna Uygundur.

Sipariş Kodu	Ürün Kodu	Ölçüler (mm)					Uç	Fiyat
		D	d	Z	H	kg		
T794	D063 d22 Z06 ONMU 05	63	22	6	45	0,652		₺1.629
T796	D080 d27 Z07 ONMU 05	80	27	7	50	1,202	ONMU 0505	₺1.886
T798	D100 d32 Z08 ONMU 05	100	32	8	52	1,842	ISCR	₺2.183
T800	D125 d40 Z10 ONMU 05	125	40	10	62	3,537		₺2.917
T801	D160 d40 Z12 ONMU 05	160	40	12	62	4,863		₺3.712
		TC085 M5x12		T20				

55° HNGX 0906

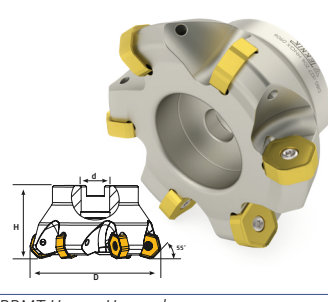

PRMT Ucuna Uygundur.

Sipariş Kodu	Ürün Kodu	Ölçüler (mm)					Uç	Fiyat
		D	d	Z	H	kg		
T418	D063 d22 Z06 HNGX 09	63	22	6	40	0,518		₺1.629
T419	D080 d27 Z06 HNGX 09	80	27	6	50	1,067	HNGX 0906	₺1.629
T420	D100 d32 Z08 HNGX 09	100	32	8	50	1,542	PRMT	₺2.183
T421	D125 d40 Z08 HNGX 09	125	40	8	63	3,314		₺2.419
T422	D160 d40 Z12 HNGX 09	160	40	12	63	3,962		₺3.712
		TC080 M4,5x11		T15				

43° ODHT 0605

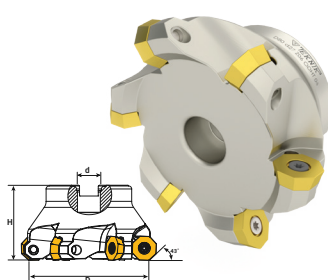

WLTR Ucuna Uygundur.

Sipariş Kodu	Ürün Kodu	Ölçüler (mm)					Uç	Fiyat
		D	d	Z	H	kg		
T210	D063 d22 Z05 ODHT 06	63	22	5	40	0,610		₺1.269
T211	D080 d27 Z06 ODHT 06	80	27	6	50	1,070	ODHT 0605	₺1.586
T212	D100 d32 Z07 ODHT 06	100	32	7	52	1,765	WLTR	₺1.886
T213	D125 d40 Z08 ODHT 06	125	40	8	62	3,528		₺2.419
		TC083 M5x12		T20				

43° OFCR 0704

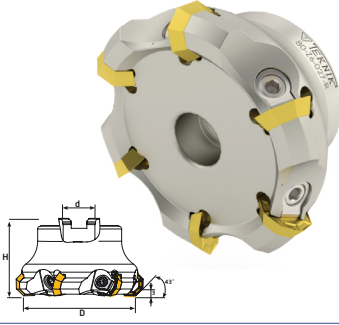

Sipariş Kodu	Ürün Kodu	Ölçüler (mm)					Uç	Fiyat
		D	d	Z	H	kg		
T260	D050 d22 Z04 OFCR 07	50	22	4	45	0,488		₺1.080
T262	D063 d22 Z04 OFCR 07	63	22	4	45	0,722	OFCR 0704	₺1.347
T264	D080 d27 Z06 OFCR 07	80	27	6	50	1,205	ISO	₺1.629
T266	D100 d32 Z08 OFCR 07	100	32	8	50	1,654		₺2.183
T268	D125 d40 Z09 OFCR 07	125	40	9	62	3,510		₺2.617
T269	D160 d40 Z12 OFCR 07	160	40	12	62	5,112		₺3.712
		BK300	TC300 M8x18	4 Allen				

90° XNEX 0806

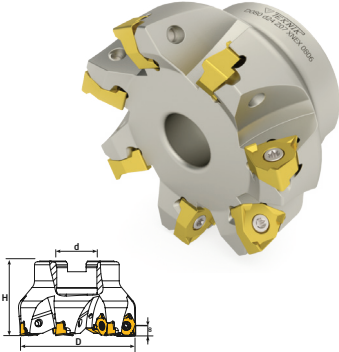

Sipariş Kodu	Ürün Kodu	Ölçüler (mm)					Uç	Fiyat
		D	d	Z	H	kg		
T840	D050 d22 Z04 XNEX 08	50	22	4	45	0,400		₺1.080
T841	D050 d22 Z05 XNEX 08	50	22	5	45	0,394		₺1.347
T842	D063 d22 Z06 XNEX 08	63	22	6	45	0,490	XNEX 0806 SCO	₺1.629
T844	D080 d27 Z07 XNEX 08	80	27	7	50	1,063	XNEX 0806 WNST	₺1.886
T846	D100 d32 Z07 XNEX 08	100	32	7	52	1,755		₺1.924
T848	D125 d40 Z10 XNEX 08	125	40	10	60	3,155		₺2.917
T850	D160 d40 Z12 XNEX 08	160	40	12	63	5,154		₺3.689
T851	D200 d60 Z14 XNEX 08	200	60	14	63	6,415		₺4.918
		TC076 M4x12,5	T15					

SCO-WNST Ucuna Uygunur.

90° WNGX 0806

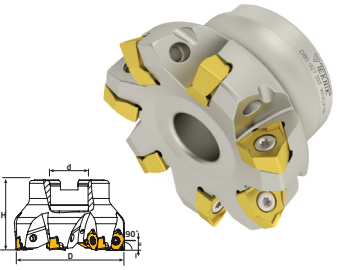

Sipariş Kodu	Ürün Kodu	Ölçüler (mm)					Uç	Fiyat
		D	d	Z	H	kg		
T775	D050 d22 Z05 WNGX 08	50	22	5	40	0,277		₺1.347
T776	D063 d22 Z06 WNGX 08	63	22	6	40	0,470	WNGX 0806	₺1.629
T777	D080 d27 Z07 WNGX 08	80	27	7	50	1,105	KRLY	₺1.886
T778	D100 d32 Z08 WNGX 08	100	32	8	52	1,580		₺2.183
		TC083 M5x12	T20					

KRLY Ucuna Uygunur.

90° WNGX 0403

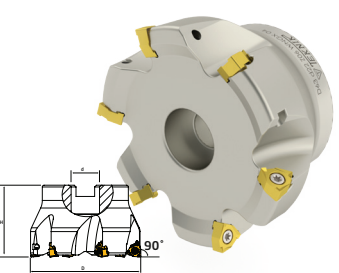

Sipariş Kodu	Ürün Kodu	Ölçüler (mm)					Uç	Fiyat
		D	d	Z	H	kg		
T692	D040 d16 Z06 WNGX 04	40	16	6	40	0,256		₺1.629
T693	D050 d22 Z08 WNGX 04	50	22	8	40	0,347	WNGX 0403	₺2.028
T694	D063 d22 Z10 WNGX 04	63	22	10	40	0,617	KRLY	₺2.535
T695	D080 d27 Z11 WNGX 04	80	27	11	50	1,306		₺2.730
		TC060 M2,5x5,5	T8					

KRLY Ucuna Uygunur.

90° WNMU 0705

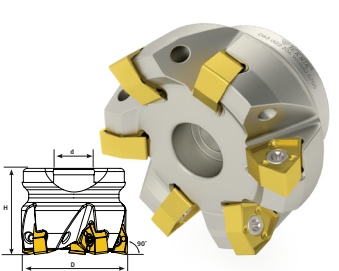

Sipariş Kodu	Ürün Kodu	Ölçüler (mm)					Uç	Fiyat
		D	d	Z	H	kg		
T392	D050 d22 Z05 WNMU 07	50	22	5	40	0,337		₺1.347
T393	D063 d22 Z06 WNMU 07	63	22	6	40	0,515	WNMU 0705	₺1.629
T394	D080 d27 Z07 WNMU 07	80	27	7	50	1,012	ISC	₺1.886
T395	D100 d32 Z08 WNMU 07	100	32	8	50	1,342		₺2.183
		TC074 M4x10	T15					

ISC Ucuna Uygunur.

90° WNMU 0806

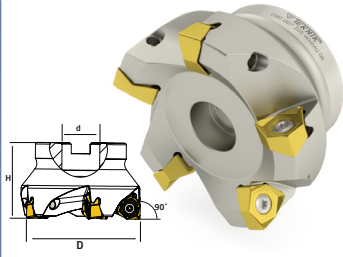

Sipariş Kodu	Ürün Kodu	Ölçüler (mm)					Uç	Fiyat
		D	d	Z	H	kg		
T543	D050 d22 Z03 WNMU 08	50	22	3	46	0,360		₺914
T544	D063 d22 Z04 WNMU 08	63	22	4	46	0,556	WNMU 0806	₺1.080
T545	D080 d27 Z05 WNMU 08	80	27	5	50	1,016	KYCRA	₺1.347
T546	D100 d32 Z06 WNMU 08	100	32	6	50	1,360		₺1.648
		TC083 M5x12		T20				

KYCRA Ucuna Uygundur.

88° SNMX 1206

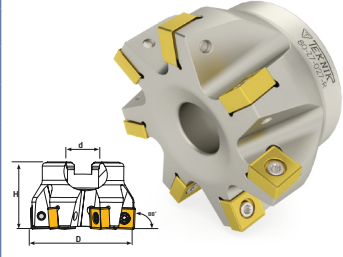

Sipariş Kodu	Ürün Kodu	Ölçüler (mm)					Uç	Fiyat
		D	d	Z	H	kg		
T344	D063 d22 Z06 SNMX 12	63	22	6	40	0,574		₺1.629
T345	D080 d27 Z07 SNMX 12	80	27	7	50	1,213	SNMX 1206	₺1.886
T346	D100 d32 Z08 SNMX 12	100	32	8	50	1,688	KRLY	₺2.183
		TC076 M4x12,5		T15				

KRLY Ucuna Uygundur.

88° SNHU 1206

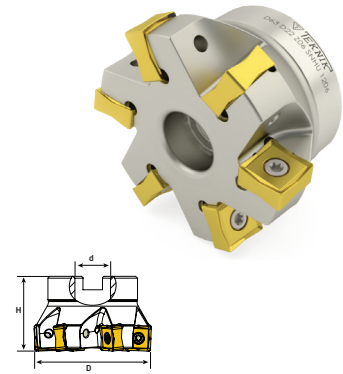

Sipariş Kodu	Ürün Kodu	Ölçüler (mm)					Uç	Fiyat
		D	d	Z	H	kg		
T616	D050 d22 Z04 SNHU 12	50	22	4	40	0,298		₺1.080
T617	D050 d22 Z05 SNHU 12	50	22	5	40	0,305		₺1.152
T617-1	D063 d22 Z05 SNHU 12	63	22	5	40	0,472	SNHU 1206	₺1.347
T618	D063 d22 Z06 SNHU 12	63	22	6	40	0,503	PLBT	₺1.629
T618-1	D080 d27 Z06 SNHU 12	80	27	6	50	0,968		₺1.629
T619	D080 d27 Z07 SNHU 12	80	27	7	50	1,076		₺1.886
T620	D100 d32 Z08 SNHU 12	100	32	8	50	1,459		₺2.183
T621	D125 d40 Z10 SNHU 12	125	40	10	63	2,708		₺2.917
T622	D160 d40 Z12 SNHU 12	160	40	12	63	4,328		₺3.728
		TC074 M4x10		T15				

PLBT Ucuna Uygundur

90° SPMT 1204

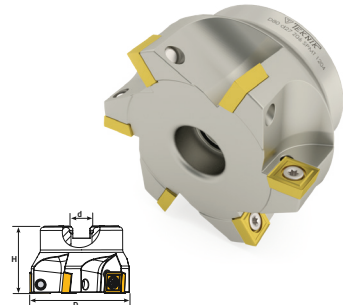

Sipariş Kodu	Ürün Kodu	Ölçüler (mm)					Uç	Fiyat
		D	d	Z	H	kg		
T649	D040 d16 Z03 SPMT 12	40	16	3	40	0,253		₺714
T650	D050 d22 Z04 SPMT 12	50	22	4	40	0,362		₺914
T651	D063 d22 Z05 SPMT 12	63	22	5	50	0,772		₺1.152
T652	D080 d27 Z06 SPMT 12	80	27	6	50	1,186	SPMT 1204	₺1.347
T653	D100 d32 Z08 SPMT 12	100	32	8	50	1,786		₺1.825
T654	D125 d40 Z08 SPMT 12	125	40	8	63	2,935		₺2.046
T655	D160 d40 Z10 SPMT 12	160	40	10	63	3,980		₺2.917
		TC083 M5x12		T20				

PLBT-ZCC-WLTR Ucuna Uygundur.

90° SPMG 0904

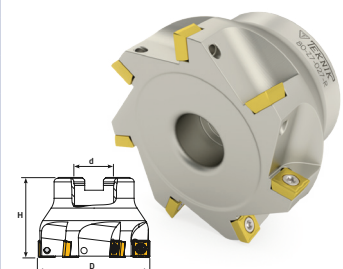

Sipariş Kodu	Ürün Kodu	Ölçüler (mm)					Uç	Fiyat
		D	d	Z	H	kg		
T338	D050 d22 Z05 SPMG 09	50	22	5	45	0,239	SPMG 0904	₺1.152
T340	D063 d22 Z06 SPMG 09	63	22	6	45	0,362	TGTC	₺1.347
T342	D080 d27 Z07 SPMG 09	80	27	7	52	1,088		₺1.547
		TC067 M3,5x8,5		T15				

TGTC Ucuna Uygundur.

90° LNMX 1006

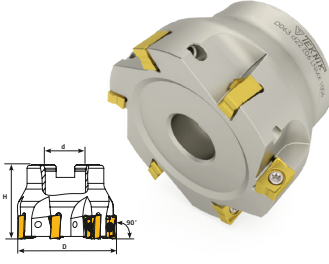

KRLY Ucuna Uygundur.

Sipariş Kodu	Ürün Kodu	Ölçüler (mm)					Uç	Fiyat
		D	d	Z	H	kg		
T386	D040 d16 Z05 LNMX 10	40	16	5	40	0,258		₺1.347
T387	D050 d22 Z06 LNMX 10	50	22	6	45	0,472	LNMX 1006	₺1.629
T388	D063 d22 Z06 LNMX 10	63	22	6	45	0,495	KRLY	₺1.629
T389	D080 d27 Z07 LNMX 10	80	27	7	50	0,731		₺1.886
T390	D100 d32 Z09 LNMX 10	100	32	9	50	1,700		₺2.418
		TC065 M3x7		T8				

90° LNMX 1510

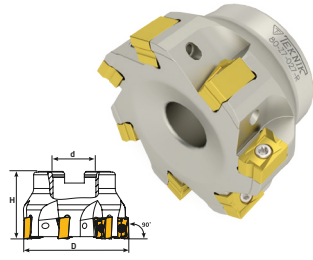

KRLY ucuna uygundur.

Sipariş Kodu	Ürün Kodu	Ölçüler (mm)					Uç	Fiyat
		D	d	Z	H	kg		
T372	D050 d22 Z04 LNMX 15	50	22	4	45	0,375		₺1.080
T374	D063 d22 Z06 LNMX 15	63	22	6	45	0,616		₺1.629
T376	D080 d27 Z07 LNMX 15	80	27	7	50	1,087	LNMX 1510	₺1.886
T378	D100 d32 Z08 LNMX 15	100	32	8	52	1,644	KRLY	₺2.183
T380	D125 d40 Z10 LNMX 15	125	40	10	63	3,650		₺2.917
		TC076 M4x12,5		T15				

90° ANKX 1205

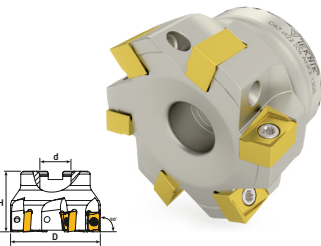

ISCR Ucuna Uygundur.

Sipariş Kodu	Ürün Kodu	Ölçüler (mm)					Uç	Fiyat
		D	d	Z	H	kg		
T571	D040 d16 Z04 ANKX 12	40	16	4	40	0,215		₺1.080
T572	D050 d22 Z05 ANKX 12	50	22	5	45	0,433	ANKX 1205	₺1.347
T574	D063 d22 Z06 ANKX 12	63	22	6	45	0,596	ISCR	₺1.629
T576	D080 d27 Z07 ANKX 12	80	27	7	50	1,210		₺1.886
		TC074 M4x10		T15				

90° ANKX 1706

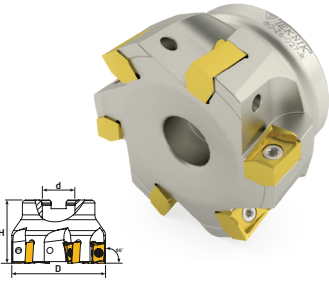

ISCR Ucuna Uygundur.

Sipariş Kodu	Ürün Kodu	Ölçüler (mm)					Uç	Fiyat
		D	d	Z	H	kg		
T440	D040 d16 Z03 ANKX 17	40	16	3	45	0,279		₺914
T442	D050 d22 Z04 ANKX 17	50	22	4	45	0,371	ANKX 1706	₺1.080
T444	D063 d22 Z05 ANKX 17	63	22	5	45	0,573	ISCR	₺1.347
T446	D080 d27 Z06 ANKX 17	80	27	6	52	1,238		₺1.629
T448	D100 d32 Z07 ANKX 17	100	32	7	52	2,029		₺1.924
T450	D125 d40 Z08 ANKX 17	125	40	8	63	3,590		₺2.379
		TC083 M5x12		T20				

90° ANHX 1004

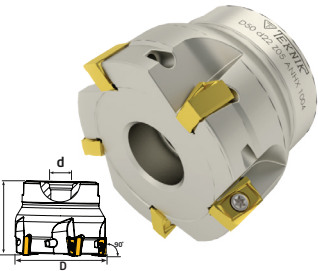

PLBT Ucuna Uygundur.

Sipariş Kodu	Ürün Kodu	Ölçüler (mm)					Uç	Fiyat
		D	d	Z	H	kg		
T656	D040 d16 Z04 ANHX 10	40	16	4	40	0,250		₺1.080
T657	D050 d22 Z05 ANHX 10	50	22	5	40	0,374	ANHX 1004	₺1.347
T658	D063 d22 Z07 ANHX 10	63	22	7	40	0,638	PLBT	₺1.872
T659	D080 d27 Z08 ANHX 10	80	27	8	50	1,132		₺2.126
		TC065 M3x7		T8				

90° ANHX 1206

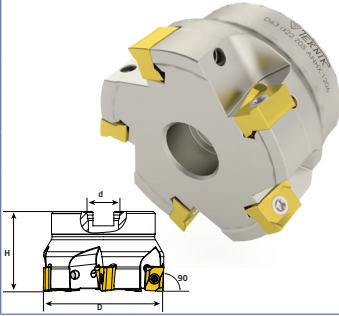

PLBT Ucuna Uygundur.

Sipariş Kodu	Ürün Kodu	Ölçüler (mm)					Uç	Fiyat
		D	d	Z	H	kg		
T641	D040 d16 Z04 ANHX 12	40	16	4	40	0,248		₺1.080
T642	D050 d22 Z05 ANHX 12	50	22	5	40	0,375		₺1.347
T643	D063 d22 Z05 ANHX 12	63	27	5	40	0,619	ANHX 1206	₺1.347
T644	D080 d27 Z08 ANHX 12	80	27	8	50	1,209	PLBT	₺2.103
T645	D100 d32 Z12 ANHX 12	100	32	12	50	1,761		₺3.115
T646	D125 d40 Z14 ANHX 12	125	40	14	63	3,091		₺3.611

 TC069 M3,5x8,5

 T10



90° ANKX 1607

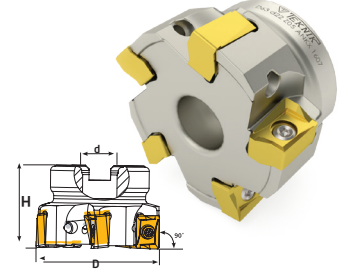

XTC- GSC Ucuna Uygundur

Sipariş Kodu	Ürün Kodu	Ölçüler (mm)					Uç	Fiyat
		D	d	Z	H	kg		
T171	D050 d22 Z04 ANKX 16	50	22	4	40	0,307		₺1.080
T172	D063 d22 Z05 ANKX 16	63	22	5	40	0,462	ANKX 1607	₺1.347
T173	D080 d27 Z06 ANKX 16	80	27	6	50	1,101		₺1.629

 TC080-1 M4,5x11

 T15



90° LNGX 1307

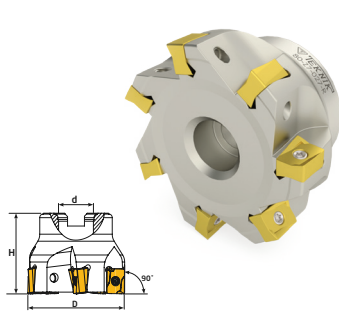

WLTR Ucuna Uygundur.

Sipariş Kodu	Ürün Kodu	Ölçüler (mm)					Uç	Fiyat
		D	d	Z	H	kg		
T488	D040 d16 Z03 LNGX 13	40	16	3	45	0,304		₺914
T490	D050 d22 Z04 LNGX 13	50	22	4	45	0,425		₺1.080
T492	D063 d22 Z06 LNGX 13	63	22	6	45	0,560	LNGX 1307	₺1.629
T493	D080 d27 Z07 LNGX 13	80	27	7	50	1,124	WLTR	₺1.886
T494	D100 d32 Z07 LNGX 13	100	32	7	50	1,542		₺1.924
T495	D125 d40 Z08 LNGX 13	125	40	8	63	3,555		₺2.419

 TC079 M4x10

 T15



90° LNGU 15T6

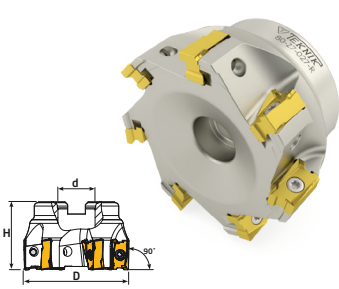

KNNMTL Ucuna Uygundur

Sipariş Kodu	Ürün Kodu	Ölçüler (mm)					Uç	Fiyat
		D	d	Z	H	kg		
T956	D050 d22 Z05 LNGU 15	50	22	5	40	0,305		₺1.347
T958	D063 d22 Z06 LNGU 15	63	22	6	40	0,541	LNGU 15T6	₺1.629
T960	D080 d27 Z07 LNGU 15	80	27	7	50	1,133	KNNMTL	₺1.924
T961	D100 d32 Z08 LNGU 15	100	32	8	50	1,933		₺2.183

 TC074 M4x10

 T15



90° LNHU 1306

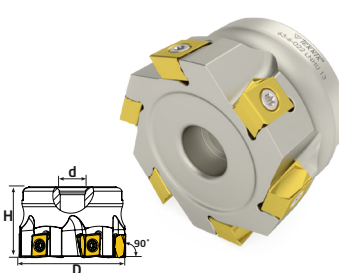





WLTR Ucuna Uygundur.

Sipariş Kodu	Ürün Kodu	Ölçüler (mm)					Uç	Fiyat
		D	d	Z	H	kg		
T580	D050 d22 Z05 LNHU 13	50	22	5	40	0,350		₺1.152
T581	D063 d22 Z06 LNHU 13	63	22	6	40	0,628	LNHU 1306	₺1.507
T582	D080 d27 Z07 LNHU 13	80	27	7	50	1,315	WLTR	₺1.866
T583	D100 d32 Z08 LNHU 13	100	32	8	50	1,795		₺2.025

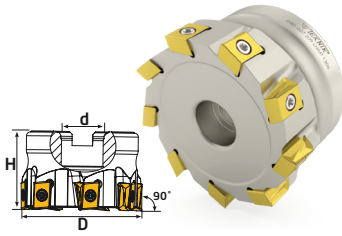

 TC079 M4x10

 T15



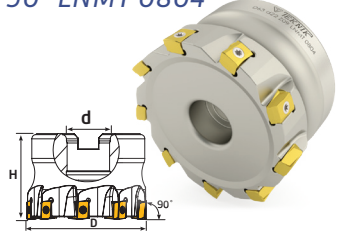

90° LNMT 1306	Sipariş Kodu	Ürün Kodu	Ölçüler (mm)					Uç	Fiyat
			D	d	Z	H	kg		
	T228	D050 d22 Z05 LNMT 13	50	22	5	40	0,337		₺1.152
	T229	D063 d22 Z06 LNMT 13	63	22	6	40	0,596	LNMT 1306	₺1.547
	T230	D080 d27 Z07 LNMT 13	80	27	7	50	1,227	ISCR	₺1.924
	T231	D100 d32 Z08 LNMT 13	100	32	8	50	1,682		₺2.142
	T232	D125 d40 Z09 LNMT 13	125	40	9	63	3,325		₺3.015
	T233	D160 d40 Z12 LNMT 13	160	40	12	63	5,046		₺3.728
					TC 074 M4x10			T15	

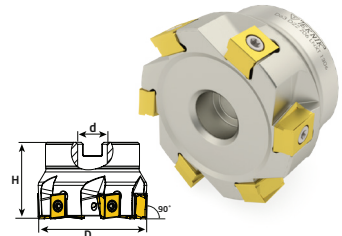

ISCR Ucuna Uygundur.

90° LNMT 0804	Sipariş Kodu	Ürün Kodu	Ölçüler (mm)					Uç	Fiyat
			D	d	Z	H	kg		
	T222	D040 d16 Z06 LNMT 08	40	16	6	40	0,240		₺1.347
	T223	D050 d22 Z07 LNMT 08	50	22	7	40	0,374	LNMT 0804	₺1.547
	T224	D063 d22 Z09 LNMT 08	63	22	9	40	0,665	ISCR	₺1.924
	T225	D080 d27 Z10 LNMT 08	80	27	10	50	1,145		₺2.142
						TC 061 M2,5x6,5			T8

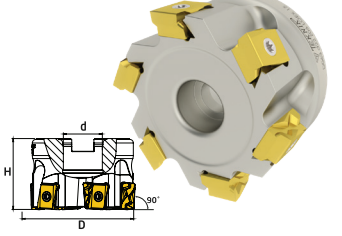

ISCR Ucuna Uygundur.

90° LNXT 1306	Sipariş Kodu	Ürün Kodu	Ölçüler (mm)					Uç	Fiyat
			D	d	Z	H	kg		
	T672	D040 d16 Z04 LNXT 13	40	16	4	40	0,225		₺914
	T673	D050 d22 Z05 LNXT 13	50	22	5	40	0,358	LNXT 1306	₺1.152
	T674	D063 d22 Z06 LNXT 13	63	22	6	40	0,604	PLBT	₺1.347
	T675	D080 d27 Z07 LNXT 13	80	27	7	50	1,029		₺1.547
	T676	D100 d32 Z08 LNXT 13	100	32	8	50	1,733		₺1.825
						TC 074 M4x10			T15

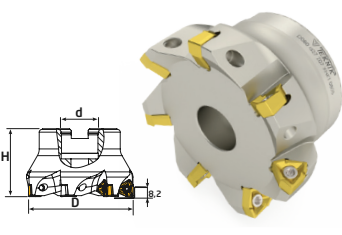

PLBT Ucuna Uygundur.

90° LOEX 1207	Sipariş Kodu	Ürün Kodu	Ölçüler (mm)					Uç	Fiyat
			D	d	Z	H	kg		
	T586	D050 d22 Z05 LOEX12	50	22	5	40	0,358	LOEX 1207	₺1.152
	T587	D063 d22 Z06 LOEX12	63	22	6	40	0,604	SCO	₺1.347
	T588	D080 d27 Z08 LOEX12	80	27	8	50	1,029		₺1.547
						TC 074 M4x10			T15

SCO Ucuna Uygundur.

90° XNKT 0805	Sipariş Kodu	Ürün Kodu	Ölçüler (mm)					Uç	Fiyat
			D	d	Z	H	kg		
	T900	D040 d16 Z04 XNKT 08	40	16	4	45	0,296		₺914
	T902	D050 d22 Z05 XNKT 08	50	22	5	45	0,396	XNKT 0805	₺1.152
	T904	D063 d22 Z06 XNKT 08	63	22	6	45	0,575	KRLY	₺1.347
	T906	D080 d27 Z07 XNKT 08	80	27	7	50	1,015		₺1.547
	T907	D100 d40 Z08 XNKT 08	100	40	8	52	1,575		₺1.825
						TC 072 M4x10			T15

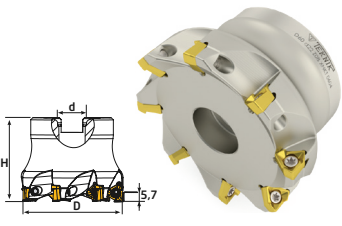
KRLY Ucuna Uygundur.

90° XNKT 0604	Sipariş Kodu	Ürün Kodu	Ölçüler (mm)					Uç	Fiyat
			D	d	Z	H	kg		
	T852	D032 d16 Z04 XNKT 06	32	16	4	40	0,150		₺914
	T853	D040 d16 Z06 XNKT 06	40	16	6	40	0,219	XNKT 0604	₺1.347
	T854	D050 d22 Z07 XNKT 06	50	22	7	40	0,348	KRLY	₺1.547
	T855	D063 d22 Z08 XNKT 06	63	22	8	40	0,527		₺1.746
	T856	D080 d27 Z10 XNKT 06	80	27	10	50	0,938		₺2.183
						TC 065-1M3x7			T8

KRLY Ucuna Uygundur.

90° 3PKT 1505

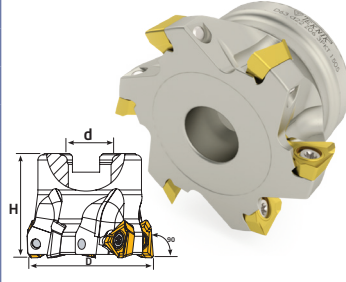

TGTC Ucuna Uygunur.

Sipariş Kodu	Ürün Kodu	Ölçüler (mm)					Uç	Fiyat
		D	d	Z	H	kg		
T398	D050 d22 Z05 3PKT 15	50	22	5	40	0,325		₺1.152
T399	D063 d22 Z06 3PKT 15	63	22	6	40	0,490	3PKT 1505	₺1.347
T400	D080 d27 Z07 3PKT 15	80	27	7	50	1,105	TGTC	₺1.547



WNMX 09T3

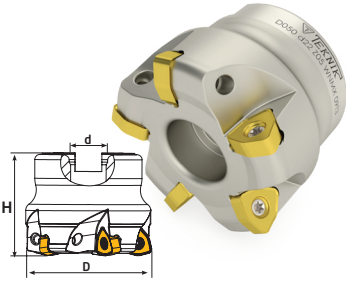

KRLY Ucuna Uygunur.

Sipariş Kodu	Ürün Kodu	Ölçüler (mm)					Uç	Fiyat
		D	d	Z	H	kg		
T669	D040 d16 Z04 WNMX 09	40	16	4	40	0,213		₺1.080
T670	D050 d22 Z05 WNMX 09	50	22	5	40	0,329	WNMX 09T3	₺1.347
T671	D063 d22 Z06 WNMX 09	63	22	6	40	0,542	KRLY	₺1.629
T671-1	D080 d27 Z06 WNMX 09	80	27	6	50	1,077		₺1.658
T671-2	D100 d32 Z07 WNMX 09	100	32	7	50	1,627		₺1.924



WNMX 1305

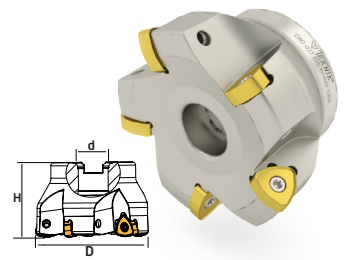

KRLY Ucuna Uygunur.

Sipariş Kodu	Ürün Kodu	Ölçüler (mm)					Uç	Fiyat
		D	d	Z	H	kg		
T687	D063 d22 Z04 WNMX 13	63	22	4	50	0,752		₺1.073
T688	D080 d27 Z05 WNMX 13	80	27	5	50	1,040	WNMX 1305	₺1.248
T689	D100 d32 Z06 WNMX 13	100	32	6	50	1,625	KRLY	₺1.492
T690	D125 d40 Z07 WNMX 13	125	40	7	63	3,716		₺2.028



100° BLMP 0603

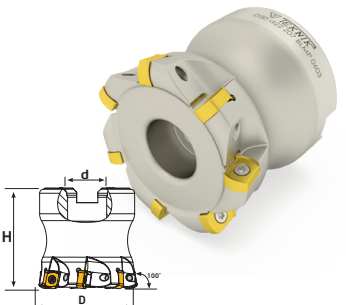

TGTC Ucuna Uygunur.

Sipariş Kodu	Ürün Kodu	Ölçüler (mm)					Uç	Fiyat
		D	d	Z	H	kg		
T480	D040 d16 Z06 BLMP 06	40	16	6	45	0,262	BLMP 0603	₺1.347
T481	D050 d22 Z07 BLMP 06	50	22	7	50	0,457	TGTC	₺1.547
T482	D052 d22 Z07 BLMP 06	52	22	7	50	0,472		₺1.547



100° BLMP 0904

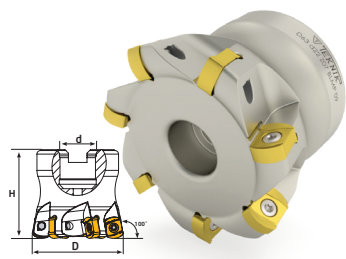

TGTC Ucuna Uygunur.

Sipariş Kodu	Ürün Kodu	Ölçüler (mm)					Uç	Fiyat
		D	d	Z	H	kg		
T485	D040 d16 Z05 BLMP 09	40	16	5	40	0,176		₺1.152
T486	D052 d22 Z06 BLMP 09	52	22	6	50	0,427	BLMP 0904	₺1.347
T487	D063 d22 Z07 BLMP 09	63	22	7	50	0,615	TGTC	₺1.547



Sipariş Kodu	Ürün Kodu	Ölçüler (mm)					Uç	Fiyat
		D	d	Z	H	kg		
T835	D032 d16 Z05 LNMX 06	32	16	5	40	0,173	LNMX 0603	₺1.347
T836	D040 d16 Z06 LNMX 06	40	16	6	40	0,279	KRLY	₺1.629
T837	D050 d22 Z08 LNMX 06	50	22	8	40	0,400		₺2.145
		TC065-1 M3x7		T8				

KRLY Ucuna Uygunur.

Sipariş Kodu	Ürün Kodu	Ölçüler (mm)					Uç	Fiyat
		D	d	Z	H	kg		
T763	D040 d16 Z06 ENMX 06	40	16	6	40	0,261	ENMX 0604	₺1.629
T764	D050 d22 Z06 ENMX 06	50	22	6	50	0,478	YG1	₺1.648
T765	D063 d22 Z07 ENMX 06	63	22	7	50	0,762		₺2.175
		TC063 M2,5x7		T8				

YG1 Ucuna Uygunur.

Sipariş Kodu	Ürün Kodu	Ölçüler (mm)					Uç	Fiyat
		D	d	Z	H	kg		
T701	D050 d22 Z04 ENMX 09	50	22	4	50	0,487		₺1.080
T702	D063 d22 Z05 ENMX 09	63	22	5	50	0,796	ENMX 0905	₺1.347
T703	D080 d27 Z08 ENMX 09	80	27	8	50	1,188	YG1	₺2.126
T704	D100 d32 Z10 ENMX 09	100	32	10	63	2,867		₺2.633
T705	D125 d40 Z12 ENMX 09	125	40	12	63	4,186		₺3.159
		TC069 M3,5x8,5		T10				

YG1 Ucuna Uygunur.

Sipariş Kodu	Ürün Kodu	Ölçüler (mm)					Uç	Fiyat
		D	d	Z	H	kg		
T728	D040 d16 Z06 LNMU 03	40	16	6	40	0,275	LNMU 0303	₺1.629
T729	D050 d22 Z07 LNMU 03	50	22	7	50	0,541	TNGLY - OKE	₺2.145
T730	D063 d22 Z09 LNMU 03	63	22	9	50	0,766		₺2.535
		TC063 M2,5x7		T8				



TNGLY-OKE Ucuna Uygunur.

Sipariş Kodu	Ürün Kodu	Ölçüler (mm)					Uç	Fiyat
		D	d	Z	H	kg		
T731	D040 d16 Z06 LOGU 03	40	16	6	40	0,283	LOGU 0303	₺1.629
T732	D050 d22 Z07 LOGU 03	50	22	7	50	0,582	KYCR	₺2.145
T734	D063 d22 Z09 LOGU 03	63	22	9	50	1,188		₺2.535
		TC064-2 M3x7		T15				

KYCR Ucuna Uygunur.

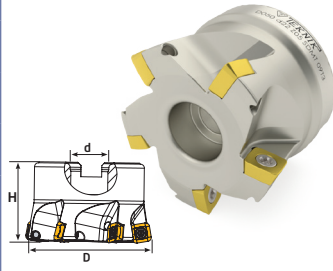
SDMT 09T3





Sipariş Kodu	Ürün Kodu	Ölçüler (mm)					Uç	Fiyat
		D	d	Z	H	kg		
T362	D040 d16 Z04 SDMT 09	40	16	4	40	0,215	SDMT 09T3	₺914
T363	D050 d22 Z05 SDMT 09	50	22	5	40	0,355	ZCC	₺1.152
T364	D063 d22 Z06 SDMT 09	63	22	6	40	0,592		₺1.347
		 TC067 M3,5x8,5		 T15				

ZCC Ucuna Uygunur.

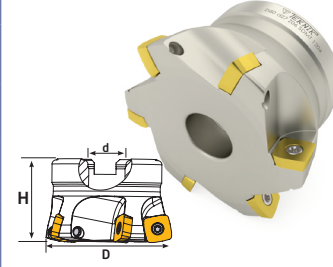
SDMT 1204





Sipariş Kodu	Ürün Kodu	Ölçüler (mm)					Uç	Fiyat
		D	d	Z	H	kg		
T358	D050 d22 Z04 SDMT 12	50	22	4	40	0,315	SDMT 1204	₺914
T359	D063 d22 Z05 SDMT 12	63	22	5	40	0,422	ZCC	₺1.152
T360	D080 d27 Z06 SDMT 12	80	27	6	52	1,051		₺1.347
		 TC074 M4x10		 T15				

ZCC Ucuna Uygunur.

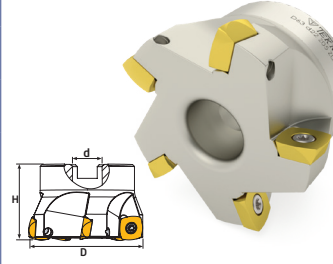
ZDEW 1204





Sipariş Kodu	Ürün Kodu	Ölçüler (mm)					Uç	Fiyat
		D	d	Z	H	kg		
T196	D050 d22 Z04 ZDEW 12	50	22	4	40	0,256	ZDEW 1204	₺993
T197	D063 d22 Z05 ZDEW 12	63	22	5	40	0,474	PRMT	₺1.269
		 TC080-1M4,5x11		 T15				

PRMT Ucuna Uygunur.

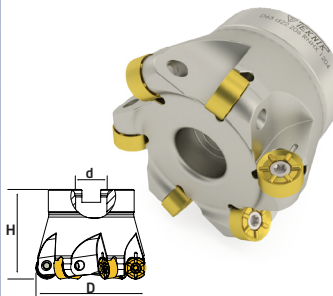
RNHX 1204





Sipariş Kodu	Ürün Kodu	Ölçüler (mm)					Uç	Fiyat
		D	d	Z	H	kg		
T661	D050 d22 Z05 RNHX 12	50	22	5	40	0,284	RNHX 1204	₺1.347
T662	D063 d22 Z06 RNHX 12	63	22	6	50	0,637	PLBT	₺1.629
T664	D100 d32 Z08 RNHX 12	100	32	8	50	1,570		₺2.184
		 TC074 M4x10		 T15				

PLBT Ucuna Uygunur.

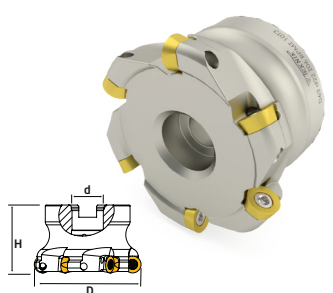
RPMW 10T3



Sipariş Kodu	Ürün Kodu	Ölçüler (mm)					Uç	Fiyat
		D	d	Z	H	kg		
T706	D040 d16 Z05 RPMW 10	40	16	5	40	0,240		₺1.152
T707	D050 d22 Z06 RPMW 10	50	22	6	40	0,359	RPMW 10T3	₺1.347
T708	D063 d22 Z06 RPMW 10	63	22	6	40	0,584	KRLY	₺1.347
T709	D080 d27 Z07 RPMW 10	80	27	7	50	1,272		₺1.548
		 TC067 M3,5x8,5		 T15				

KRLY Ucuna Uygunur.

RPMW 1204

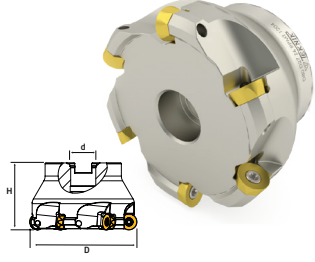

Sipariş Kodu	Ürün Kodu	Ölçüler (mm)					Uç	Fiyat
		D	d	Z	H	Hg		
T711	D050 d22 Z05 RPMW 12	50	22	5	40	0,327		₺1.152
T712	D063 d22 Z05 RPMW 12	63	22	5	40	0,556	RPMW 1204	₺1.152
T713	D080 d27 Z06 RPMW 12	80	27	6	50	0,584	KRLY	₺1.347
T714	D100 d32 Z07 RPMW 12	100	32	7	53	1,278		₺1.609
		TC073 M4x8,5	T15	2,027				

KRLY Ucuna Uygundur.

RPMW 1606

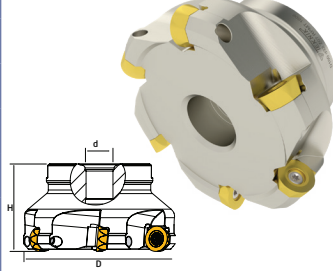

Sipariş Kodu	Ürün Kodu	Ölçüler (mm)					Uç	Fiyat
		D	d	Z	H	Hg		
T717	D063 d22 Z05 RPMW 16	63	22	5	40	0,509		₺1.152
T718	D080 d27 Z06 RPMW 16	80	27	6	50	1,048	RPMW 1606	₺1.347
T719	D100 d32 Z07 RPMW 16	100	32	7	55	0,584	KRLY	₺1.609
T720	D125 d40 Z08 RPMW 16	125	40	8	63	1,903		₺1.853
		TC083 M5x12	T20	3,775				

KRLY Ucuna Uygundur.

RDMT 1003

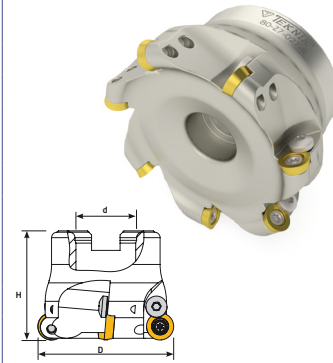

Sipariş Kodu	Ürün Kodu	Ölçüler (mm)					Uç	Fiyat
		D	d	Z	H	Hg		
T288	D040 d16 Z03 RDMT 10	40	16	3	40	0,208		₺714
T289	D040 d16 Z04 RDMT 10	40	16	4	40	0,220		₺914
T290	D050 d22 Z04 RDMT 10	50	22	4	40	0,310		₺914
T291	D050 d22 Z05 RDMT 10	50	22	5	40	0,302	RDMT 1003	₺1.152
T292	D063 d22 Z05 RDMT 10	63	22	5	40	0,445	ISO	₺1.152
T293	D063 d22 Z06 RDMT 10	63	22	6	40	0,460		₺1.347
T294	D080 d27 Z06 RDMT 10	80	27	6	50	1,033		₺1.347
T294-1	D080 d27 Z07 RDMT 10	80	27	7	50	1,048		₺1.547
T295	D100 d32 Z07 RDMT 10	100	32	7	50	1,463		₺1.607
T295-1	D100 d32 Z08 RDMT 10	100	32	8	50	1,478		₺1.825
		TC040 M3,5	TC040 M3,5	T15				

RDMT 12T3

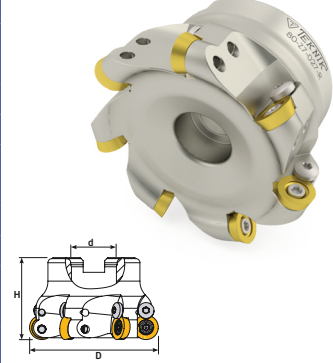

Sipariş Kodu	Ürün Kodu	Ölçüler (mm)					Uç	Fiyat
		D	d	Z	H	Hg		
T280	D040 d16 Z03 RDMT 12	40	16	3	40	0,235		₺714
T281	D040 d16 Z04 RDMT 12	40	16	4	40	0,236		₺914
T282	D050 d22 Z04 RDMT 12	50	22	4	40	0,311		₺914
T283	D050 d22 Z05 RDMT 12	50	22	5	40	0,309	RDMT 12T3	₺1.152
T284	D063 d22 Z05 RDMT 12	63	22	5	40	0,468	ISO	₺1.152
T285	D063 d22 Z06 RDMT 12	63	22	6	40	0,500		₺1.347
T286	D080 d27 Z06 RDMT 12	80	27	6	50	0,925		₺1.347
T286-1	D080 d27 Z07 RDMT 12	80	27	7	50	0,950		₺1.547
T287	D100 d32 Z07 RDMT 12	100	32	7	50	1,402		₺1.607
T287-1	D100 d32 Z08 RDMT 12	100	32	8	50	1,435		₺1.825
		TC067 M3,5x8,5	TC040 M3,5	T15				



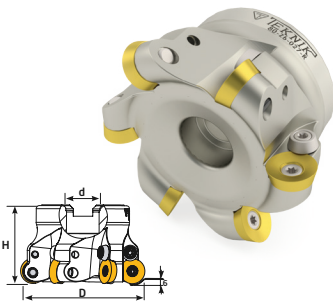

RDMT 1604

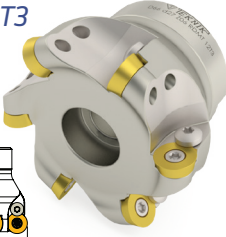
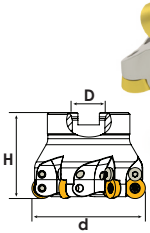

Sipariş Kodu	Ürün Kodu	Ölçüler (mm)					Uç	Fiyat
		D	d	Z	H	Hg		
T270	D050 d22 Z04 RDMT 16	50	22	4	50	0,350		₺914
T271	D052 d22 Z04 RDMT 16	52	22	4	50	0,350	RDMT 1604	₺914
T273	D063 d22 Z05 RDMT 16	63	22	5	45	0,512	ISO	₺1.152
T272	D066 d27 Z05 RDMT 16	66	27	5	50	0,495		₺1.152
T274	D080 d27 Z06 RDMT 16	80	27	6	50	0,890		₺1.347
T275	D100 d32 Z07 RDMT 16	100	32	7	52	1,370		₺1.629
		TC074 M4x10	BK035	TC080 M4,5x11	T15			

RDMT 12T3



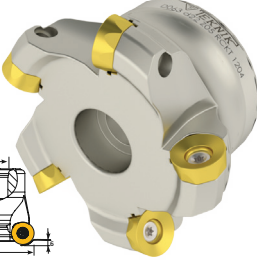
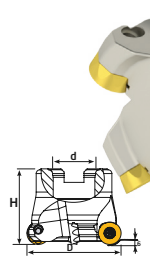

Sipariş Kodu	Ürün Kodu	Ölçüler (mm)					Uç	Fiyat
		D	d	Z	H	kg		
T667	D052 d22 Z05 RDMT 12	52	22	5	50	0,403	RDMT 12T3	₺1.152
T668-1	D066 d27 Z06 RDMT 12	66	27	6	50	0,670	PLBT	₺1.347
T668	D080 d27 Z07 RDMT 12	80	27	7	50	1,181		₺1.547

PLBT Ucuna Uygundur.

RCKT 1204



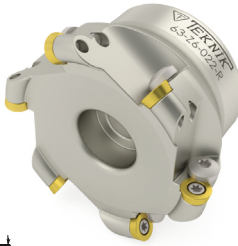
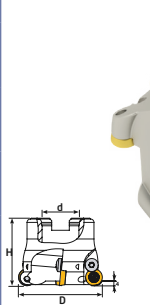

Sipariş Kodu	Ürün Kodu	Ölçüler (mm)					Uç	Fiyat
		D	d	Z	H	kg		
T460	D050 d22 Z04 RCKT 12	50	22	4	40	0,287		₺914
T462	D063 d22 Z05 RCKT 12	63	22	5	40	0,436	RCKT 1204	₺1.152
T464	D080 d27 Z06 RCKT 12	80	27	6	50	1,088	SNDVK	₺1.347
T466	D100 d32 Z07 RCKT 12	100	32	7	52	1,608		₺1.629

SNDVK Ucuna Uygundur.

RHKW 0802



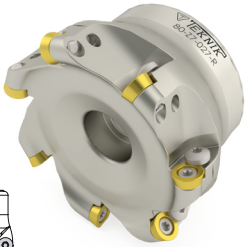
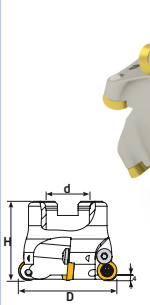

Sipariş Kodu	Ürün Kodu	Ölçüler (mm)					Uç	Fiyat
		D	d	Z	H	kg		
T599	D040 d16 Z04 RHKW 08	40	16	4	40	0,247	RHKW 0802	₺914
T600	D050 d22 Z05 RHKW 08	50	22	5	40	0,309	INGRSLL	₺1.152
T601	D063 d22 Z06 RHKW 08	63	22	6	40	0,530		₺1.347

INGRSLL Ucuna Uygundur.

RHKW 1003



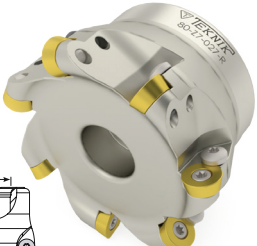
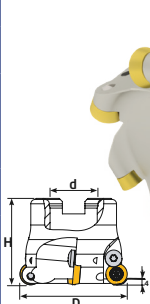

Sipariş Kodu	Ürün Kodu	Ölçüler (mm)					Uç	Fiyat
		D	d	Z	H	kg		
T602	D040 d16 Z04 RHKW 10	40	16	4	40	0,243	RHKW 1003	₺914
T604	D050 d22 Z05 RHKW 10	50	22	5	40	0,289	INGRSLL	₺1.152
T606	D063 d22 Z06 RHKW 10	63	22	6	40	0,488		₺1.347
T608	D080 d27 Z07 RHKW 10	80	27	7	50	1,080		₺1.547

INGRSLL Ucuna Uygundur.

RHKW 1204

Sipariş Kodu	Ürün Kodu	Ölçüler (mm)					Uç	Fiyat
		D	d	Z	H	kg		
T612	D040 d16 Z04 RHKW 12	40	16	4	40	0,246	RHKW 1204	₺914
T613	D050 d22 Z05 RHKW 12	50	22	5	40	0,304	INGRSLL	₺1.152
T614	D063 d22 Z06 RHKW 12	63	22	6	40	0,556		₺1.347
T615	D080 d27 Z07 RHKW 12	80	27	7	50	1,039		₺1.547

INGRSLL Ucuna Uygundur.

90° APMT 0602	Sipariş Kodu	Ürün Kodu	Ölçüler (mm)					Uç	Fiyat
			D	d	Z	H	kg		
	T596	D40 d16 Z10 APMT 06	40	16	10	40	0,281	APMT 0602	₺2.438
	T597	D50 d22 Z12 APMT 06	50	22	12	40	0,435	KRLY	₺2.925
	T598	D63 d22 Z14 APMT 06	63	22	14	40	0,715		₺3.218

KRLY Ucuna Uygundur.

90° APMT 11T3	Sipariş Kodu	Ürün Kodu	Ölçüler (mm)					Uç	Fiyat
			D	d	Z	H	kg		
	T250	D040 d16 Z05 APMT 11	40	16	5	40	0,220		₺1.152
	T252	D050 d22 Z06 APMT 11	50	22	6	40	0,332	APMT 11T3	₺1.347
	T254	D063 d22 Z07 APMT 11	63	22	7	40	0,483	KRLY	₺1.547
	T256	D080 d27 Z08 APMT 11	80	27	8	50	1,115		₺1.785
	T258	D100 d32 Z10 APMT 11	100	32	10	63	1,810		₺2.183

KRLY Ucuna Uygundur.

90° APMT 1604	Sipariş Kodu	Ürün Kodu	Ölçüler (mm)					Uç	Fiyat
			D	d	Z	H	kg		
	T241	D040 d16 Z04 APMT 16	40	16	4	45	0,258		₺914
	T243	D050 d22 Z05 APMT 16	50	22	5	45	0,400	APMT 1604	₺1.152
	T245	D063 d22 Z06 APMT 16	63	22	6	45	0,578	KRLY	₺1.347
	T247	D080 d27 Z07 APMT 16	80	27	7	52	1,249		₺1.547
	T249	D100 d32 Z08 APMT 16	100	32	8	52	1,530		₺1.825

KRLY Ucuna Uygundur.

90° APKT 1604	Sipariş Kodu	Ürün Kodu	Ölçüler (mm)					Uç	Fiyat
			D	d	Z	H	kg		
	T767	D050 d22 Z04 APKT 16	50	22	4	45	0,381	APKT 1604	₺914
	T768	D063 d22 Z05 APKT 16	63	22	5	45	0,507	YG1	₺1.152
	T769	D080 d27 Z06 APKT 16	80	27	6	52	1,125		₺1.347

YG1 ucuna uygundur.



90° APKT 1604	Sipariş Kodu	Ürün Kodu	Ölçüler (mm)					Uç	Fiyat
			D	d	Z	H	kg		
	T180	D040 d16 Z03 APKT 16	40	16	3	45	0,267		₺714
	T181	D040 d16 Z04 APKT 16	40	16	4	45	0,258		₺914
	T182	D050 d22 Z04 APKT 16	50	22	4	45	0,406		₺914
	T183	D050 d22 Z05 APKT 16	50	22	5	45	0,400		₺1.152
	T184	D063 d22 Z05 APKT 16	63	22	5	45	0,577		₺1.152
	T185	D063 d22 Z06 APKT 16	63	22	6	45	0,578	APKT 1604	₺1.347
	T186	D080 d27 Z06 APKT 16	80	27	6	52	1,159	KRLY	₺1.347
	T187	D080 d27 Z07 APKT 16	80	27	7	52	1,249		₺1.547
	T188	D100 d32 Z07 APKT 16	100	32	7	52	1,057		₺1.586
	T189	D100 d32 Z08 APKT 16	100	32	8	52	1,530		₺1.825
	T190	D125 d40 Z09 APKT 16	125	40	9	62	3,642		₺2.301
	T192	D160 d40 Z10 APKT 16	160	40	10	62	4,885		₺2.917
	T193	D200 d60 Z12 APKT 16	200	60	12	63	6,370		₺4.167
	T195	D300 d60 Z15 APKT 16	300	60	15	62	14,360		₺7.376

KRLY Ucuna Uygundur.

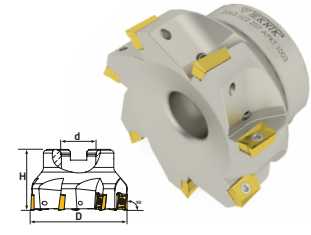
90° APXT 1003



Sipariş Kodu	Ürün Kodu	Ölçüler (mm)					Uç	Fiyat
		D	d	Z	H	kg		
T176	D040 d16 Z05 APXT 10	40	16	5	40	0,277		₺1.152
T177	D050 d22 Z06 APXT 10	50	22	6	40	0,398	APXT 1003	₺1.347
T178	D063 d22 Z07 APXT 10	63	22	7	40	0,543	KRLY	₺1.547
T179	D080 d27 Z08 APXT 10	80	27	8	50	1,205		₺1.785



 TC060 M2,5x5,5
  T8
 

KRLY Ucuna Uygunur.

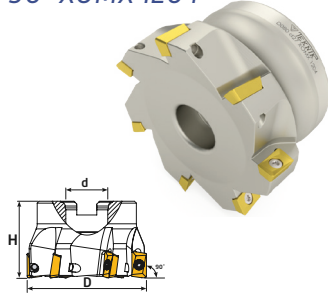
90° XOMX 1204



Sipariş Kodu	Ürün Kodu	Ölçüler (mm)					Uç	Fiyat
		D	d	Z	H	kg		
T510	D040 d16 Z04 XOMX 12	40	16	4	40	0,250		₺914
T512	D050 d22 Z05 XOMX 12	50	22	5	40	0,351		₺1.152
T514	D063 d22 Z06 XOMX 12	63	22	6	40	0,618	XOMX 1204	₺1.347
T516	D080 d27 Z07 XOMX 12	80	27	7	50	1,155	SCO	₺1.547
T518	D100 d32 Z10 XOMX 12	100	32	10	52	1,817		₺2.183
T519	D125 d40 Z12 XOMX 12	125	40	12	62	3,565		₺2.698



 TC069 M3,5x8,5
  T10
 

SCO Ucuna Uygunur.

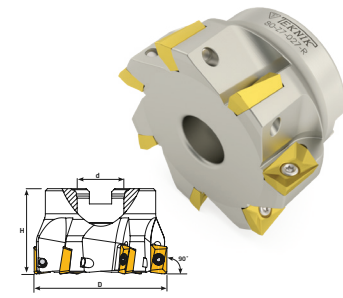
90° XOMX 1806



Sipariş Kodu	Ürün Kodu	Ölçüler (mm)					Uç	Fiyat
		D	d	Z	H	kg		
T520	D050 d22 Z05 XOMX 18	50	22	5	45	0,337		₺1.152
T522	D063 d22 Z06 XOMX 18	63	22	6	45	0,550		₺1.347
T524	D080 d27 Z07 XOMX 18	80	27	7	50	1,082	XOMX 1806	₺1.547
T525	D100 d32 Z08 XOMX 18	100	32	8	52	1,661	SCO	₺1.825
T526	D125 d40 Z09 XOMX 18	125	40	9	62	3,427		₺2.301
T527	D160 d40 Z10 XOMX 18	160	40	10	62	4,831		₺2.917



 TC080 M4,5x11
  T15
 

SCO Ucuna Uygunur.

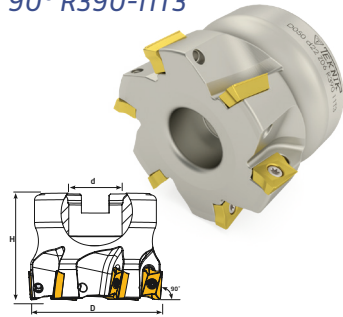
90° R390-11T3



Sipariş Kodu	Ürün Kodu	Ölçüler (mm)					Uç	Fiyat
		D	d	Z	H	kg		
T577	D040 d16 Z05 R390 11	40	16	5	40	0,225	R390-11T3	₺1.152
T578	D050 d22 Z06 R390 11	50	22	6	40	0,355	SNDVK	₺1.347
T579	D063 d22 Z07 R390 11	63	22	7	40	0,503		₺1.547



 TC063 M2,5x7
  T8
 

SNDVK Ucuna Uygunur.

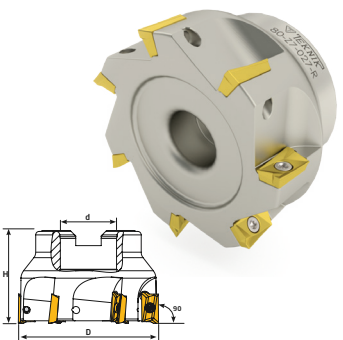
90° R390-1704



Sipariş Kodu	Ürün Kodu	Ölçüler (mm)					Uç	Fiyat
		D	d	Z	H	kg		
T402	D040 d16 Z04 R390 17	40	16	4	45	0,276		₺914
T404	D050 d22 Z05 R390 17	50	22	5	45	0,591		₺1.152
T408	D063 d22 Z06 R390 17	63	22	6	45	0,590	R390-1704	₺1.347
T411	D080 d27 Z07 R390 17	80	27	7	52	1,168	SNDVK	₺1.547
T412	D100 d32 Z08 R390 17	100	32	8	52	1,665		₺1.825
T414	D125 d40 Z09 R390 17	125	40	9	62	3,680		₺2.301
T416	D160 d40 Z10 R390 17	160	40	10	62	5,010		₺2.917

 TC069 M3,5x8,5
  T15
 

SNDVK Ucuna Uygunur.

90° R390-1806

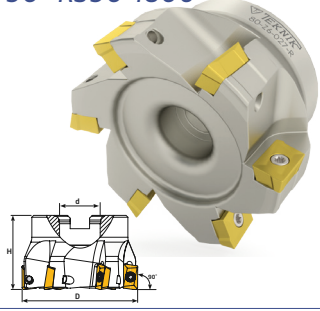

SNDVK Ucuna Uygundur.

Sipariş Kodu	Ürün Kodu	Ölçüler (mm)					Uç	Fiyat
		D	d	Z	H	kg		
T423	D050 d22 Z04 R390 18	50	22	4	45	0,303		₺914
T424	D063 d22 Z05 R390 18	63	22	5	45	0,490	R390-1806	₺1.152
T426	D080 d27 Z06 R390 18	80	27	6	52	1,081	SNDVK	₺1.347
T428	D100 d32 Z07 R390 18	100	32	7	52	1,595		₺1.629
T430	D125 d40 Z08 R390 18	125	40	8	62	3,558		₺2.046
T432	D160 d40 Z10 R390 18	160	40	10	62	4,411		₺2.917
		TC074 M4x10		T15				

90° ADMT 1204

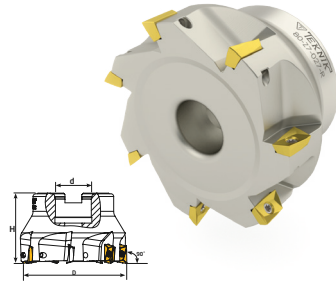

WLTR Ucuna Uygundur.

Sipariş Kodu	Ürün Kodu	Ölçüler (mm)					Uç	Fiyat
		D	d	Z	H	kg		
T214	D040 d16 Z04 ADMT 12	40	16	4	45	0,280		₺914
T215	D050 d22 Z05 ADMT 12	50	22	5	45	0,350	ADMT 1204	₺1.152
T217	D063 d22 Z06 ADMT 12	63	22	6	45	0,610	WLTR	₺1.347
T219	D080 d27 Z07 ADMT 12	80	27	7	52	1,176		₺1.547
T220	D100 d32 Z08 ADMT 12	100	32	8	52	1,595		₺1.825
		TC065 M3x7		T8				

90° ADMT 1606

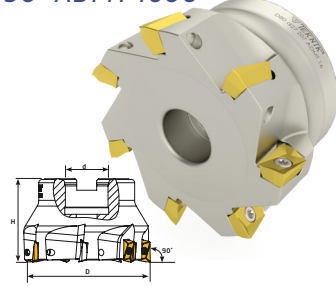

WLTR Ucuna Uygundur.

Sipariş Kodu	Ürün Kodu	Ölçüler (mm)					Uç	Fiyat
		D	d	Z	H	kg		
T351	D040 d16 Z04 ADMT 16	40	16	4	45	0,258		₺914
T352	D050 d22 Z05 ADMT 16	50	22	5	45	0,397	ADMT 1606	₺1.152
T354	D063 d22 Z06 ADMT 16	63	22	6	45	0,578	WLTR	₺1.347
T356	D080 d27 Z07 ADMT 16	80	27	7	52	1,254		₺1.547
		TC072 M4x10		T15				

90° BDMT 11T3

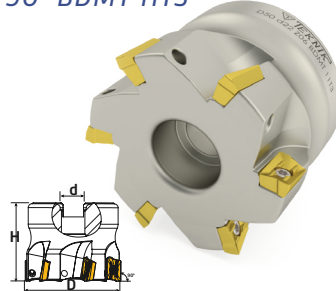

KYCRA Ucuna Uygundur.

Sipariş Kodu	Ürün Kodu	Ölçüler (mm)					Uç	Fiyat
		D	d	Z	H	kg		
T533	D040 d16 Z05 BDMT 11	40	16	5	40	0,224	BDMT 11T3	₺1.152
T534	D050 d22 Z06 BDMT 11	50	22	6	40	0,361	KYCRA	₺1.347
T535	D063 d22 Z07 BDMT 11	63	22	7	40	0,527		₺1.547
		TC060 M2,5x5,5		T8				

90° BDMT 1704

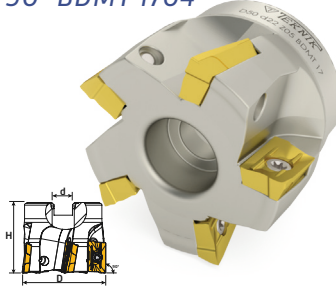

KYCRA Ucuna Uygundur.

Sipariş Kodu	Ürün Kodu	Ölçüler (mm)					Uç	Fiyat
		D	d	Z	H	kg		
T537	D040 d16 Z04 BDMT 17	40	16	4	40	0,190		₺914
T538	D050 d22 Z05 BDMT 17	50	22	5	40	0,312	BDMT 1704	₺1.152
T539	D063 d22 Z06 BDMT 17	63	22	6	40	0,516	KYCRA	₺1.347
T540	D080 d27 Z07 BDMT 17	80	27	7	50	1,165		₺1.547
		TC074 M4x10		T15				

90° APKT 1705

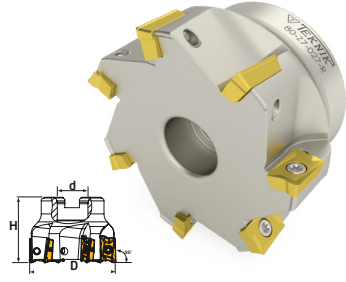

Sipariş Kodu	Ürün Kodu	Ölçüler (mm)					Uç	Fiyat
		D	d	Z	H	kg		
T550	D040 d16 Z04 APKT 17	40	16	4	45	0,239		₺914
T552	D050 d22 Z05 APKT 17	50	22	5	45	0,362	APKT 1705	₺1.152
T554	D063 d22 Z06 APKT 17	63	22	6	45	0,520	TGTC	₺1.347
T556	D080 d27 Z07 APKT 17	80	27	7	50	1,047		₺1.547
T558	D100 d32 Z08 APKT 17	100	32	8	52	1,620		₺1.825
		TC074 M4x10		T15				

TGTC Ucuna Uygundur.

90° ADKT 1505

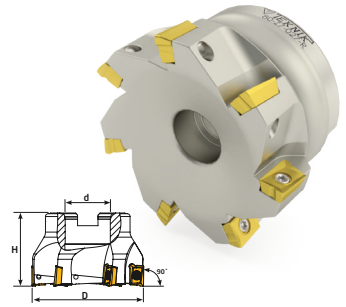

Sipariş Kodu	Ürün Kodu	Ölçüler (mm)					Uç	Fiyat
		D	d	Z	H	kg		
T200	D040 d16 Z04 ADKT 15	40	16	4	45	0,270		₺914
T202	D050 d22 Z05 ADKT 15	50	22	5	45	0,394	ADKT 1505	₺1.152
T204	D063 d22 Z06 ADKT 15	63	22	6	45	0,565	ISCR	₺1.347
T206	D080 d27 Z07 ADKT 15	80	27	7	52	1,152		₺1.547
T207	D100 d32 Z08 ADKT 15	100	32	8	52	1,546		₺1.825
T208	D125 d40 Z09 ADKT 15	125	40	9	62	0,272		₺2.301
		TC074 M4x10		T15				

ISCR Ucuna Uygundur.

90° BOMT 1304

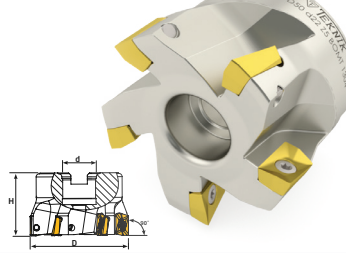

Sipariş Kodu	Ürün Kodu	Ölçüler (mm)					Uç	Fiyat
		D	d	Z	H	kg		
T965	D040 d16 Z04 BOMT 13	40	16	4	40	0,272	BOMT 1304	₺914
T966	D050 d22 Z05 BOMT 13	50	22	5	40	0,369	INGRSLL	₺1.152
T967	D063 d22 Z06 BOMT 13	63	22	6	40	0,613		₺1.347
		TC069 M3,5x8,5		T10				

INGRSLL Ucuna Uygundur.

APKT 16 Havşa

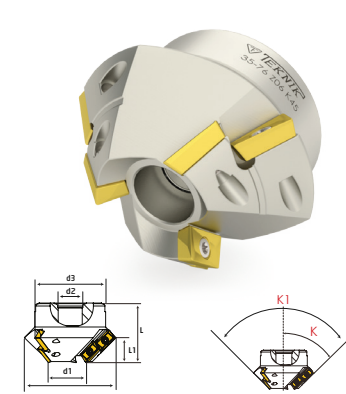

Sipariş Kodu	Ürün Kodu	Ölçüler (mm)										Uç	Fiyat
		K	K1	d1	D	Z	d2	d3	L	L1	kg		
T457	35-50,5 Z06 K15° APKT 16	15°	30°	35	50,5	6	22	45	60	30	0,415		₺1.785
T454	35-65 Z06 K30° APKT 16	30°	60°	35	65	6	27	48	50	26,3	0,610	APKT 1604	₺1.785
T456	35-76 Z06 K45° APKT 16	45°	90°	35	76	6	27	60	50	21,5	0,734	KRLY	₺1.785
T455	35-86 Z06 K60° APKT 16	60°	120°	35	86	6	27	60	50	15	0,892		₺1.785
T458	35-94 Z06 K75° APKT 16	75°	150°	35	94	6	27	60	50	8,5	1,256		₺1.785
		TC074 M4x10		T15									

KRLY Ucuna Uygundur.

F 75° APKT 1604 - APXT 1003

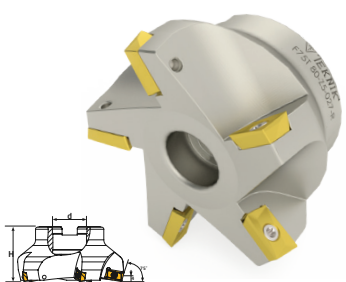

Sipariş Kodu	Ürün Kodu	Ölçüler (mm)					Uç	Fiyat
		D	d	Z	H	kg		
T308	D063 d22 Z04 APKT 16	63	22	4	45	0,510		₺1.014
T310	D080 d27 Z05 APKT 16	80	27	5	52	1,120	APKT 1604	₺1.269
T312	D100 d32 Z06 APKT 16	100	32	6	52	1,587	KRLY	₺1.469
T313	D125 d40 Z07 APKT 16	125	40	7	62	3,047		₺2.025
T452	D063 d22 Z06 APXT 10	63	22	6	45	0,630	APXT 1003 KRLY	₺1.629
		T308-T313 T452		T308-T313 T452				
		TC074 M4x10 TC074 M4x10		T15 T8				

KRLY Ucuna Uygundur.

90° VCGT 1604

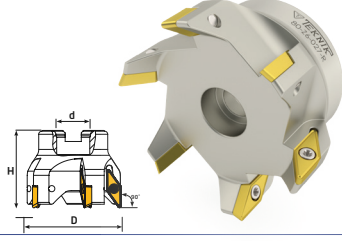

Sipariş Kodu	Ürün Kodu	Ölçüler (mm)					Uç	Fiyat
		D	d	Z	H			
T498	D040 d16 Z03 VCGT 16	40	16	3	52	0,277		₺714
T500	D050 d22 Z04 VCGT 16	50	22	4	52	0,362	VCGT 1604	₺914
T502	D063 d22 Z05 VCGT 16	63	22	5	52	0,538	ISO	₺1.152
T504	D080 d27 Z06 VCGT 16	80	27	6	52	0,848		₺1.347
			TC074 M4x10			T15		

F 75° ADKT 1505

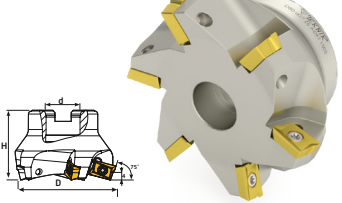

Sipariş Kodu	Ürün Kodu	Ölçüler (mm)					Uç	Fiyat
		D	d	Z	H			
T530	D063 d22 Z05 ADKT 15	63	22	5	45	0,580	ADKT 1505	₺1.152
T532	D080 d27 Z06 ADKT 15	80	27	6	50	1,090	ISCR	₺1.347
			TC074 M4x10			T15		

ISCR Ucuna Uygundur.

TPKN 1603-2204

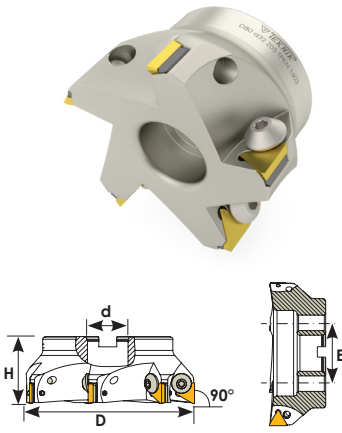

Sipariş Kodu	Ürün Kodu	Ölçüler (mm)						Uç	Fiyat
		D	d	Z	H	E			
T100	D080 d32 Z05 TPKN 16 A	80	32	5	52	--	0,961	TPKN 1603	₺1.665
T102	D100 d32 Z06 TPKN 16 A	100	32	6	52	--	1,518	ISO	₺1.924
T104	D080 d32 Z04 TPKN 22 A	80	32	4	52	--	0,810		₺1.785
T106	D100 d32 Z05 TPKN 22 A	100	32	5	52	--	1,444	TPKN 2204	₺2.064
T108	D125 d40 Z06 TPKN 22 A	125	40	6	62	--	3,164	ISO	₺2.617
T110	D160 d40 Z07 TPKN 22 A	160	40	7	62	66,7	4,220		₺3.294
T112	D200 d60 Z08 TPKN 22 A	200	60	8	62	101,6	5,412		₺4.284
T113	D250 d60 Z09 TPKN 22 A	250	60	9	62	101,6	8,166		₺4.840
Kod			TC052 M6x17			4 Allen			
T100-T102			TC054 M8x24			5 Allen			
T104-T113									

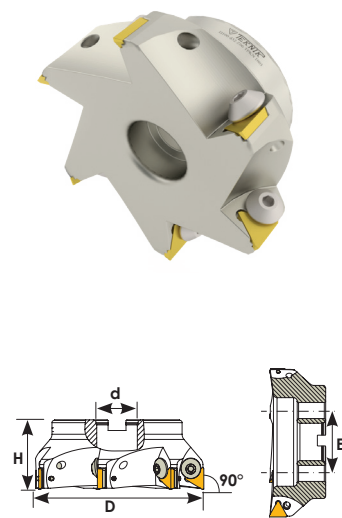

TPKN 1603-2204



Sipariş Kodu	Ürün Kodu	Ölçüler (mm)						Uç	Fiyat
		D	d	Z	H	E			
T114	D042 d16 Z03 TPKN 16	42	16	3	44	--	0,280		₺714
T116	D050 d22 Z03 TPKN 16	50	22	3	44	--	0,340	TPKN 1603	₺736
T118	D063 d22 Z03 TPKN 16	63	22	3	44	--	0,463	ISO	₺814
T120	D063 d22 Z04 TPKN 16	63	22	4	44	--	0,481		₺950
T122	D080 d32 Z05 TPKN 16	80	32	5	52	--	0,954		₺1.232
T124	D100 d32 Z06 TPKN 16	100	32	6	52	--	1,542		₺1.469
T126	D063 d22 Z03 TPKN 22	63	22	3	50	--	0,532		₺814
T128	D080 d32 Z04 TPKN 22	80	32	4	52	--	0,795	TPKN 2204	₺1.269
T130	D100 d32 Z05 TPKN 22	100	32	5	52	--	1,398	ISO	₺1.469
T132	D125 d40 Z06 TPKN 22	125	40	6	62	--	3,153		₺1.944
T134	D160 d40 Z07 TPKN 22	160	40	7	62	66,7	4,150		₺2.262
T136	D200 d60 Z08 TPKN 22	200	60	8	62	101,6	5,458		₺3.251
T138	D250 d60 Z09 TPKN 22	250	60	9	62	101,6	8,235		₺4.362
Kod			TC052 M6x17			4 Allen			
T114-T124			TC054 M8x24			5 Allen			
T126-T138									

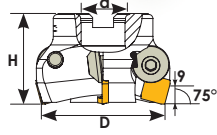
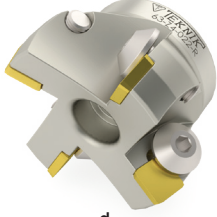



SPKN 1203

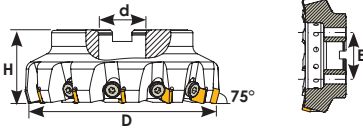

Sipariş Kodu	Ürün Kodu	Ölçüler (mm)				Uç	Fiyat
		ØD	ød	Z	H		
T148	D050 d22 Z03 SPKN 12	50	22	3	45	SPKN 1203	₺735
T150	D063 d22 Z04 SPKN 12	63	22	4	45	ISO	₺914
Code		 TC054 M8x24		 5 Allen			

SPKN 1203



Sipariş Kodu	Ürün Kodu	Ölçüler (mm)						Uç	Fiyat
		D	d	Z	H	E			
T152	D080 d27 Z06 SPKN 12	80	27	6	55	---	1,260		₺1.347
T154	D100 d32 Z08 SPKN 12	100	32	8	55	---	1,698	SPKN 1203	₺1.825
T156	D125 d40 Z10 SPKN 12	125	40	10	62	---	3,400	ISO	₺2.698
T158	D160 d40 Z12 SPKN 12	160	40	12	62	66,7	5,012		₺3.156
T160	D200 d60 Z12 SPKN 12	200	60	12	62	101,6	6,542		₺4.167
T162	D300 d60 Z20 SPKN 12	300	60	20	65	101,6	15,11		₺7.735
Kod		 TC056 Sol M8x24-L		 5 Allen					



www.teknikcuttingtools.com



THB 01 SET 9-130 mm

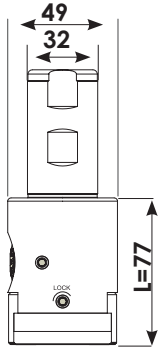
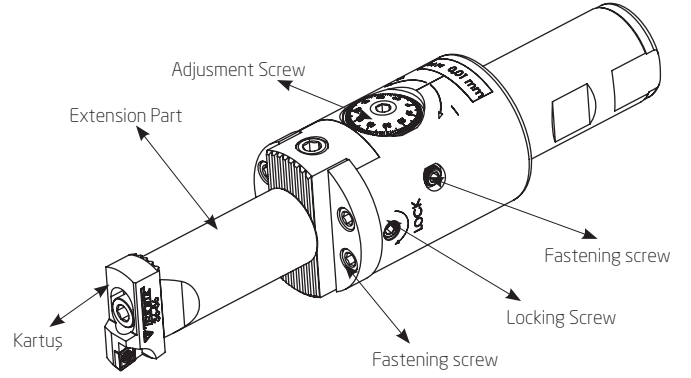
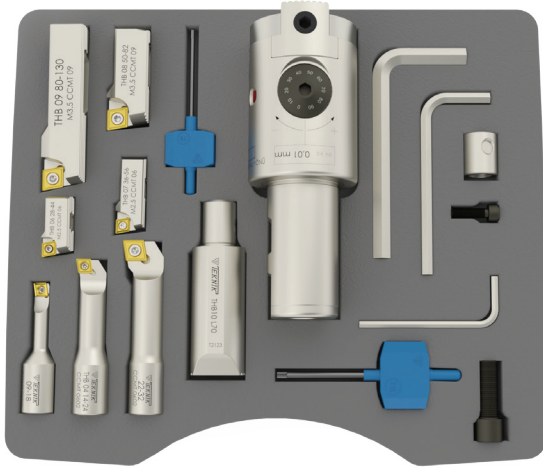

THB 02
GÖVDE
BODY
Fine / Fein

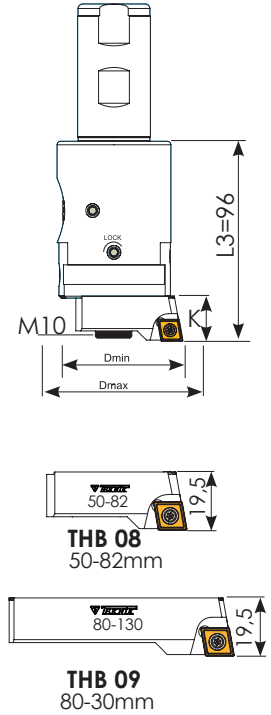
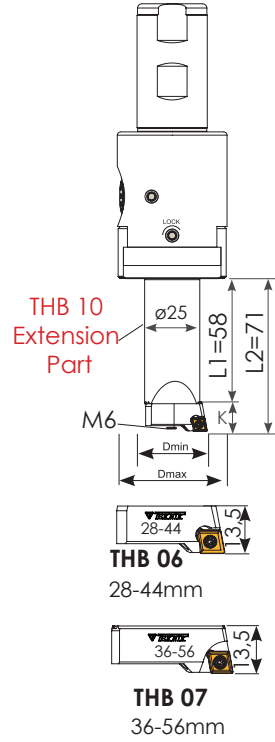
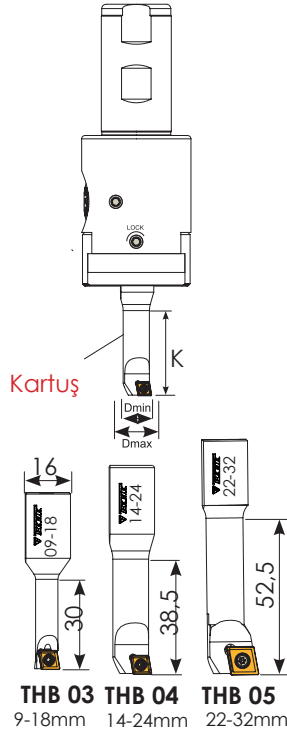
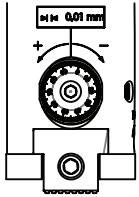

Sipariş Kodu	Ürün Kodu	K	L1	L2	L3	Dmin - Dmax	kg		Fiyat
THB01	Hassas Bara SETİ / SET	9-130	3,100	...	₺12.098
THB02	GÖVDE / BODY	-	...	₺6.068
THB03	09-18 Kartuş	32,5	9-18	-	CCMT 0602	₺491
THB04	14-24 Kartuş	39,6	14-24	-	CCMT 0602	₺636
THB05	22-32 Kartuş	52,5	22-32	-	CCMT 09T3	₺775
THB06	28-44 Kartuş	13,7	...	71	...	28-44	-	CCMT 0602	₺775
THB07	36-56 Kartuş	13,7	...	71	...	36-56	-	CCMT 0602	₺775
THB08	50-82 Kartuş	19,5	95,5	50-82	-	CCMT 09T3	₺892
THB09	80-130 Kartuş	19,5	95,5	80-130	-	CCMT 09T3	₺950
THB10	ARA UZATMA	...	58	-	...	₺597

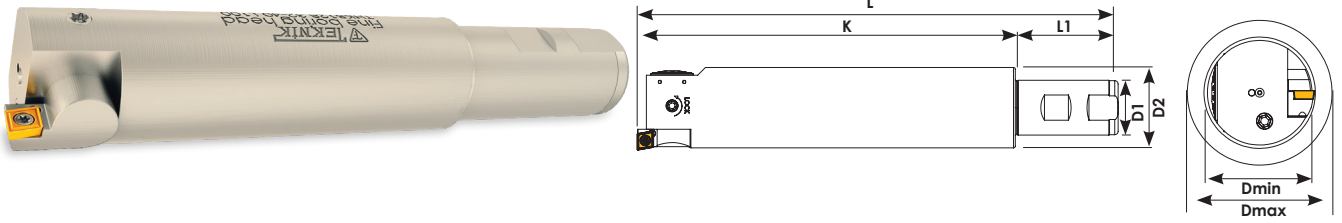

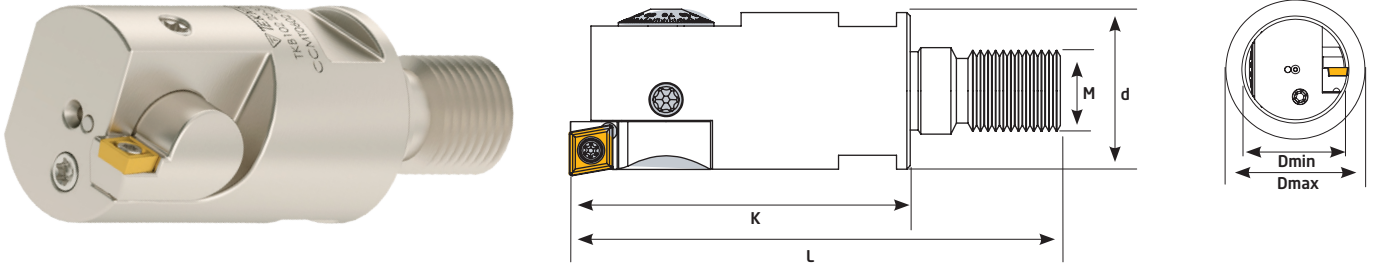

Sipariş Kodu	Ürün Kodu	Ölçüler (mm)								Uç	Hassasiyet → ← (mm)	Fiyat
		Dmin	Dmax	K	D1	L1	D2	L	kg			
THKB120	25-32 K050 CCMT 06	25	32	50	25	56	23	106	0,402	CCMT 0602	0,02	₺4.958
THKB122	25-32 K100 CCMT 06	25	32	100	25	56	23	156	0,570	ISO.		₺5.513
THKB126	32-40 K060 CCMT 06	32	40	60	25	56	29	116	0,510		0,01	₺5.513
THKB128	32-40 K104 CCMT 06	32	40	104	25	56	29	160	0,760			₺5.630
THKB132	40-50 K069 CCMT 06	40	50	69	25	56	36	125	0,722	CCMT 0602	₺5.630	
THKB134	40-50 K109 CCMT 06	40	50	109	25	56	36	165	1,085		₺5.831	
THKB136	40-50 K189 CCMT 06	40	50	189	25	56	36	245	1,723		₺6.107	
THKB138	50-65 K065 CCMT 09	50	65	65	32	60	47	125	1,231		0,01	₺5.753
THKB140	50-65 K130 CCMT 09	50	65	130	32	60	47	190	2,135	CCMT 09T3		₺5.912
THKB142	50-65 K220 CCMT 09	50	65	220	32	60	47	280	3,383	ISO.	₺6.266	
THKB144	65-80 K085 CCMT 09	65	80	85	32	60	60	145	1,900		₺5.753	
THKB146	65-80 K130 CCMT 09	65	80	130	32	60	60	190	2,547		₺6.107	
THKB148	65-80 K220 CCMT 09	65	80	220	32	60	60	280	3,895		₺6.466	

25-40 mm Hassas Bara

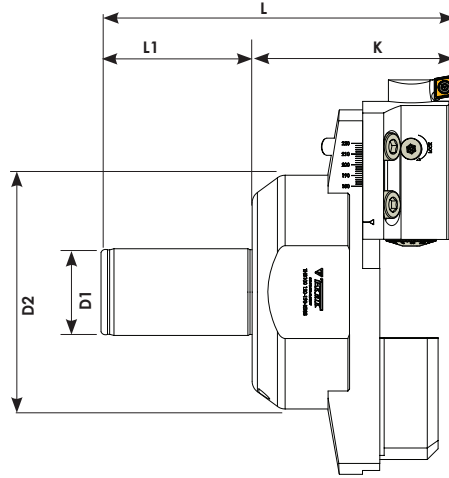
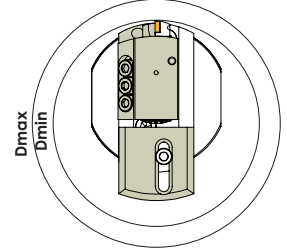
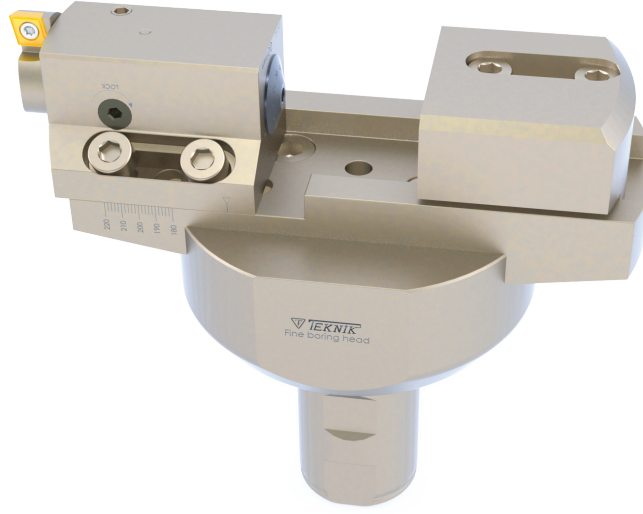

Order Kod	Ürün Kodu	Ölçüler (mm)							Hassasiyet → ← (mm)	Uç	Fiyat
		Dmin	Dmax	M	K	L	d	kg			
THKB102	25-32 K050 M12 CCMT 06	25	32	M12	50	72	23	0,194	0,02	CCMT 0602 ISO.	₺3.926
THKB104	32-40 K050 M16 CCMT 06	32	40	M16	50	74,3	29	0,287	0,01	CCMT 0602 ISO.	₺4.125



Sipariş Kodu	Ürün Kodu	Ölçüler (mm)								Uç	Fiyat
		Dmin	Dmax	K	D1	L1	D2	L			
THB100	120-190 K093 CCMT 09	120	190	93,7	40	70	109	163,7	5,060	CCMT 09T3	₺6.149
THB101	180-240 K093 CCMT 09	180	240	93,7	40	70	109	163,7	5,967	ISO.	₺7.496
THB102	240-300 K093 CCMT 09	240	300	93,7	40	70	109	163,7	7,000		₺9.004

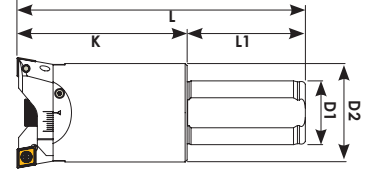
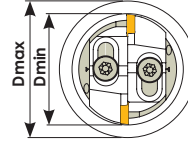

Sipariş Kodu	Ürün Kodu	Ölçüler (mm)								Uç	Fiyat
		Dmin	Dmax	K	D1	L1	D2	L			
TKB088	16-20 K052 WCMX 03	16	20	52	16	48	15,7	100	0,176	WCMX 0302	₺2.220
TKB090	16-20 K102 WCMX 03	16	20	102	16	48	15,7	150	0,237	ISO.	₺2.301
TKB092	16-20 K152 WCMX 03	16	20	152	16	48	15,7	200	0,362		₺2.898
TKB094	19-23 K052 CCMT 06	19	23	52	16	48	17,7	100	0,192		₺2.220
TKB096	19-23 K102 CCMT 06	19	23	102	16	48	17,7	150	0,292	CCMT 0602	₺2.301
TKB098	19-23 K152 CCMT 06	19	23	152	16	48	17,7	200	0,401	ISO.	₺2.898
TKB100	23-28 K050 CCMT 06	23	28	50	20	50	21,2	100	0,298		₺2.220
TKB102	23-28 K100 CCMT 06	23	28	100	20	50	21,2	150	0,347		₺2.301
TKB104	23-28 K185 CCMT 06	23	28	185	20	50	21,2	235	0,682		₺2.898
TKB106	28-38 K055 CCMT 09	28	38	55	20	50	25,7	105	0,378		₺2.262
TKB108	28-38 K105 CCMT 09	28	38	105	20	50	25,7	155	0,376		₺2.361
TKB110	28-38 K174 CCMT 09	28	38	174	25	56	25,7	230	0,267		₺2.976
TKB111	28-38 K274 CCMT 09	28	38	274	25	56	25,7	330	1,342		₺3.055
TKB112	37-48 K064 CCMT 09	37	48	64	25	56	32	120	0,661		₺2.341
TKB114	37-48 K114 CCMT 09	37	48	114	25	56	33	170	0,991	CCMT 0903	₺2.679
TKB116	37-48 K204 CCMT 09	37	48	204	25	56	33	260	1,597	ISO.	₺3.134
TKB118	45-56 K070 CCMT 09	45	56	70	32	60	39,5	130	1,035		₺2.361
TKB120	45-56 K120 CCMT 09	45	56	120	32	60	40	180	1,528		₺2.679
TKB122	45-56 K200 CCMT 09	45	56	200	32	60	40	260	2,385		₺3.294
TKB124	55-75 K085 CCMT 09	55	75	85	32	60	50	145	1,638		₺2.679
TKB126	55-75 K135 CCMT 09	55	75	135	32	60	50	195	2,422		₺2.757
TKB128	55-75 K220 CCMT 09	55	75	220	32	60	50	280	3,745		₺3.374
TKB130	70-90 K085 CCMT 09	70	90	85	32	60	64	145	2,100		₺2.679
TKB132	70-90 K135 CCMT 09	70	90	135	32	60	64	195	2,942		₺2.917
TKB134	70-90 K220 CCMT 09	70	90	220	40	70	64	290	4,915		₺3.374
TKB136	90-130 K115 CCMT 09	90	130	115	32	60	74	175	3,130		₺3.093
TKB138	90-130 K165 CCMT 09	90	130	165	32	60	74	225	4,138		₺3.471

Kartuş

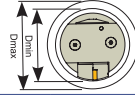
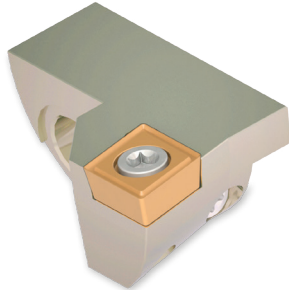

Sipariş Kodu	Dmin-Dmax	Uç	Fiyat
KR096	16-20	WCMX 0302	₺814
KR098	19-23	CCMT 0602	₺814
KR100	23-28	CCMT 0602	₺814
KR102	28-38	CCMT 09T3	₺872
KR104	37-48	CCMT 09T3	₺914
KR106	45-56	CCMT 09T3	₺950
KR108	55-75	CCMT 09T3	₺993
KR110	70-90	CCMT 09T3	₺1.014
KR112	90-130	CCMT 09T3	₺1.073
KR115	55-75	CCMT 1204	₺974
KR116	70-90	CCMT 1204	₺1.014
KR117	90-130	CCMT 1204	₺1.073

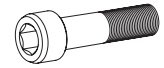

Sipariş Kodu	Sabitleme Cıvatası	Fiyat
TC102	M4x16	₺30
TC102	M4x16	₺30
TC104	M5x25	₺30
TC104	M5x25	₺30
TC106	M6x30	₺30
TC108	M8x30	₺30
TC108	M8x30	₺30
TC108	M8x30	₺30
TC108	M8x30	₺30
TC108	M8x30	₺30
TC108	M8x30	₺30
TC108	M8x30	₺30
TC108	M8x30	₺30

16-38 mm Kaba Bara

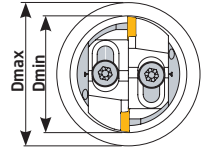
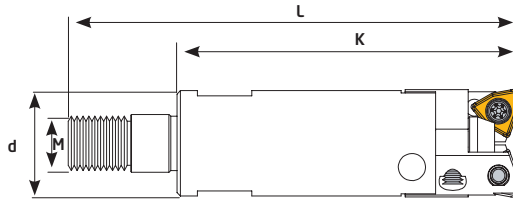

Sipariş Kodu	Ürün Kodu	Ölçüler (mm)							Uç	Fiyat
		Dmin	Dmax	M	K	L	d	kg		
TKB170	16-20 K050 M08 WCMX 03	16	20	M08	50	66	15,5	0,078	WCMX 0302 ISO.	₺2.103
TKB172	19-23 K050 M10 CCMT 06	19	23	M10	50	70	17,5	0,095	CCMT 0602 ISO.	₺2.103
TKB174	23-28 K050 M12 CCMT 06	23	28	M12	50	72	21,2	0,145	CCMT 0602 ISO.	₺2.103
TKB176	28-38 K050 M16 CCMT 09	28	38	M16	50	74,5	25,7	0,213	CCMT 09T3 ISO.	₺2.183

120-350 mm Kaba Bara

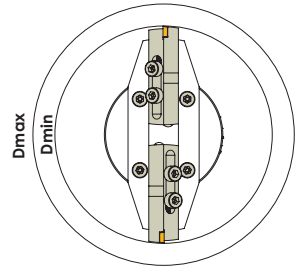
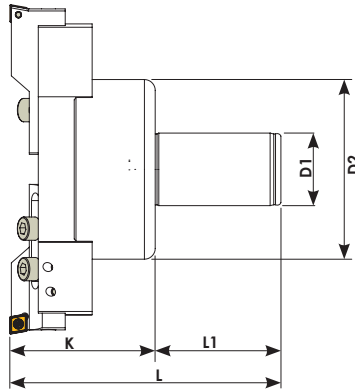

Sipariş Kodu	Ürün Kodu	Ölçüler (mm)								Uç	Fiyat
		Dmin	Dmax	K	D1	L1	D2	L	kg		
TKB148	120-170 K069 CCMT 12	120	170	69	40	70	115,5	139	3,281	CCMT 1204	₺5.117
TKB150	170-250 K084 CCMT 12	170	250	84	40	70	99,5	154	5,011	ISO.	₺7.337
TKB152	240-350 K084 CCMT 12	240	350	84	40	70	149,5	154	8,294		₺8.727

Kartuş

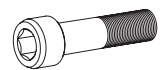
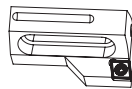
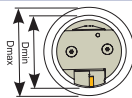
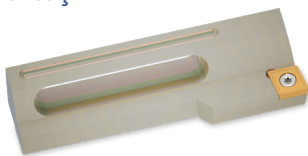

Sipariş Kodu	Dmin-Dmax	Uç	Fiyat	Sipariş Kodu	Sıkma Cıvatası	Fiyat
KR119	120-170	CC MT 1204	₺1.507	TC109	M8x25	₺30
KR120	170-250	CC MT 1204	₺1.570	TC109	M8x25	₺30
KR124	240-350	CC MT 1204	₺1.785	TC109	M8x25	₺30

Helis ve Disk Frezeler



www.teknikcuttingtools.com



Kalite için TEKNİK çözüm
Technical solution for quality



32-33

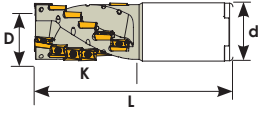
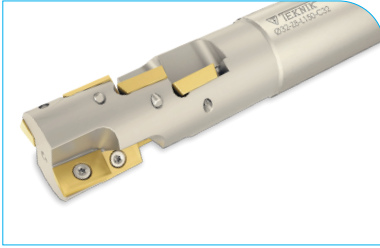

APKT 1604



Sipariş Kodu	Ürün Kodu	Ölçüler (mm)						Uç	Fiyat
		D	Z	K	d	L	kg		
HF20	D32 Z06 K43 APKT 16	32	6	43	32	125	0,658		₺3.374
HF22	D40 Z09 K43 APKT 16	40	9	43	32	125	0,821	APKT 1604	₺3.749
HF24	D32 Z08 K58 APKT 16	32	8	58	32	150	0,771	KRLY	₺3.333
HF26	D40 Z12 K58 APKT 16	40	12	58	32	150	0,950		₺4.997
HF30	D32 Z08 K58 APKT 16	32	8	58	32	200	1,120		₺3.333
HF32	D40 Z12 K58 APKT 16	40	12	58	32	200	1,280		₺4.997



 TC074 M4x10
  T15
 

KRLY ucuna uygundur.

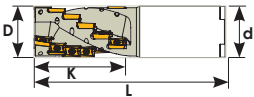
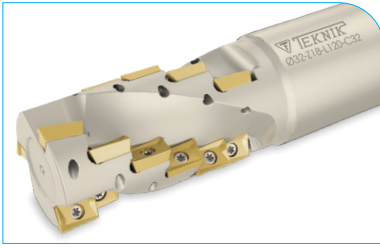
APXT 1003



Sipariş Kodu	Ürün Kodu	Ölçüler (mm)						Uç	Fiyat
		D	Z	K	d	L	kg		
HF06	D20 Z06 K28 APXT 10	20	6	28	20	120	0,265		₺2.617
HF07	D25 Z08 K37 APXT 10	25	8	37	25	120	0,404		₺3.333
HF08	D32 Z15 K46 APXT 10	32	15	46	32	120	0,627		₺4.562
HF09	D40 Z18 K55 APXT 10	40	18	55	32	125	0,873		₺5.355
HF10	D20 Z06 K28 APXT 10	20	6	28	20	150	0,326	APXT 1003	₺2.617
HF11	D25 Z08 K37 APXT 10	25	8	37	25	150	0,515	KRLY	₺3.333
HF12	D32 Z15 K46 APXT 10	32	15	46	32	150	1,120		₺4.562
HF13	D40 Z18 K55 APXT 10	40	18	55	32	150	1,100		₺5.355
HF15	D20 Z06 K28 APXT 10	20	6	28	20	200	0,481		₺2.617
HF16	D25 Z08 K37 APXT 10	25	8	37	25	200	0,727		₺3.333
HF17	D32 Z15 K46 APXT 10	32	15	46	32	200	1,144		₺4.562
HF18	D40 Z18 K55 APXT 10	40	18	55	32	200	1,621		₺5.355



 TC060 M2,5x5,5
  T8
 

KRLY ucuna uygundur.

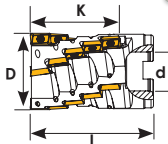
APKT 1604



Sipariş Kodu	Ürün Kodu	Ölçüler (mm)						Uç	Fiyat
		D	Z	K	d	L	kg		
HF52	D63 Z20 K75 APKT 16	63	20	75	32	100	1,455	APKT 1604	₺6.345
HF53	D80 Z25 K75 APKT 16	80	25	75	32	100	2,645	KRLY	₺7.735
HF54	D100 Z30 K75 APKT 16	100	30	75	40	100	4,329		₺9.517

 TC074 M4x10
  T15
 

KRLY ucuna uygundur.

SCMT 09T3-1204

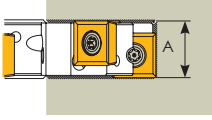
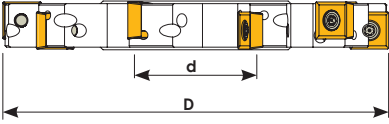
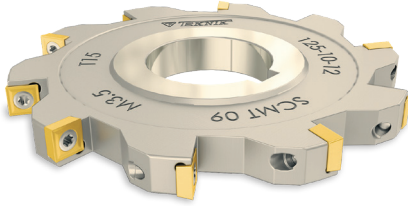

Sipariş Kodu	Ürün Kodu	Ölçüler (mm)					Uç	Fiyat
		D	A	Z	d	kg		
DF086	D080 A10 Z08 SCMT 09	80	10	8	27	0,229		₺1.964
DF092	D100 A10 Z08 SCMT 09	100	10	8	32	0,408		₺2.103
DF100	D125 A10 Z10 SCMT 09	125	10	10	40	0,612		₺2.874
DF108	D160 A10 Z12 SCMT 09	160	10	12	40	1,280		₺3.570
DF116	D200 A10 Z14 SCMT 09	200	10	14	40	1,738		₺4.324
DF088	D080 A12 Z08 SCMT 09	80	12	8	27	0,445	SCMT 09T3	₺1.964
DF094	D100 A12 Z08 SCMT 09	100	12	8	32	0,477	ISO.	₺2.103
DF102	D125 A12 Z10 SCMT 09	125	12	10	40	0,748		₺2.874
DF110	D160 A12 Z12 SCMT 09	160	12	12	40	1,313		₺3.570
DF118	D200 A12 Z14 SCMT 09	200	12	14	40	2,140		₺4.324
DF090	D080 A16 Z08 SCMT 12	80	16	8	27	0,564		₺1.964
DF096	D100 A16 Z08 SCMT 12	100	16	8	32	0,353		₺2.103
DF104	D125 A16 Z10 SCMT 12	125	16	10	40	0,927	SCMT 1204	₺2.874
DF112	D160 A16 Z12 SCMT 12	160	16	12	40	1,634	ISO.	₺3.570
DF120	D200 A16 Z14 SCMT 12	200	16	14	40	2,769		₺4.324
DF106	D125 A20 Z10 SCMT 12	125	20	10	40	1,167		₺2.874
DF114	D160 A20 Z12 SCMT 12	160	20	12	40	2,145		₺3.570

Kod	TC074 M4x10	T15
DF086-DF118	TC074 M4x10	T15
DF090-DF114	TC083 M5x12	T20

CCMT 0602-09T3-1204

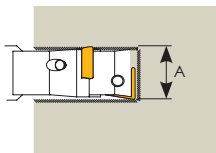
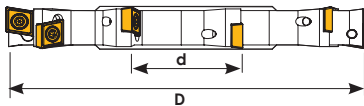
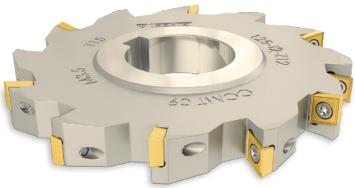

Sipariş Kodu	Ürün Kodu	Ölçüler (mm)					Uç	Fiyat
		D	A	Z	d	kg		
DF150	D080 A08 Z10 CCMT 06	80	8	10	27	0,236		₺1.964
DF160	D100 A08 Z12 CCMT 06	100	8	12	32	0,365		₺2.103
DF170	D125 A08 Z14 CCMT 06	125	8	14	40	0,512		₺2.874
DF182	D160 A08 Z16 CCMT 06	160	8	16	40	0,996	CCMT 0602	₺3.570
DF194	D200 A08 Z18 CCMT 06	200	8	18	40	1,587	ISO.	₺4.324
DF152	D080 A10 Z10 CCMT 06	80	10	10	27	0,289		₺1.964
DF162	D100 A10 Z12 CCMT 06	100	10	12	32	0,453		₺2.103
DF172	D125 A10 Z14 CCMT 06	125	10	14	40	0,703		₺2.874
DF184	D160 A10 Z16 CCMT 06	160	10	16	40	1,228		₺3.570
DF196	D200 A10 Z18 CCMT 06	200	10	18	40	2,035		₺4.324
DF154	D080 A12 Z08 CCMT 09	80	12	8	27	0,470		₺1.970
DF164	D100 A12 Z10 CCMT 09	100	12	10	32	0,472		₺2.103
DF174	D125 A12 Z12 CCMT 09	125	12	12	40	0,750		₺2.874
DF186	D160 A12 Z14 CCMT 09	160	12	14	40	1,360	CCMT 09T3	₺3.570
DF198	D200 A12 Z16 CCMT 09	200	12	16	40	2,400	ISO.	₺4.324
DF156	D080 A14 Z08 CCMT 09	80	14	8	27	0,335		₺1.964
DF166	D100 A14 Z10 CCMT 09	100	14	10	32	0,552		₺2.103
DF176	D125 A14 Z12 CCMT 09	125	14	12	40	0,871		₺2.874
DF188	D160 A14 Z14 CCMT 09	160	14	14	40	1,535		₺3.570
DF200	D200 A14 Z16 CCMT 09	200	14	16	40	2,575		₺4.324
DF158	D080 A16 Z06 CCMT 12	80	16	6	27	0,545		₺1.964
DF168	D100 A16 Z08 CCMT 12	100	16	8	32	0,567		₺2.103
DF178	D125 A16 Z10 CCMT 12	125	16	10	40	1,121	CCMT 1204	₺2.874
DF190	D160 A16 Z12 CCMT 12	160	16	12	40	1,727	ISO.	₺3.570
DF180	D125 A20 Z10 CCMT 12	125	20	10	40	1,430		₺2.874
DF192	D160 A20 Z12 CCMT 12	160	20	12	40	2,650		₺3.570

Kod	TC063 M2,5x7	T8
DF150-DF196	TC063 M2,5x7	T8
DF0154-DF200	TC067 M3,5x8,5	T15
DF0158-DF192	TC083 M5x12	T20

Kalite için TEKNİK çözüm
Technical solution for quality



T-Slot Milling Cutter



www.teknikcuttingtools.com



Kalite için TEKNİK çözüm

Technical solution for quality

36-38



CCMT 0602-09T3-1204

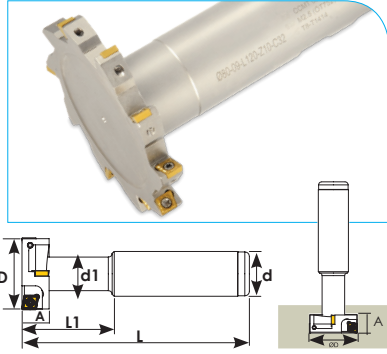

Sipariş Kodu	Ürün Kodu	Ölçüler (mm)								Uç	Fiyat
		D	A	Z	d	d1	L	L1			
TKÇ096	D17 A08 Z02 CCMT 06	17	8	2	16	10	100	28	0,145	CCMT 0602	₺1.032
TKÇ098	D21 A09 Z02 CCMT 06	21	9	2	16	11	100	31,5	0,151	ISO.	₺1.032
TKÇ100	D25 A11 Z04 CCMT 06	25	11	4	20	15	100	32,5	1,232		₺1.110
TKÇ102	D32 A12 Z04 CCMT 06	32	12	4	20	15	100	40	0,300		₺1.174
TKÇ103	D32 A14 Z04 CCMT 09	32	14	4	25	16	100	33	0,434	CCMT 09T3	₺1.174
TKÇ104	D35 A15 Z04 CCMT 09	35	15	4	25	14	100	52	0,447	ISO.	₺1.191
TKÇ106	D40 A17 Z04 CCMT 09	40	17	4	25	20	110	50	0,509		₺1.191
TKÇ108	D50 A20 Z04 CCMT 12	50	20	4	32	26	110	50	0,691	CCMT 1204 ISO	₺1.191
TKÇ120	D63 A09 Z08 CCMT 06	63	9	8	32	19,5	125	37	0,842	CCMT 0602	₺2.341
TKÇ122	D80 A09 Z10 CCMT 06	80	9	10	31,5	32	120	32	1,025	ISO.	₺2.341

Kod		
TKÇ096-TKÇ102	TC060 M2,5x5,5	T8
TKÇ103-TKÇ106	TC067 M3,5x8,5	T15
TKÇ108	TC083 M5x12	T20
TKÇ120-TKÇ122	TC060 M2,5x5,5	T8

SPMG 05-06-07

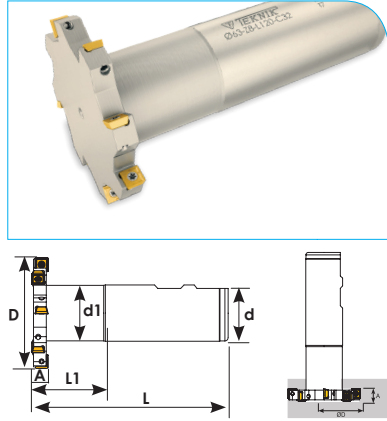

Sipariş Kodu	Ürün Kodu	Ölçüler (mm)								Uç	Fiyat
		D	A	Z	d	d1	L	L1			
TKÇ050	D50 A05 Z07 SPMG 05	50	5	7	32	31,5	120	45	0,830	SPMG 05	₺1.825
TKÇ052	D63 A05 Z08 SPMG 05	63	5	8	32	31,5	120	45	0,861	TGTC.	₺1.964
TKÇ054	D50 A06 Z07 SPMG 06	50	6	7	32	31,5	120	45	0,833		₺1.825
TKÇ056	D63 A06 Z08 SPMG 06	63	6	8	32	31,5	120	45	0,850	SPMG 06	₺1.964
TKÇ058	D80 A06 Z10 SPMG 06	80	6	10	32	31,5	120	45	0,944	TGTC.	₺2.220
TKÇ060	D50 A08 Z06 SPMG 06	50	8	6	32	31,5	120	45	0,839		₺1.825
TKÇ062	D63 A08 Z08 SPMG 06	63	8	8	32	31,5	120	45	0,874		₺1.964
TKÇ064	D80 A08 Z10 SPMG 06	80	8	10	32	31,5	120	45	0,995		₺2.220
TKÇ066	D50 A10 Z06 SPMG 07	50	10	6	32	31,5	120	45	0,496	SPMG 07	₺1.825
TKÇ068	D63 A10 Z08 SPMG 07	63	10	8	32	31,5	120	45	0,868	TGTC.	₺1.964
TKÇ070	D80 A10 Z10 SPMG 07	80	10	10	32	31,5	120	45	0,994		₺2.220

Kod		
TKÇ050-TKÇ052	TC058 M2x4,2	T6
TKÇ054-TKÇ064	TC059 M2,2x5	T7
TKÇ066-TKÇ070	TC063 M2,5x7	T8

TGTC ucuna uygundur.

Round Milling Cutter

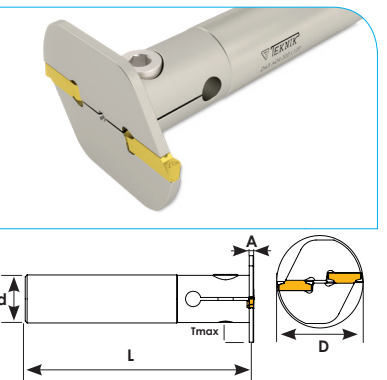

Sipariş Kodu	Ürün Kodu	Ölçüler (mm)						Uç	Fiyat	
		D	A	Z	L	d	Tmax			
TKÇ300	D50 A03 Z02 L-120	50	3	2	120	25	12,75	0,498	MGM 3C	₺1.469
TKÇ301	D63 A03 Z02 L-120	63	3	2	120	25	19,25	0,543	KRLY.	₺1.528
TKÇ302	D80 A03 Z02 L-120	80	3	2	120	32	24,25	0,841		₺1.746
TKÇ303	D50 A04 Z02 L-120	50	4	2	120	25	12,75	0,536	MGM 4C	₺1.469
TKÇ304	D63 A04 Z02 L-120	63	4	2	120	25	19,25	0,556	KRLY.	₺1.528
TKÇ305	D80 A04 Z02 L-120	80	4	2	120	32	24,25	0,860		₺1.746
TKÇ306	D55 A05 Z02 L-120	55	5	2	120	25	15,25	0,513	MGM 5C	₺1.469
TKÇ307	D63 A05 Z02 L-120	63	5	2	120	25	19,25	0,529	KRLY.	₺1.528
TKÇ308	D80 A05 Z02 L-120	80	5	2	120	32	24,25	0,860		₺1.746

	TC136 M8		6 Allen
--	----------	--	---------

KRLY ucuna uygundur.

TCMT 1102 16T3

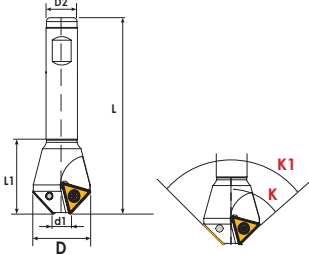
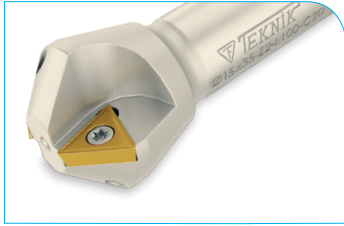

Sipariş Kodu	Ürün Kodu	Ölçüler (mm)										Uç	Fiyat
		K	K1	d1	D	Z	d2	L	L1	(kg)			
S337	06-20 Z01 K30° TCMT 16	30°	60°	6	20	1	16	100	37	0,170	TCMT 16T3	₺556	
S345	10-34 Z02 K30° TCMT 16	30°	60°	10	34	2	20	100	40	0,307	TCMT 16T3	₺636	
S343	24-39 Z02 K30° TCMT 16	30°	60°	24	39	2	20	100	36	0,356	TCMT 16T3	₺636	
S334	04-16 Z01 K45° TCMT 11	45°	90°	4	16	1	16	100	35	0,140	TCMT 1102	₺556	
S341	06-24 Z01 K45° TCMT 16	45°	90°	6	24	1	20	100	30	0,256	TCMT 16T3	₺556	
S336	10-31 Z02 K45° TCMT 16	45°	90°	10	31	2	16	100	35	0,204	TCMT 16T3	₺636	
S338	14-35 Z02 K45° TCMT 16	45°	90°	14	35	2	20	100	35	0,324	TCMT 16T3	₺636	
S340	22-43 Z03 K45° TCMT 16	45°	90°	22	43	3	25	100	37	0,634	TCMT 16T3	₺696	
S342	32-53 Z03 K45° TCMT 16	45°	90°	32	53	3	25	100	37	0,634	TCMT 16T3	₺696	
S335	02-18 Z01 K60° TCMT 11	60°	120°	2	18	1	16	100	35	0,157	TCMT 1102	₺556	
S339	10-31 Z02 K60° TCMT 16	60°	120°	10	31	2	16	100	35	0,213	TCMT 16T3	₺636	
Kod													
S337-S343, S341-S342, S339		TC067 M3,5x8,5		T15									
S334, S335		TC060 M2,5x5,5		T8									

Açılı Havşa

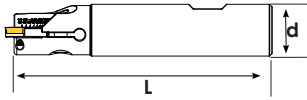

Sipariş Kodu	Ürün Kodu	Ölçüler (mm)						Uç	Fiyat
		D min	D max	d	L	γ°	(kg)		
AH10	D20 R1 L100 TCMT 11	5	27	20	100	10-80	0,241	TCMT 1102 ISO.	₺1.448
AH15	D25 R1 L100 TCMT 16	5	34	25	100	10-80	0,370	TCMT 16T3 ISO.	₺1.489
Kod									
AH10	AH20 TCMT 11	TC063M2,5x7		M5x12		T8			
AH15	AH21 TCMT 16	TC067 M3,5x8,5		M6x15		T15			

TWX 16R

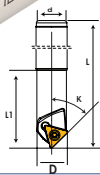
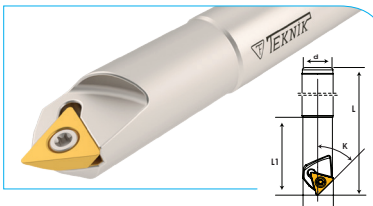

Sipariş Kodu	Ürün Kodu	Ölçüler (mm)							Uç	Fiyat	
		K	D	Z	L	d	L1	(kg)			
S352	D21 d20 Z01 L110 TWX 16	45°	21	1	110	20	50	0,260	TWX 16R-KRLY	₺775	
Kod											
		TC072 M4x10		T15							

KRLY ucuna uygundur.

SOMT 11T3

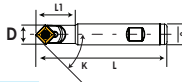

Sipariş Kodu	Ürün Kodu	Ölçüler (mm)							Uç	Fiyat	
		K	D	Z	L	d	L1	(kg)			
S769	D16 d16 Z01 L100 SOMT 11	45°	16	1	100	16	32	0,153	SOMT 11T3	₺736	
S770	D16 d16 Z01 L150 SOMT 11	45°	16	1	150	16	32	0,238	PLBT	₺814	
Kod											
		TC067 M3,5x8,5		T15							

PLBT ucuna uygundur.

Back Facing Milling

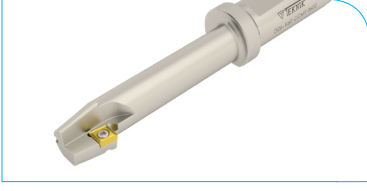

Sipariş Kodu	Ürün Kodu	Ölçüler (mm)								Uç	Fiyat
		D	Dmin	K	L	L1	L2	D1			
C100	D18 K40 CCMT 06	18	10	40	47	60	110	20	0,194	CCMT 060204	₺1.110
C102	D20 K45 CCMT 06	20	12	45	52	67	117	20	0,210	ISO.	₺1.110
C104	D26 K60 CCMT 06	26	17	60	67	82	132	20	0,261		₺1.110
C106	D33 K75 CCMT 09	33	21	75	82	102	152	20	0,308	CCMT 09T304 ISO.	₺1.110
Kod											
C100-C104		TC060 M2,5x5				T8					
C106		TC067 M3,5x8,5				T15					

RHKW 1003

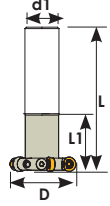

Sipariş Kodu	Ürün Kodu	Ölçüler (mm)						Uç	Fiyat
		D	Z	L	d	L1			
TKÇ200	D40 d20 Z04 L100 RHKW 10	40	4	100	20	40	0,285	RHKW 1003	₺1.291
TKÇ202	D50 d25 Z05 L120 RHKW 10	50	5	120	25	40	0,284	INGRSLL.	₺1.429

INGRSLL ucuna uygundur.

45° SPMG 0904

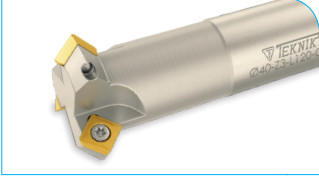

Sipariş Kodu	Ürün Kodu	Ölçüler (mm)						Uç	Fiyat
		D	Z	L	d	L1			
S060	D32 d25 Z02 L150 SPMT 09	32	2	150	25	30	0,589	SPMG 0904	₺1.032
S062	D40 d25 Z03 L150 SPMT 09	40	3	150	25	50	0,562	TGTC.	₺1.110

TGTC ucuna uygundur.

55° DCMT 11T3 - 35° VBMT 1604

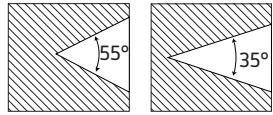
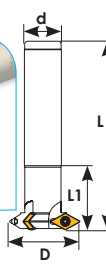

Sipariş Kodu	Ürün Kodu	Ölçüler (mm)						Uç	Fiyat
		D	Z	L	d	L1			
S070	D50 d25 Z03 L120 DCMT 11	50	3	120	25	40	0,584	DCMT 11T3 ISO.	₺1.291
S072	D63 d25 Z04 L120 DCMT 11	63	4	120	25	40	0,536		₺1.429
S073	D75 d25 Z03 L130 VBMT 16	75	3	130	25	40	0,924	VBMT 1604 ISO.	₺1.489
Kod									
S070-S072		TC067 M3.5X9				T15			
S073		TC074 M4x10							

55° DCMT 11T3

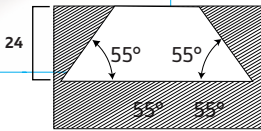
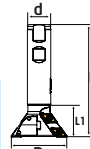
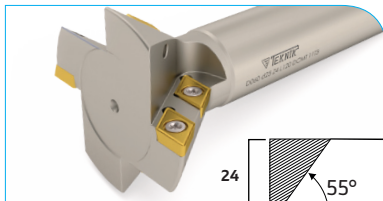

Sipariş Kodu	Ürün Kodu	Ölçüler (mm)						Uç	Fiyat
		D	Z	L	d	L1			
TKÇ251	D60 d25 Z04 L120 DCMT 11	60	4	120	25	35	0,583	DCMT 11T3 ISO.	₺1.746

60° DCMT 11T3

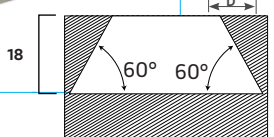
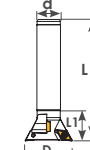
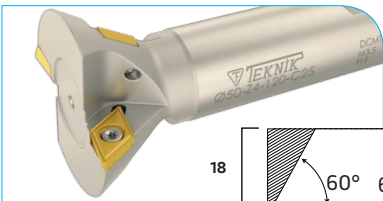

Sipariş Kodu	Ürün Kodu	Ölçüler (mm)						Uç	Fiyat
		D	Z	L	d	L1			
TKÇ250	D50 d25 Z04 L120 DCMT 11	50	4	120	25	30	0,521	DCMT 11T3 ISO.	₺1.746

Saplı Tarama



www.teknikcuttingtools.com



Kalite için TEKNIK çözüm

Technical solution for quality

40-55



APXT 1003

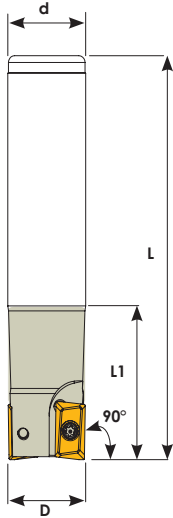

Sipariş Kodu	Ürün Kodu	Ölçüler (mm)							Uç	Fiyat
		D	Z	L	d	L1				
S136	D12 d12 Z01 L100 APXT 10	12	1	100	12	27	0,097		₺556	
S138	D14 d14 Z01 L100 APXT 10	14	1	100	14	30	0,126		₺556	
S140	D16 d16 Z02 L100 APXT 10	16	2	100	16	30	0,156		₺696	
S142	D18 d16 Z02 L100 APXT 10	18	2	100	16	30	0,162		₺696	
S144	D20 d20 Z03 L100 APXT 10	20	3	100	20	30	0,231		₺736	
S146	D22 d20 Z03 L100 APXT 10	22	3	100	20	30	0,243		₺736	
S148	D25 d25 Z03 L100 APXT 10	25	3	100	25	35	0,365		₺736	
S150	D30 d25 Z04 L100 APXT 10	30	4	100	25	40	0,400		₺892	
S152	D32 d25 Z04 L100 APXT 10	32	4	100	25	35	0,415		₺892	
S154	D35 d25 Z04 L100 APXT 10	35	4	100	25	30	0,452		₺892	
S156	D40 d25 Z05 L100 APXT 10	40	5	100	25	30	0,477		₺1.032	
S158	D12 d12 Z01 L120 APXT 10	12	1	120	12	27	0,112		₺597	
S160	D14 d14 Z01 L120 APXT 10	14	1	120	14	30	0,150		₺597	
S162	D16 d16 Z02 L120 APXT 10	16	2	120	16	40	0,185	APXT 1003	₺736	
S164	D18 d16 Z02 L120 APXT 10	18	2	120	16	45	0,190	KRLY.	₺736	
S166	D20 d20 Z03 L120 APXT 10	20	3	120	20	40	0,278		₺794	
S168	D22 d20 Z03 L120 APXT 10	22	3	120	20	40	0,290		₺794	
S169	D25 d25 Z03 L120 APXT 10	25	3	120	25	40	0,452		₺794	
S170	D30 d25 Z04 L120 APXT 10	30	4	120	25	40	0,487		₺974	
S171-1	D32 d25 Z04 L120 APXT 10	32	4	120	25	40	0,511		₺974	
S171	D35 d25 Z04 L120 APXT 10	35	4	120	25	40	0,532		₺974	
S172	D40 d25 Z05 L120 APXT 10	40	5	120	25	40	0,606		₺1.110	
S173	D16 d16 Z02 L150 APXT 10	16	2	150	16	50	0,230		₺872	
S174	D18 d16 Z02 L150 APXT 10	18	2	150	16	50	0,246		₺872	
S176	D20 d20 Z03 L150 APXT 10	20	3	150	20	60	0,345		₺935	
S178	D22 d20 Z03 L150 APXT 10	22	3	150	20	60	0,360		₺935	
S180	D25 d25 Z03 L150 APXT 10	25	3	150	25	60	0,563		₺935	
S180-1	D30 d25 Z04 L150 APXT 10	30	4	150	25	60	0,610		₺1.073	
S181	D32 d32 Z04 L150 APXT 10	32	4	150	32	45	0,916		₺1.073	
S182	D16 d16 Z02 L200 APXT 10	16	2	200	16	60	0,480		₺993	
S184	D18 d16 Z02 L200 APXT 10	18	2	200	16	60	0,350		₺993	
S186	D20 d20 Z03 L200 APXT 10	20	3	200	20	70	0,500		₺1.110	
S187	D22 d20 Z03 L200 APXT 10	22	3	200	20	70	0,513		₺1.110	
S188	D25 d25 Z03 L200 APXT 10	25	3	200	25	60	0,771		₺1.110	
S188-1	D30 d25 Z04 L200 APXT 10	30	4	200	25	50	0,845		₺1.310	
S189	D32 d32 Z04 L200 APXT 10	32	4	200	32	60	1,253		₺1.310	
S190	D16 d16 Z02 L250 APXT 10	16	2	250	16	70	0,415		₺1.330	
S192	D20 d20 Z03 L250 APXT 10	20	3	250	20	70	0,623		₺1.507	
S194	D25 d25 Z03 L250 APXT 10	25	3	250	25	70	0,953		₺1.507	

 TC060 M2,5x5,5

 T8

KRLY ucuna uygundur.

APKT 1604

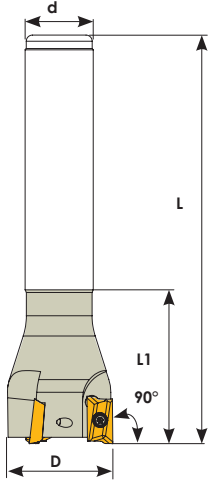
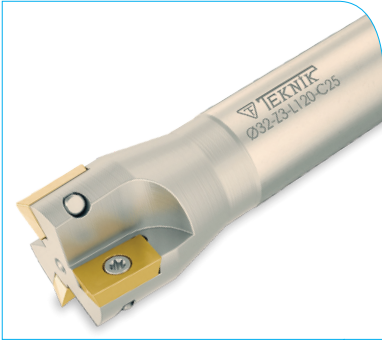



Sipariş Kodu	Ürün Kodu	Ölçüler (mm)							Uç	Fiyat
		D	Z	L	d	L1				
S256	D25 d25 Z02 L120 APKT 16	25	2	120	25	45	0,430		₺696	
S258	D30 d25 Z03 L120 APKT 16	30	3	120	25	45	0,460		₺872	
S260	D32 d25 Z03 L120 APKT 16	32	3	120	25	45	0,469		₺872	
S262	D35 d25 Z03 L120 APKT 16	35	3	120	25	45	0,498		₺872	
S264	D40 d25 Z04 L120 APKT 16	40	4	120	25	45	0,547		₺950	
S266	D25 d25 Z02 L150 APKT 16	25	2	150	25	55	0,544		₺892	
S268	D30 d25 Z03 L150 APKT 16	30	3	150	25	55	0,575		₺993	
S270	D32 d32 Z03 L150 APKT 16	32	3	150	32	55	0,876	APKT 1604	₺993	
S272	D35 d32 Z03 L150 APKT 16	35	3	150	32	55	0,915	KRLY.	₺993	
S274	D40 d32 Z04 L150 APKT 16	40	4	150	32	55	0,960		₺1.032	
S276	D25 d25 Z02 L200 APKT 16	25	2	200	25	65	0,750		₺1.014	
S278	D30 d25 Z03 L200 APKT 16	30	3	200	25	55	0,783		₺1.110	
S280	D32 d32 Z03 L200 APKT 16	32	3	200	32	55	1,218		₺1.110	
S282	D35 d32 Z03 L200 APKT 16	35	3	200	32	55	1,245		₺1.110	
S283	D40 d32 Z04 L200 APKT 16	40	4	200	32	55	1,296		₺1.232	
S432	D25 d25 Z02 L250 APKT 16	25	2	250	25	70	0,939		₺1.291	
S434	D30 d25 Z03 L250 APKT 16	30	3	250	25	55	1,028		₺1.347	
S436	D32 d32 Z03 L250 APKT 16	32	3	250	32	60	1,520		₺1.347	
S438	D35 d32 Z03 L250 APKT 16	35	3	250	32	65	1,567		₺1.347	
S440	D40 d32 Z04 L250 APKT 16	40	4	250	32	60	1,612		₺1.448	
S442	D25 d25 Z02 L300 APKT 16	25	2	300	25	70	1,127		₺1.429	
S444	D30 d25 Z03 L300 APKT 16	30	3	300	25	60	1,168		₺1.507	
S446	D32 d32 Z03 L300 APKT 16	32	3	300	32	70	1,827		₺1.507	
S448	D35 d32 Z03 L300 APKT 16	35	3	300	32	65	1,879		₺1.507	
S450	D40 d32 Z04 L300 APKT 16	40	4	300	32	70	1,922		₺1.648	
S453	D32 d32 Z03 L350 APKT 16	32	3	350	32	80	2,274		₺1.746	
S454	D35 d32 Z03 L350 APKT 16	35	3	350	32	65	2,332		₺1.746	
S456	D40 d32 Z04 L350 APKT 16	40	4	350	32	55	2,375		₺1.866	



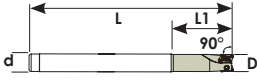
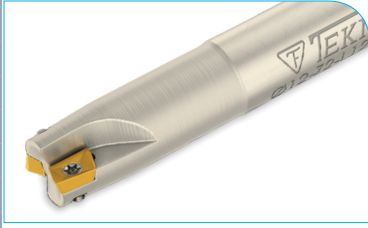

KRLY ucuna uygundur.

APMT 0602





Sipariş Kodu	Ürün Kodu	Ölçüler (mm)						Uç	Fiyat
		D	Z	L	d	L1			
S003	D10 d10 Z02 L080 APMT 06	10	2	80	10	20	0,041		₺855
S004	D12 d12 Z03 L080 APMT 06	12	3	80	12	25	0,060		₺1.053
S005	D16 d16 Z04 L090 APMT 06	16	4	90	16	25	0,120		₺1.209
S006	D20 d20 Z05 L110 APMT 06	20	5	110	20	30	0,240	APMT 0602	₺1.385
S007	D25 d25 Z07 L120 APMT 06	25	7	120	25	30	0,411	KRLY.	₺1.560
S008	D32 d32 Z08 L120 APMT 06	32	8	120	32	35	0,686		₺1.736
S009	D10 d10 Z02 L120 APMT 06	10	2	120	10	30	0,085		₺855
S011	D12 d12 Z02 L120 APMT 06	12	2	120	12	30	0,120		₺855

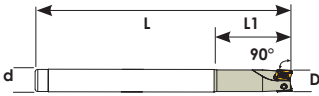

 TC057-1 M1,8x4,1
  T6
 

KRLY ucuna uygundur.

APMT 11T3



Sipariş Kodu	Ürün Kodu	Ölçüler (mm)						Uç	Fiyat
		D	Z	L	d	L1			
S222	D10 d10 Z01 L085 APMT 11	10	1	85	10	20	0,059		₺556
S224	D12 d16 Z01 L085 APMT 11	12	1	85	16	25	0,126		₺556
S226	D14 d16 Z01 L090 APMT 11	14	1	90	16	25	0,139		₺556
S228	D16 d16 Z02 L090 APMT 11	16	2	90	16	25	0,138		₺696
S230	D16 d16 Z02 L180 APMT 11	16	2	180	16	30	0,280	APMT 11T3	₺974
S232	D20 d20 Z02 L100 APMT 11	20	2	100	20	30	0,243	KRLY.	₺696
S234	D20 d20 Z02 L210 APMT 11	20	2	210	20	30	0,523		₺993
S236	D25 d25 Z03 L115 APMT 11	25	3	115	25	35	0,423		₺736
S238	D25 d25 Z03 L180 APMT 11	25	3	180	25	40	0,749		₺935
S240	D32 d32 Z04 L125 APMT 11	32	4	125	32	40	0,764		₺950
S242	D32 d32 Z04 L180 APMT 11	32	4	180	32	50	1,123		₺1.310

Kod
 TC060 N2,5x5,5
  T8
 



S222-S238 TC061 M2,5x6,5
 S240-S242 TC061 M2,5x6,5

KRLY ucuna uygundur.

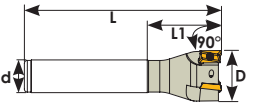
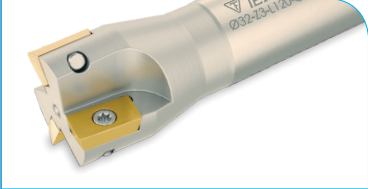
APMT 1604





Sipariş Kodu	Ürün Kodu	Ölçüler (mm)						Uç	Fiyat
		D	Z	L	d	L1			
S244	D25 d25 Z02 L120 APMT 16	25	2	120	25	45	0,430		₺696
S245	D25 d25 Z02 L150 APMT 16	25	2	150	25	55	0,610	APMT 1604	₺892
S247	D32 d25 Z03 L120 APMT 16	32	3	120	25	45	0,495	KRLY.	₺872
S248	D32 d32 Z03 L150 APMT 16	32	3	150	32	55	0,874		₺993
S250	D40 d25 Z04 L120 APMT 16	40	4	120	25	45	0,544		₺950
S251	D40 d32 Z04 L150 APMT 16	40	4	150	32	55	1,294		₺1.032

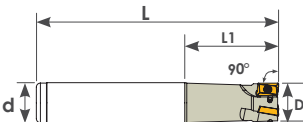

 TC074 M4x10
  T15
 

KRLY ucuna uygundur.

APKT 1003-1604



Sipariş Kodu	Ürün Kodu	Ölçüler (mm)						Uç	Fiyat
		D	Z	L	d	L1			
S031	D16 d16 Z02 L100 APKT 10	16	2	100	16	30	0,275		₺714
S032	D20 d20 Z03 L100 APKT 10	20	3	100	20	30	0,342		₺755
S033	D25 d25 Z03 L100 APKT 10	25	3	100	25	35	0,376	APKT 1003	₺755
S034	D32 d25 Z04 L100 APKT 10	32	4	100	25	35	0,768	YG1	₺892
S035	D16 d16 Z02 L150 APKT 10	16	2	150	16	50	0,320		₺855
S036	D20 d20 Z03 L150 APKT 10	20	3	150	20	60	0,368		₺935
S037	D25 d25 Z03 L150 APKT 10	25	3	150	25	60	0,541		₺935
S038	D32 d32 Z04 L150 APKT 10	32	4	150	32	45	0,946		₺1.110
S046	D40 d25 Z04 L120 APKT 16	40	4	120	25	45	0,516	APKT 1604 YG1	₺993

Kod
 TC060 M2,5x5,5
  T8
 

S031-S032,S035-S036 TC063 M2,5x7
 S033-S034,S038 TC074 M4x10
 S046 TC074 M4x10

YG1 ucuna uygundur.

R390-11T3

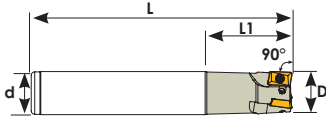
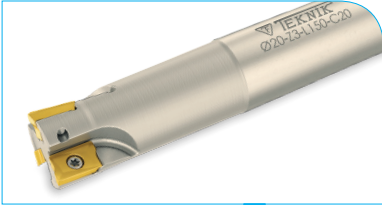

Sipariş Kodu	Ürün Kodu	Ölçüler (mm)						Uç	Fiyat
		D	Z	L	d	L1			
S591	D16 d16 Z02 L120 R390 11	16	2	120	16	40	0,180		₺736
S592	D20 d20 Z03 L120 R390 11	20	3	120	20	40	0,270		₺794
S592-1	D25 d25 Z03 L120 R390 11	25	3	120	25	45	0,446		₺794
S593	D16 d16 Z02 L150 R390 11	16	2	150	16	40	0,229	R390-11T3	₺872
S594	D20 d20 Z03 L150 R390 11	20	3	150	20	50	0,348	SNDVK.	₺872
S594-1	D21 d20 Z03 L150 R390 11	21	3	150	20	50	0,366		₺935
S595	D25 d25 Z03 L150 R390 11	25	3	150	25	50	0,557		₺935
S595-1	D26 d25 Z04 L150 R390 11	26	4	150	25	50	0,557		₺1.073
S596	D20 d20 Z03 L200 R390 11	20	3	200	20	50	0,480		₺1.110
S597	D25 d25 Z03 L200 R390 11	25	3	200	25	50	0,762		₺1.110
S598	D25 d25 Z03 L250 R390 11	25	3	250	25	60	0,951		₺1.507
Kod									
S591,S593, S594-1,S596		TC060 M2,5x5,5							
S592,S592-1,S594,S595,S595-1		TC063 M2,5x7				T8			
S597,S598									

SNDVK ucuna uygundur.

R390-1704

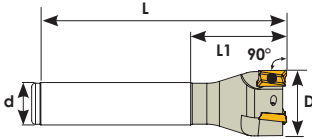
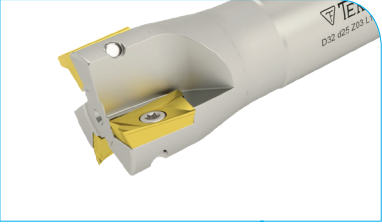

Sipariş Kodu	Ürün Kodu	Ölçüler (mm)						Uç	Fiyat
		D	Z	L	d	L1			
S510	D25 d25 Z02 L120 R390 17	25	2	120	25	45	0,425		₺696
S512	D30 d25 Z03 L120 R390 17	30	3	120	25	45	0,461		₺872
S514	D32 d25 Z03 L120 R390 17	32	3	120	25	45	0,459		₺872
S518	D40 d32 Z04 L120 R390 17	40	4	120	32	45	0,782		₺974
S520	D25 d25 Z02 L150 R390 17	25	2	150	25	55	0,536	R390-1704	₺892
S522	D30 d25 Z03 L150 R390 17	30	3	150	25	55	0,582	SNDVK.	₺993
S524	D32 d32 Z03 L150 R390 17	32	3	150	32	55	0,854		₺993
S528	D40 d32 Z04 L150 R390 17	40	4	150	32	55	0,936		₺1.014
S530	D25 d25 Z02 L200 R390 17	25	2	200	25	60	0,741		₺1.032
S532	D30 d25 Z03 L200 R390 17	30	3	200	25	55	0,773		₺1.092
S534	D32 d32 Z03 L200 R390 17	32	3	200	32	55	0,781		₺1.092
S538	D40 d32 Z04 L200 R390 17	40	4	200	32	55	1,272		₺1.232
				TC067 M3,5x8,5				T15	

SNDVK ucuna uygundur.

R390-1806

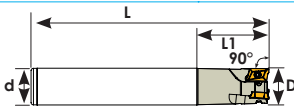
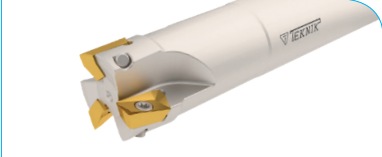

Sipariş Kodu	Ürün Kodu	Ölçüler (mm)						Uç	Fiyat
		D	Z	L	d	L1			
S603	D25 d25 Z02 L150 R390 18	25	2	150	25	60	0,530		₺892
S600	D25 d25 Z02 L200 R390 18	25	2	200	25	60	0,756	R390-1806	₺993
S605	D32 d32 Z03 L150 R390 18	32	3	150	32	60	0,850	SNDVK.	₺1.014
S601	D32 d32 Z03 L200 R390 18	32	3	200	32	60	1,188		₺1.092
				TC074 M4x10				T15	

SNDVK ucuna uygundur.

XOMX 0602- 0903-1204

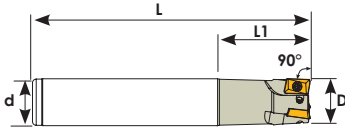
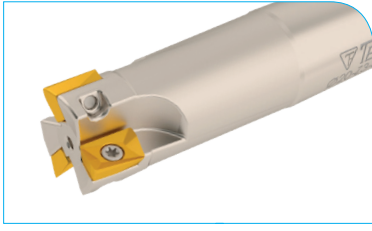

Sipariş Kodu	Ürün Kodu	Ölçüler (mm)						kg	Uç	Fiyat
		D	Z	L	d	L1				
S623	D10 d10 Z02 L120 XOMX 06	10	2	120	10	40	0,086	XOMX 0602	₺872	
S625	D12 d12 Z02 L120 XOMX 06	12	2	120	12	30	0,119	SCO.	₺872	
S627	D16 d16 Z02 L120 XOMX 09	16	2	120	16	45	0,197		₺755	
S626	D20 d20 Z03 L120 XOMX 09	20	3	120	20	40	0,297	XOMX 0903	₺814	
S629	D16 d16 Z02 L150 XOMX 09	16	2	150	16	45	0,228	SCO.	₺872	
S628	D20 d20 Z03 L150 XOMX 09	20	3	150	20	55	0,373		₺935	
S636	D20 d20 Z03 L200 XOMX 09	20	3	200	20	55	0,507		₺1.110	
S632	D25 d25 Z03 L150 XOMX 09	25	3	150	25	55	0,352		₺935	
S638	D20 d20 Z02 L120 XOMX 12	20	2	120	20	45	0,500		₺814	
S640	D20 d20 Z02 L150 XOMX 12	20	2	150	20	55	0,439		₺935	
S641	D20 d20 Z02 L200 XOMX 12	20	2	200	20	60	0,504	XOMX 1204	₺1.073	
S642	D25 d25 Z03 L120 XOMX 12	25	3	120	25	45	0,443	SCO.	₺814	
S643	D25 d25 Z03 L150 XOMX 12	25	3	150	25	55	0,574		₺935	
S644	D25 d25 Z03 L200 XOMX 12	25	3	200	25	60	0,779		₺1.110	
S645	D25 d25 Z03 L250 XOMX 12	25	3	250	25	70	0,856		₺1.507	
S647	D32 d32 Z04 L120 XOMX 12	32	4	120	25	45	0,965		₺950	
S648	D32 d32 Z04 L150 XOMX 12	32	4	150	32	55	0,937		₺1.073	
S650	D40 d32 Z04 L150 XOMX 12	40	4	150	32	45	1,047		₺1.073	

Kod			
S623-S625	TC057-1 M1,8x4	T6	
S627-S632	TC060 M2,5x5,5	T8	
S638-S650	TC069 M3,5x8,5	T10	

SCO ucuna uygundur.

APKT 0903

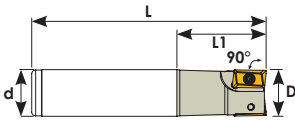
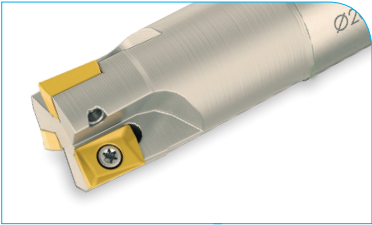

Sipariş Kodu	Ürün Kodu	Ölçüler (mm)						kg	Uç	Fiyat
		D	Z	L	d	L1				
S204	D16 d16 Z02 L120 APKT 09	16	2	120	16	40	0,185		₺736	
S206	D20 d20 Z03 L120 APKT 09	20	3	120	20	45	0,278	APKT 0903	₺794	
S208	D25 d25 Z03 L120 APKT 09	25	3	120	25	45	0,453	WLTR.	₺794	
S210	D16 d16 Z02 L150 APKT 09	16	2	150	16	50	0,237		₺872	
S212	D20 d20 Z03 L150 APKT 09	20	3	150	20	45	0,354		₺935	
S214	D25 d25 Z03 L150 APKT 09	25	3	150	25	45	0,590		₺935	
S216	D16 d16 Z02 L200 APKT 09	16	2	200	16	60	0,340		₺993	
S218	D20 d20 Z03 L200 APKT 09	20	3	200	20	60	0,502		₺1.110	
S220	D25 d25 Z03 L200 APKT 09	25	3	200	25	60	0,765		₺1.110	

Kod			
S204,S210,S216	TC060 M2,5x5,5	T8	
S206-S208,S212-S214,S218-S220	TC063 M2,5x7		

WLTR ucuna uygundur.

ADMT 1204

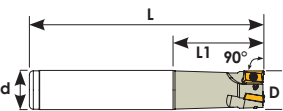
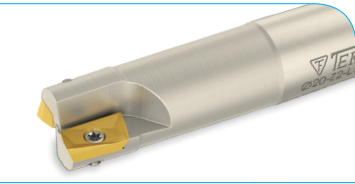

Sipariş Kodu	Ürün Kodu	Ölçüler (mm)						kg	Uç	Fiyat
		D	Z	L	d	L1				
S498	D20 d20 Z02 L120 ADMT 12	20	2	120	20	40	0,275		₺794	
S500	D20 d20 Z02 L150 ADMT 12	20	2	150	20	55	0,348	ADMT 1204	₺872	
S501	D20 d20 Z02 L200 ADMT 12	20	2	200	20	60	0,498	WLTR.	₺935	
S501-1	D25 d25 Z03 L120 ADMT 12	25	3	120	25	40	0,443		₺855	
S502	D25 d25 Z03 L150 ADMT 12	25	3	150	25	60	0,550		₺993	
S503	D30 d25 Z04 L150 ADMT 12	30	4	150	25	60	0,558		₺1.032	
S504	D32 d32 Z04 L150 ADMT 12	32	4	150	32	50	0,932		₺1.032	
S506	D40 d32 Z05 L150 ADMT 12	40	5	150	32	50	0,968		₺1.152	

Kod			
	TC067-1M3x7	T8	

WLTR ucuna uygundur.

ADMT 1606

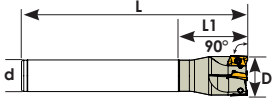
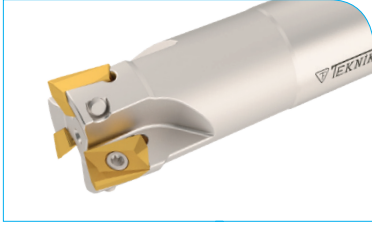

WLTR ucuna uygundur.

Sipariş Kodu	Ürün Kodu	Ölçüler (mm)							Uç	Fiyat
		D	Z	L	d	L1	kg			
S460	D25 d25 Z02 L150 ADMT 16	25	2	150	25	60	0,534		₺892	
S461	D25 d25 Z02 L200 ADMT 16	25	2	200	25	60	0,744	ADMT 1606	₺1.032	
S463	D26 d25 Z02 L150 ADMT 16	26	2	150	25	60	0,545	WLTR.	₺892	
S464	D26 d25 Z02 L200 ADMT 16	26	2	200	25	60	0,751		₺1.032	
S466	D32 d32 Z03 L150 ADMT 16	32	3	150	32	60	0,784		₺993	
S467	D32 d32 Z03 L200 ADMT 16	32	3	200	32	60	1,085		₺1.092	
S469	D40 d32 Z04 L150 ADMT 16	40	4	150	32	60	0,927		₺1.032	
S470	D40 d32 Z04 L200 ADMT 16	40	4	200	32	60	1,310		₺1.232	



AXMT 0602 - APKT 0903

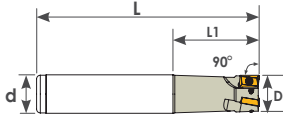
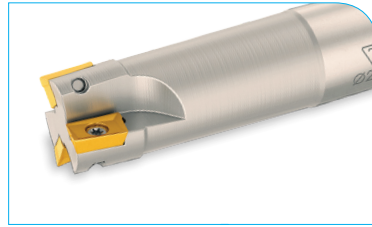

TGTC ucuna uygundur.

Sipariş Kodu	Ürün Kodu	Ölçüler (mm)							Uç	Fiyat
		D	Z	L	d	L1	kg			
S010	D10 d10 Z02 L120 AXMT 06	10	2	120	10	30	0,085	AXMT 0602	₺872	
S012	D12 d12 Z02 L120 AXMT 06	12	2	120	12	30	0,119	TGTC.	₺872	
S014	D16 d16 Z02 L120 APKT 09	16	2	120	16	40	0,195		₺755	
S016	D20 d20 Z03 L120 APKT 09	20	3	120	20	45	0,296		₺814	
S018	D25 d25 Z03 L120 APKT 09	25	3	120	25	45	0,447		₺814	
S020	D16 d16 Z02 L150 APKT 09	16	2	150	16	50	0,233	APKT 0903	₺872	
S022	D20 d20 Z03 L150 APKT 09	20	3	150	20	60	0,370	TGTC.	₺935	
S024	D25 d25 Z03 L150 APKT 09	25	3	150	25	60	0,583		₺935	

Kod

S010-S012

S14-S030

TC057-1M1,8x4

TC060 M2,5x5,5



T8



APKT 1705

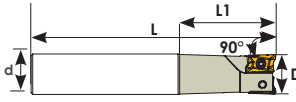

TGTC ucuna uygundur.

Sipariş Kodu	Ürün Kodu	Ölçüler (mm)							Uç	Fiyat
		D	Z	L	d	L1	kg			
S660	D25 d25 Z02 L150 APKT 17	25	2	150	25	60	0,534		₺892	
S660-1	D25 d25 Z02 L200 APKT 17	25	2	200	25	60	0,763	APKT 1705	₺1.032	
S662	D32 d32 Z03 L150 APKT 17	32	3	150	32	60	0,850	TGTC.	₺993	
S662-1	D32 d32 Z03 L200 APKT 17	32	3	200	32	60	1,236		₺1.092	
S664	D40 d32 Z04 L150 APKT 17	40	4	150	32	60	0,850		₺1.032	



APKT 1003

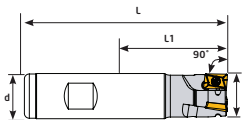
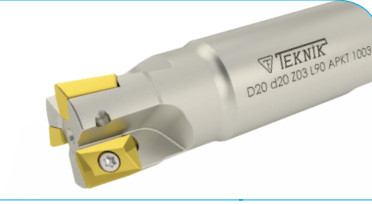

PLBT ucuna uygundur.

Sipariş Kodu	Ürün Kodu	Ölçüler (mm)							Uç	Fiyat
		D	Z	L	d	L1	kg			
S766	D16 d16 Z02 L085 APKT 10	16	2	85	16	26	0,123	APKT 1003	₺810	
S767	D20 d20 Z03 L090 APKT 10	20	3	90	20	28	0,209	PLBT	₺878	
S768	D25 d20 Z04 L150 APKT 10	25	4	150	20	26	0,388		₺1.239	

Yedek Part

Kod



TC060 M2,5x5,5







T8

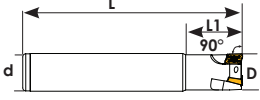

BDMT 11T3





Sipariş Kodu	Ürün Kodu	Ölçüler (mm)							Uç	Fiyat
		D	Z	L	d	L1				
S565	D16 d16 Z02 L150 BDMT 11	16	2	150	16	45	0,232		₺872	
S566	D18 d16 Z02 L150 BDMT 11	18	2	150	16	44	0,240	BDMT 11T3	₺872	
S567	D20 d20 Z03 L150 BDMT 11	20	3	150	20	50	0,351	KYCRA.	₺935	
S569	D25 d25 Z03 L150 BDMT 11	25	3	150	25	50	0,563		₺935	
S570	D25 d25 Z03 L200 BDMT 11	25	3	200	25	60	0,764		₺1.110	
S572	D32 d32 Z04 L150 BDMT 11	32	4	150	32	50	0,961		₺950	
S574	D32 d32 Z04 L200 BDMT 11	32	4	200	32	60	1,294		₺1.310	

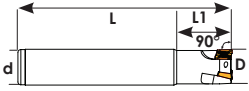
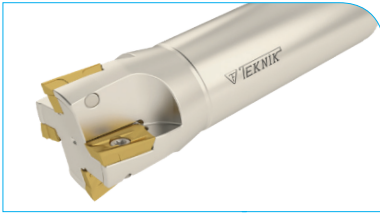

 TC060 M2,5x5,5
  T8
 

KYCRA ucuna uygundur.

BDMT 1704



Sipariş Kodu	Ürün Kodu	Ölçüler (mm)							Uç	Fiyat
		D	Z	L	d	L1				
S578	D25 d25 Z02 L120 BDMT 17	25	2	120	25	35	0,432		₺714	
S579	D25 d25 Z02 L150 BDMT 17	25	2	150	25	50	0,548	BDMT 1704	₺892	
S581	D32 d25 Z03 L120 BDMT 17	32	3	120	25	40	0,480	KYCRA.	₺872	
S582	D32 d32 Z03 L150 BDMT 17	32	3	150	32	60	0,895		₺993	
S584	D40 d32 Z04 L120 BDMT 17	40	4	120	32	40	0,790		₺950	
S585	D40 d32 Z04 L150 BDMT 17	40	4	150	32	40	0,985		₺1.014	

Kod
 TC073 M4x8,5
  T15
 



S578,S579 TC073 M4x8,5
 S581-S585 TC074 M4x10

KYCRA ucuna uygundur.

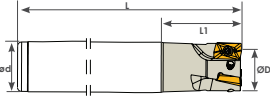
BOMT 1304





Sipariş Kodu	Ürün Kodu	Ölçüler (mm)							Uç	Fiyat
		D	Z	L	d	L1				
S850	D20 d20 Z02 L120 BOMT 13	20	2	120	20	40	0,289		₺775	
S851	D20 d20 Z02 L150 BOMT 13	20	2	150	20	40	0,356	BOMT 1304	₺855	
S852	D25 d25 Z03 L120 BOMT 13	25	3	120	25	40	0,451	INGRSL .	₺872	
S853	D25 d25 Z03 L150 BOMT 13	25	3	150	25	40	0,556		₺993	

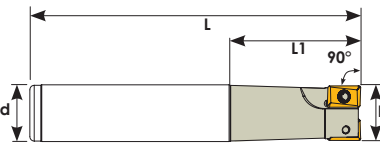
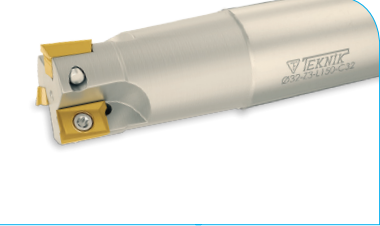

 TC069 M3,5x8,5
  T10
 

INGRSL ucuna uygundur.

ADKT 1505



Sipariş Kodu	Ürün Kodu	Ölçüler (mm)							Uç	Fiyat
		D	Z	L	d	L1				
S304	D25 d25 Z02 L120 ADKT 15	25	2	120	25	45	0,434		₺714	
S306	D30 d25 Z03 L120 ADKT 15	30	3	120	25	45	0,466		₺872	
S307	D32 d25 Z03 L120 ADKT 15	32	3	120	25	45	0,477		₺872	
S308	D35 d25 Z03 L120 ADKT 15	35	3	120	25	45	0,500		₺872	
S310	D40 d32 Z04 L120 ADKT 15	40	4	120	32	45	0,759		₺974	
S312	D25 d25 Z02 L150 ADKT 15	25	2	150	25	60	0,550	ADKT 1505	₺892	
S314	D30 d25 Z03 L150 ADKT 15	30	3	150	25	50	0,596	ISCR.	₺993	
S315	D32 d32 Z03 L150 ADKT 15	32	3	150	32	60	0,887		₺993	
S316	D35 d32 Z03 L150 ADKT 15	35	3	150	32	50	0,920		₺993	
S318	D25 d25 Z02 L200 ADKT 15	25	2	200	25	55	0,711		₺1.032	
S319	D30 d25 Z03 L200 ADKT 15	30	3	200	25	50	0,783		₺1.092	
S320	D32 d32 Z03 L200 ADKT 15	32	3	200	32	60	1,198		₺1.092	
S321	D35 d32 Z03 L200 ADKT 15	35	3	200	32	50	1,252		₺1.092	
S322	D40 d32 Z04 L200 ADKT 15	40	4	200	32	60	1,272		₺1.232	

 TC074 M4x10
  T15
 

ISCR ucuna uygundur.

ADMX 0702

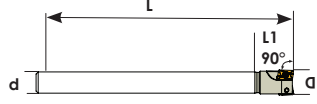

Sipariş Kodu	Ürün Kodu	Ölçüler (mm)						Uç	Fiyat
		D	Z	L	d	L1			
S751	D10 d10 Z02 L080 ADMX 07	10	2	80	10	16	0,062		₺794
S759	D16 d16 Z03 L160 ADMX 07	16	3	160	16	18	0,205	ADMX 0702	₺1.073
S760	D20 d20 Z04 L125 ADMX 07	20	4	125	20	17	0,293	PRMT.	₺1.152
S761	D20 d20 Z05 L125 ADMX 07	20	5	125	20	17	0,300		₺1.347

TC058 M2x4,2
 T6

PRMT ucuna uygundur.

3PKT 1004

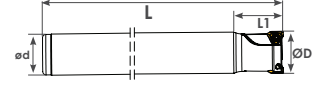

Sipariş Kodu	Ürün Kodu	Ölçüler (mm)						Uç	Fiyat
		D	Z	L	d	L1			
S485	D21 d20 Z02 L200 3PKT 10	21	2	200	20	30	1,259	3PKT 1004	₺1.073
S486	D26 d25 Z02 L200 3PKT 10	26	2	200	25	30	0,773	TGTC.	₺1.073
S487	D33 d32 Z03 L200 3PKT 10	33	3	200	32	40	0,495		₺1.152

TC093 M2,5x7
 T8

TGTC ucuna uygundur.

4NKT 06

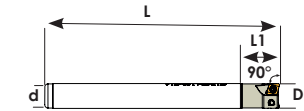
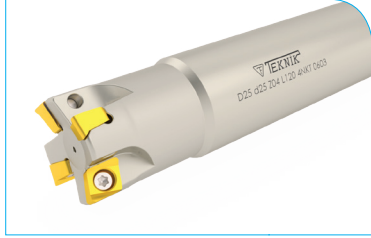

Sipariş Kodu	Ürün Kodu	Ölçüler (mm)						Uç	Fiyat
		D	Z	L	d	L1			
S471	D16 d16 Z02 L120 4NKT 06	16	2	120	16	25	0,200		₺993
S471-1	D16 d16 Z02 L150 4NKT 06	16	2	150	16	25	0,250	4NKT 06	₺1.032
S472	D17 d16 Z02 L150 4NKT 06	17	2	150	16	22	0,241	TGTC.	₺1.032
S473	D20 d20 Z03 L120 4NKT 06	20	3	120	20	25	0,306		₺1.073
S474	D21 d20 Z03 L200 4NKT 06	21	3	200	20	25	0,524		₺1.110
S475	D25 d25 Z04 L120 4NKT 06	25	4	120	25	30	0,474		₺1.131
S475-1	D25 d25 Z04 L200 4NKT 06	25	3	200	25	30	0,806		₺1.191
S476	D26 d25 Z03 L200 4NKT 06	26	3	200	25	30	0,815		₺1.191
S477	D33 d32 Z04 L200 4NKT 06	33	4	200	32	35	1,327		₺1.269
S477-1	D33 d32 Z04 L220 4NKT 06	33	4	220	32	35	1,462		₺1.291
S477-2	D40 d32 Z05 L200 4NKT 06	40	5	200	32	40	1,395		₺1.469

TC064 M3x6,5
 T8

TGTC ucuna uygundur.

XNKT 0604

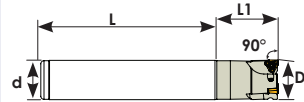

Sipariş Kodu	Ürün Kodu	Ölçüler (mm)						Uç	Fiyat
		D	Z	L	d	L1			
S834	D20 d20 Z02 L150 XNKT 06	20	2	150	20	40	0,365		₺1.052
S836	D21 d20 Z02 L150 XNKT 06	21	2	150	20	40	0,372	XNKT 0604	₺1.052
S838	D25 d25 Z03 L150 XNKT 06	25	3	150	25	40	0,572	KRLY.	₺1.152
S840	D26 d25 Z03 L150 XNKT 06	26	3	150	25	40	0,572		₺1.152
S841	D32 d32 Z04 L150 XNKT 06	32	4	150	32	40	0,941		₺1.269
S842	D40 d32 Z05 L130 XNKT 06	40	5	130	32	45	0,865		₺1.469

TC065-1 M3x7
 T8

KRLY ucuna uygundur.

XNKT 0805

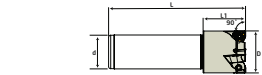
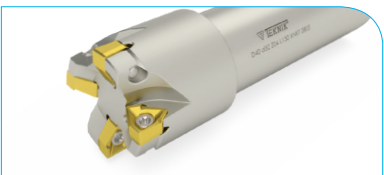

Sipariş Kodu	Ürün Kodu	Ölçüler (mm)						Uç	Fiyat
		D	Z	L	d	L1			
S843	D32 d32 Z03 L125 XNKT 08	32	3	125	32	37	0,817	XNKT 0805	₺1.170
S844	D40 d32 Z04 L130 XNKT 08	40	4	130	32	40	0,986	KRLY	₺1.258

TC072 M4x10
 T15

KRLY ucuna uygundur.

ANKX 1205

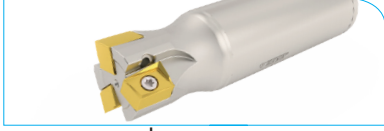

ISCR ucuna uygundur.

Sipariş Kodu	Ürün Kodu	Ölçüler (mm)						Uç	Fiyat
		D	Z	L	d	L1	kg		
S695	D32 d32 Z03 L120 ANKX 12	32	3	120	32	40	0,700	ANKX 1205 ISCR.	₺1.052

TC074 M4x10 T15

ANHX 1004 - 1206

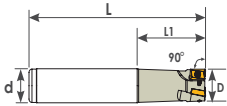

PLBT ucuna uygundur.

Sipariş Kodu	Ürün Kodu	Ölçüler (mm)						Uç	Fiyat
		D	Z	L	d	L1	kg		
S775	D16 d16 Z02 L090 ANHX 10	16	2	90	16	25	0,140		₺1.052
S776	D20 d20 Z02 L100 ANHX 10	20	2	100	20	30	0,247	ANHX 1004	₺1.052
S762	D25 d25 Z03 L115 ANHX 10	25	3	115	25	35	0,432	PLBT	₺1.232
S763	D32 d32 Z03 L125 ANHX 10	32	3	125	32	40	0,783		₺1.232
S782	D16 d16 Z02 L160 ANHX 10	16	2	160	16	25	0,036		₺1.385
S783	D20 d20 Z03 L160 ANHX 10	20	3	160	20	30	0,058		₺1.541
S784	D25 d25 Z03 L180 ANHX 10	25	3	180	25	35	0,099		₺1.541
S785	D32 d32 Z04 L150 ANHX 10	32	4	150	32	40	0,136		₺1.697
S764	D25 d25 Z02 L110 ANHX 12	25	2	110	25	35	0,405	ANHX 1206	₺1.032
S765	D32 d32 Z03 L150 ANHX 12	32	3	150	32	35	0,922	PLBT	₺1.232

Kod TC065 M3x7 T8 T10

S775-S785 TC065 M3x7 T8
S764-S765 TC069 M3,5x8,5 T10

LNGU 15T6



KNNMTL ucuna uygundur.

Sipariş Kodu	Ürün Kodu	Ölçüler (mm)						Uç	Fiyat
		D	Z	L	d	L1	kg		
S950	D25 d25 Z02 L150 LNGU 15	25	2	150	25	45	0,547	LNGU 15T6	₺1.152
S951	D32 d32 Z03 L150 LNGU 15	32	3	150	32	45	0,884	KNNMTL.	₺1.210

TC074 M4x10 T15

LNMX 1006

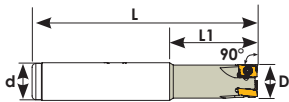

KRLY ucuna uygundur.

Sipariş Kodu	Ürün Kodu	Ölçüler (mm)						Uç	Fiyat
		D	Z	L	d	L1	kg		
LN096	D16 d16 Z01 L090 LNMX 10	16	1	90	16	25	0,140		₺878
LN097	D22 d20 Z02 L100 LNMX 10	22	2	100	20	-	0,263	LNMX 1006	₺950
LN098	D24 d25 Z03 L100 LNMX 10	24	3	100	25	15	0,389	KRLY.	₺993
LN099	D20 d20 Z02 L120 LNMX 10	20	2	120	20	25	0,292		₺950
LN100	D20 d20 Z03 L120 LNMX 10	20	3	120	20	25	0,285		₺1.110
LN102	D25 d25 Z03 L120 LNMX 10	25	3	120	25	40	0,453		₺1.110
LN103	D32 d32 Z04 L125 LNMX 10	32	4	125	32	40	0,706		₺1.346
LN104	D40 d32 Z05 L130 LNMX 10	40	5	130	32	42	0,857		₺1.521

TC065 M3x7 T8

LNMX 1510

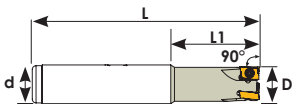
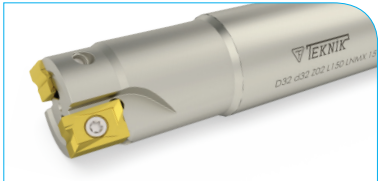

KRLY ucuna uygundur.

Sipariş Kodu	Ürün Kodu	Ölçüler (mm)						Uç	Fiyat
		D	Z	L	d	L1	kg		
S361	D32 d32 Z02 L150 LNMX 15	32	2	150	32	50	0,885	LNMX 1510	₺1.152
S362	D40 d32 Z03 L150 LNMX 15	40	3	150	32	50	0,966	KRLY.	₺1.210

TC076 M4x12,5 T15

WNGX 0403

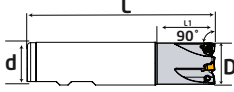

KRLY ucuna uygundur.

Sipariş Kodu	Ürün Kodu	Ölçüler (mm)						Uç	Fiyat
		D	Z	L	d	L1	kg		
S944	D20 d20 Z03 L110 WNGX 04	20	3	110	20	35	0,246	WNGX 0403	₺1.073
S945	D25 d25 Z04 L110 WNGX 04	25	4	110	25	35	0,380	KRLY	₺1.209
S946	D32 d32 Z05 L110 WNGX 04	32	5	110	32	35	0,642		₺1.385



TC060 M2,5x5,5



T8



XNEX 0403

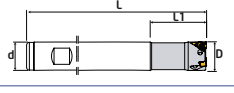
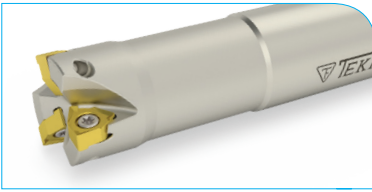

SCO ucuna uygundur.

Sipariş Kodu	Ürün Kodu	Ölçüler (mm)						Uç	Fiyat
		D	Z	L	d	L1	kg		
S195	D20 d20 Z03 L150 XNEX 04	20	3	150	20	40	0,344	XNEX 0403	₺1.131
S196	D21 d20 Z03 L150 XNEX 04	21	3	150	20	40	0,348	SCO	₺1.131
S198	D26 d25 Z04 L150 XNEX 04	26	4	150	25	40	0,535		₺1.268



TC061 M2,5x7



T8



WNGX 0806

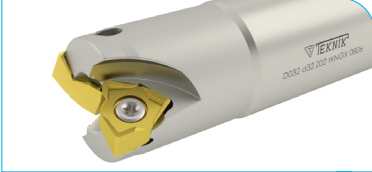

KRLY ucuna uygundur.

Sipariş Kodu	Ürün Kodu	Ölçüler (mm)						Uç	Fiyat
		D	Z	L	d	L1	kg		
S949	D40 d32 Z03 L120 WNGX 08	40	3	120	32	40	0,784	WNGX 0806 KRLY	₺1.209



TC083 M5X12



T20



LNMT 0804

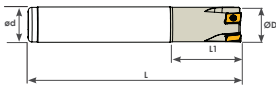

ISCR ucuna uygundur.

Sipariş Kodu	Ürün Kodu	Ölçüler (mm)						Uç	Fiyat
		D	Z	L	d	L1	kg		
S298	D16 d16 Z02 L120 LNMT 08	16	2	120	16	40	0,206		₺833
S299	D20 d20 Z03 L120 LNMT 08	20	3	120	20	40	0,313	LNMT 0804	₺1.032
S300	D25 d25 Z04 L120 LNMT 08	25	4	120	25	40	0,477	ISCR.	₺1.032
S300-1	D32 d32 Z05 L120 LNMT 08	32	5	120	32	40	0,775		₺1.191
S301	D16 d16 Z02 L150 LNMT 08	16	2	150	16	40	0,256		₺1.073
S302	D20 d20 Z03 L150 LNMT 08	20	3	150	20	40	0,391		₺1.152
S303	D25 d25 Z04 L150 LNMT 08	25	4	150	25	40	0,601		₺1.191
S303-1	D32 d32 Z05 L150 LNMT 08	32	5	150	32	40	0,978		₺1.310



TC061 M2,5x6,5



T8



WNMU 0403

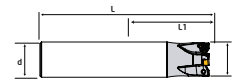
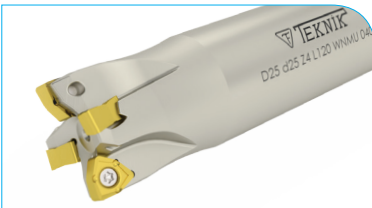

ISCR ucuna uygundur.

Sipariş Kodu	Ürün Kodu	Ölçüler (mm)						Uç	Fiyat
		D	Z	L	d	L1	kg		
S457	D20 d20 Z03 L120 WNMU 04	20	3	120	20	25	0,290	WNMU 0403	₺1.073
S458	D25 d25 Z04 L120 WNMU 04	25	4	120	25	30	0,466	ISCR	₺1.190
S459	D32 d32 Z04 L120 WNMU 04	32	4	120	32	35	0,776		₺1.248



TC060 M2,5x5,5



T8



LOEX 0804

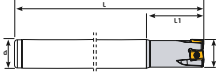

Sipariş Kodu	Ürün Kodu	Ölçüler (mm)							Uç	Fiyat
		D	Z	L	d	L1				
S295	D20 d20 Z03 L150 LOEX 08	20	3	150	20	40	0,384	LOEX 0804	₺993	
S296	D25 d25 Z04 L150 LOEX 08	25	4	150	25	40	0,604	SCO	₺1.073	

TC063 M2,5x7
 T8

SCO ucuna uygundur.

LNHU 0904

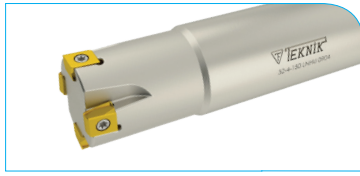

Sipariş Kodu	Ürün Kodu	Ölçüler (mm)							Uç	Fiyat
		D	Z	L	d	L1				
S328	D25 d25 Z03 L150 LNHU 09	25	3	150	25	40	0,599	LNHU 0904	₺1.152	
S329	D32 d32 Z04 L150 LNHU 09	32	4	150	32	40	0,972	WLTR.	₺1.191	

TC065-1 M3x7
 T8

WLTR ucuna uygundur.

LNMX 0603

NEW PRODUCT

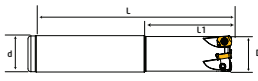
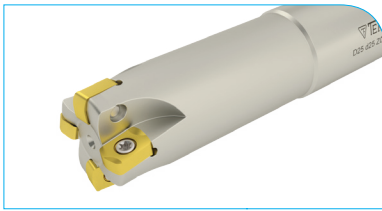

Sipariş Kodu	Ürün Kodu	Ölçüler (mm)							Uç	Fiyat
		D	Z	L	d	L1				
S284	D16 d16 Z02 L110 LNMX 06	16	2	110	16	30	0,172		₺1.053	
S285	D20 d20 Z03 L130 LNMX 06	20	3	130	20	50	0,325	LNMX 0603	₺1.131	
S286	D25 d25 Z04 L140 LNMX 06	25	4	140	25	60	0,552	KRLY	₺1.209	
S287	D32 d32 Z05 L150 LNMX 06	32	5	150	32	70	1,516		₺1.463	

TC065-1 M3x7
 T8

KRLY ucuna uygundur.

BLMP 0603

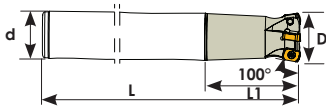

Sipariş Kodu	Ürün Kodu	Ölçüler (mm)							Uç	Fiyat
		D	Z	L	d	L1				
S479	D16 d16 Z02 L150 BLMP 06	16	2	150	16	40	0,235		₺1.073	
S478	D17 d16 Z02 L150 BLMP 06	17	2	150	16	40	0,244	BLMP 0603	₺1.073	
S481	D20 d20 Z03 L150 BLMP 06	20	3	150	20	40	0,335	TGTC.	₺1.151	
S483	D25 d20 Z04 L150 BLMP 06	25	4	150	20	30	0,280		₺1.209	
S480	D21 d20 Z03 L200 BLMP 06	21	3	200	20	40	0,520		₺1.174	
S482	D26 d25 Z04 L200 BLMP 06	26	4	200	25	40	0,771		₺1.232	

TC064 M3x6,5
 T8

TGTC ucuna uygundur. / Kompatible für TGTC WP

LOGU 0303

NEW PRODUCT

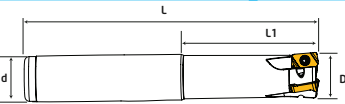
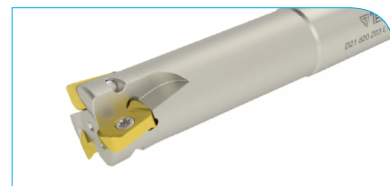

Sipariş Kodu	Ürün Kodu	Ölçüler (mm)							Uç	Fiyat
		D	Z	L	d	L1				
S677	D16 d16 Z02 L150 LOGU 03	16	2	150	16	50	0,219		₺1.073	
S678	D20 d20 Z03 L150 LOGU 03	20	3	150	20	60	0,356	LOGU 0303	₺1.151	
S679	D21 d20 Z03 L150 LOGU 03	21	3	150	20	60	0,365	KYCR	₺1.151	
S680	D25 d25 Z04 L150 LOGU 03	25	4	150	25	60	0,579		₺1.209	

TC064 M3x6
 T8

KYCR ucuna uygundur.

Sipariş Kodu	Ürün Kodu	Ölçüler (mm)						Uç	Fiyat
		D	Z	L	d	L1	kg		
S671	D16 d16 Z02 L150 LNMU 03	16	2	150	16	50	0,233		₺1.052
S672	D17 d16 Z02 L150 LNMU 03	17	2	150	16	40	0,241	LNMU 0303	₺1.052
S673	D20 d20 Z03 L150 LNMU 03	20	3	150	20	50	0,381	TNGLY - OKE	₺1.239
S674	D21 d20 Z03 L150 LNMU 03	21	3	150	20	50	0,389		₺1.239
S675	D25 d25 Z04 L150 LNMU 03	25	4	150	25	60	0,589		₺1.326

TC063 M2,5x7 T8

TNGLY - OKE ucuna uygundur.

Sipariş Kodu	Ürün Kodu	Ölçüler (mm)						Uç	Fiyat
		D	Z	L	d	L1	kg		
S105	D16 d16 Z02 L100 ENMX 06	16	2	100	16	30	0,146		₺1.053
S106	D16 d16 Z02 L150 ENMX 06	16	2	150	16	50	0,228	ENMX 0604	₺1.073
S107	D17 d16 Z02 L150 ENMX 06	17	2	150	16	20	0,242	YG1	₺1.073
S108	D20 d20 Z03 L130 ENMX 06	20	3	130	20	50	0,316		₺1.239
S109	D20 d20 Z03 L160 ENMX 06	20	3	160	20	80	0,382		₺1.268
S110	D21 d20 Z03 L150 ENMX 06	21	3	150	20	20	0,391		₺1.268
S111	D25 d25 Z04 L140 ENMX 06	25	4	140	25	60	0,538		₺1.346
S112	D25 d25 Z04 L180 ENMX 06	25	4	180	25	80	0,696		₺1.365
S113	D26 d25 Z04 L150 ENMX 06	26	4	150	25	30	0,612		₺1.346
S114	D32 d32 Z05 L150 ENMX 06	32	5	150	32	70	0,963		₺1.502
S115	D32 d32 Z05 L200 ENMX 06	32	5	200	32	70	0,963		₺1.580

TC063 M2,5x7 T8

YG1 ucuna uygundur.

Sipariş Kodu	Ürün Kodu	Ölçüler (mm)						Uç	Fiyat
		D	Z	L	d	L1	kg		
S934	D25 d25 Z02 L150 ENMX 09	25	2	150	25	70	0,576		₺1.073
S935	D32 d32 Z03 L160 ENMX 09	32	3	160	32	70	1,015	ENMX 0905	₺1.248
S936	D40 d32 Z05 L180 ENMX 09	40	5	180	32	40	1,308	YG1	₺1.424

TC069 M3,5x8,5 T15

YG1 ucuna uygundur.

Sipariş Kodu	Ürün Kodu	Ölçüler (mm)						Uç	Fiyat
		D	Z	L	d	L1	kg		
S395	D25 d25 Z02 L150 SDMT 09	25	2	150	25	60	0,573	SDMT 09T3	₺1.052
S396	D32 d32 Z03 L150 SDMT 09	32	3	150	32	60	0,934	ZCC	₺1.110

TC067 M3,5x8,5 T15

ZCC ucuna uygundur.

WNMX 0603

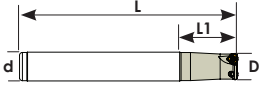

Sipariş Kodu	Ürün Kodu	Ölçüler (mm)							Uç	Fiyat
		D	Z	L	d	L1				
S898	D16 d16 Z02 L150 WNMX 06	16	2	150	16	40	0,241		₺1.052	
S899	D20 d20 Z02 L150 WNMX 06	20	2	150	20	40	0,378	WNMX 0603	₺1.052	
S903	D17 d16 Z02 L150 WNMX 06	17	2	150	16	40	0,240	KRLY.	₺1.191	
S904	D21 d20 Z02 L150 WNMX 06	21	2	150	20	40	0,379		₺1.191	
S905	D25 d25 Z03 L150 WNMX 06	25	3	150	25	60	0,578		₺1.232	
S906	D26 d25 Z04 L150 WNMX 06	26	4	150	25	60	0,582		₺1.310	

TC060 M2,5x5,5
 T8

KRLY ucuna uygundur.

WNMX 09T3

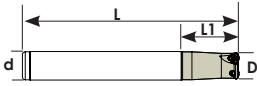

Sipariş Kodu	Ürün Kodu	Ölçüler (mm)							Uç	Fiyat
		D	Z	L	d	L1				
S802	D25 d25 Z02 L150 WNMX 09	25	2	150	25	60	0,563		₺1.052	
S803	D26 d25 Z02 L140 WNMX 09	26	2	140	25	60	0,477		₺1.052	
S804	D30 d25 Z03 L150 WNMX 09	30	3	150	25	60	0,590	WNMX 09T3	₺1.210	
S805	D32 d32 Z03 L150 WNMX 09	32	3	150	32	70	0,841	KRLY.	₺1.210	
S806	D33 d32 Z03 L150 WNMX 09	33	3	150	32	70	0,854		₺1.210	
S807	D40 d32 Z04 L150 WNMX 09	40	4	150	32	60	0,974		₺1.521	

TC065 M3x7
 T8

KRLY ucuna uygundur.

WNMX 1305

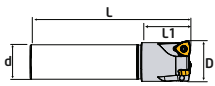

Sipariş Kodu	Ürün Kodu	Ölçüler (mm)							Uç	Fiyat
		D	Z	L	d	L1				
S800	D32 d32 Z02 L120 WNMX 13	32	2	120	32	70	0,933	WNMX 1305	₺1.092	
S801	D40 d32 Z03 L150 WNMX 13	40	3	150	32	50	1,069	KRLY	₺1.326	

TC074 M4x10
 T15

KRLY ucuna uygundur.

SPMG 0502 - 0602-07T3 0904

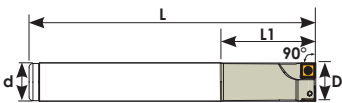
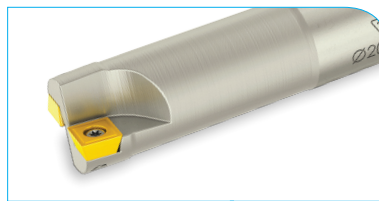



Sipariş Kodu	Ürün Kodu	Ölçüler (mm)							Uç	Fiyat
		D	Z	L	d	L1				
S810	D013 d14 Z02 L120 SPMG 05	13	2	120	14	40	0,147	SPMG 0502	₺736	
S812	D13,5 d14 Z02 L120 SPMG 05	13,5	2	120	14	40	0,149	TGTC	₺736	
S814	D014 d14 Z02 L120 SPMG 06	14	2	120	14	40	0,148	SPMG 0602	₺736	
S818	D015 d16 Z02 L120 SPMG 06	15	2	120	16	40	0,186	TGTC.	₺736	
S822	D016 d16 Z02 L120 SPMG 06	16	2	120	16	40	0,194		₺736	
S824	D020 d20 Z02 L150 SPMG 07	20	2	150	20	50	0,198	SPMG 07T3	₺872	
S826	D20,5 d20 Z02 L120 SPMG 07	20,5	2	120	20	50	0,290	TGTC.	₺775	
S828	D025 d25 Z02 L150 SPMG 09	25	2	150	25	50	0,567	SPMG 0904	₺935	
S830	D032 d32 Z03 L150 SPMG 09	32	3	150	32	40	0,908	TGTC	₺1.032	



Kod
 TC058 M2x4,2
 T6
 TC059 M2,2x5
 T7
 TC063 M2,5x7
 T8
 TC067 M3,5x8,5
 T15

TGTC ucuna uygundur. / Kompatible für TGTC WP

Sipariş Kodu	Ürün Kodu	Ölçüler (mm)							Uç	Fiyat
		D	Z	L	d	L1	kg			
S710	D25 d25 Z02 L150 VCGT 16	25	2	150	25	50	0,518		₺935	
S712	D32 d32 Z02 L150 VCGT 16	32	2	150	32	60	0,852	VCGT 1604	₺993	
S714	D40 d32 Z03 L150 VCGT 16	40	3	150	32	60	0,951	ISO.	₺1.032	
S718	D25 d25 Z02 L200 VCGT 16	25	2	200	25	60	0,730		₺1.014	
S720	D32 d32 Z02 L200 VCGT 16	32	2	200	32	60	1,225		₺1.052	
S724	D25 d25 Z02 L250 VCGT 16	25	2	250	25	60	0,920		₺1.269	
S726	D32 d32 Z02 L250 VCGT 16	32	2	250	32	60	1,250		₺1.347	







Sipariş Kodu	Ürün Kodu	Ölçüler (mm)							Uç	Fiyat
		D	Z	L	d	L1	kg			
S344	D32 d25 Z03 L100 APXT 10	32	3	100	25	35	0,413		₺814	
S346	D40 d25 Z04 L100 APXT 10	40	4	100	25	35	0,494	APXT 1003	₺872	
S348	D45 d25 Z04 L100 APXT 10	45	4	100	25	35	0,535	KRLY.	₺872	
S350	D50 d25 Z05 L100 APXT 10	50	5	100	25	35	0,583		₺1.032	





KRLY ucuna uygundur.

Sipariş Kodu	Ürün Kodu	Ölçüler (mm)						Uç	Fiyat
		D	L	d	L1	kg			
S370	D08 d10 L130 P32-08	8	130	10	36	0,092	P32 08 WLTR.	₺914	
S372	D10 d12 L130 P32-10	10	130	12	46	0,118	P32 10 WLTR.	₺914	
S374	D12 d12 L150 P32-12	12	150	12	46	0,142	P32 12 WLTR.	₺950	
S376	D16 d16 L175 P32-16	16	175	16	46	0,270	P32 16 WLTR.	₺993	
S378	D20 d20 L200 P32-20	20	200	20	56	0,505	P32 20 WLTR.	₺1.092	
S380	D25 d25 L200 P32-25	25	200	25	66	0,745	P32 25 WLTR.	₺1.152	
S381	D30 d32 L200 P32-30	30	200	32	66	1,148	P32 30 WLTR.	₺1.210	
S382	D32 d32 L200 P32-32	32	200	32	66	1,150	P32 32 WLTR.	₺1.210	



Kod |  | 

S370	TC170 M3	T8
S372	TC172 M4	T15
S374	TC174 M5	T20
S376	TC176 M5	T20
S378	TC178 M5	T20
S380	TC181 M6	3 Allen
S381-S382	TC184 M8	4 Allen



WLTR ucuna uygundur.

Sipariş Kodu	Ürün Kodu	Ölçüler (mm)							Uç	Fiyat
		D	Z	L	d	L1	kg			
S771	D20 d20 Z02 L160 RDMT 10	20	2	160	20	60	0,359	RDMT 1003	₺1.152	
S772	D20 d25 Z02 L220 RDMT 10	20	2	220	25	120	0,658	PLBT	₺1.152	
S773	D25 d25 Z02 L220 RDMT 12	25	2	220	25	120	0,741	RDMT 12T3	₺1.232	
S774	D25 d32 Z02 L230 RDMT 12	25	2	230	32	130	1,099	PLBT	₺1.232	

Kod |  | 

S771-S772	TC071 M3,5x7	T15
S773-S774	TC067 M3,5x8,5	



PLBT ucuna uygundur.

RDMW 0501

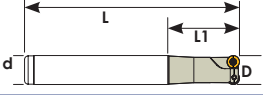
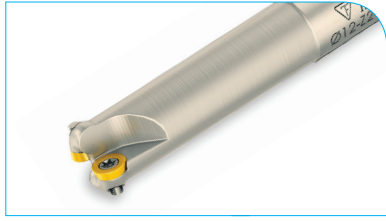

Sipariş Kodu	Ürün Kodu	Ölçüler (mm)						Uç	Fiyat
		D	Z	L	d	L1			
R080	D08 d10 Z01 L080 RDMW 05	8	1	80	10	27	0,053		₺794
R082	D10 d12 Z02 L080 RDMW 05	10	2	80	12	34	0,076	RDMW 0501	₺794
R083	D10 d12 Z02 L100 RDMW 05	10	2	100	12	40	0,085	TGTC.	₺793
R084	D10 d12 Z02 L120 RDMW 05	10	2	120	12	45	0,111		₺794
R086	D12 d12 Z02 L100 RDMW 05	12	2	100	12	40	0,099		₺794
R088	D12 d12 Z02 L120 RDMW 05	12	2	120	12	45	0,118		₺794



TGTC ucuna uygundur. / Kompatible für TGTC WP

RDMW 0702

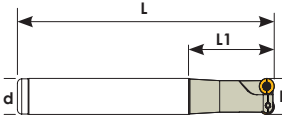
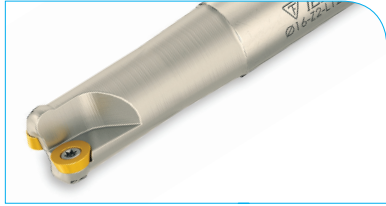

Sipariş Kodu	Ürün Kodu	Ölçüler (mm)						Uç	Fiyat
		D	Z	L	d	L1			
R136	D15 d16 Z02 L120 RDMW 07	15	2	120	16	40	0,187		₺833
R138	D16 d16 Z02 L120 RDMW 07	16	2	120	16	40	0,148	RDMW 0702	₺833
R142	D20 d20 Z03 L120 RDMW 07	20	3	120	20	45	0,278	TGTC.	₺872
R143	D15 d16 Z02 L150 RDMW 07	15	2	150	16	50	0,228		₺914
R144	D16 d16 Z02 L150 RDMW 07	16	2	150	16	60	0,230		₺914
R148	D20 d20 Z03 L150 RDMW 07	20	3	150	20	60	0,354		₺993



TGTC ucuna uygundur. / Kompatible für TGTC WP

RPMW 0803

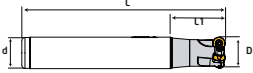
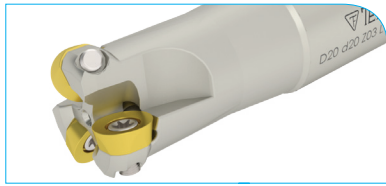

Sipariş Kodu	Ürün Kodu	Ölçüler (mm)						Uç	Fiyat
		D	Z	L	d	L1			
R310	D16 d16 Z02 L130 RPMW 08	16	2	130	16	35	0,198		₺917
R311	D18 d16 Z02 L150 RPMW 08	18	2	150	16	35	0,240	RPMW 0803	₺917
R312	D20 d20 Z03 L130 RPMW 08	20	3	130	20	35	0,316	KRLY	₺1.073
R313	D25 d25 Z04 L150 RPMW 08	25	4	150	25	35	0,591		₺1.209



KRLY ucuna uygundur.

RPMW 10T3

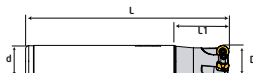
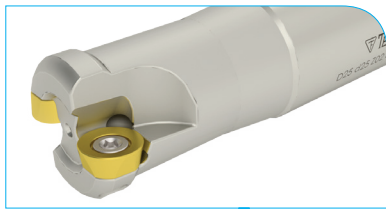

Sipariş Kodu	Ürün Kodu	Ölçüler (mm)						Uç	Fiyat
		D	Z	L	d	L1			
R316	D20 d20 Z02 L120 RPMW 10	20	2	120	20	40	0,282		₺894
R317	D25 d25 Z02 L120 RPMW 10	25	2	120	25	40	0,447	RPMW 10T3	₺894
R318	D25 d25 Z02 L160 RPMW 10	25	2	160	25	60	0,617	KRLY	₺1.073
R319	D32 d32 Z04 L125 RPMW 10	32	4	125	32	40	0,792		₺1.112
R320	D32 d25 Z04 L200 RPMW 10	32	4	200	25	60	0,891		₺1.307
R321	D40 d32 Z04 L150 RPMW 10	40	4	150	32	35	1,071		₺1.307

Kod



R316	TC071 M3,5x7
R317-R321	TC067 M3,5x8,5

T15

KRLY ucuna uygundur.

RPMW 1204

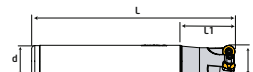
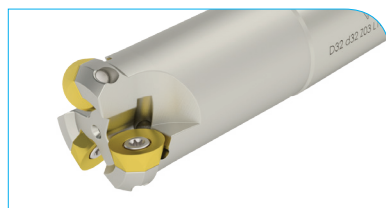

Sipariş Kodu	Ürün Kodu	Ölçüler (mm)						Uç	Fiyat
		D	Z	L	d	L1			
R325	D25 d25 Z02 L160 RPMW 12	25	2	160	25	60	0,607		₺1.112
R326	D32 d32 Z03 L160 RPMW 12	32	3	160	32	60	1,017	RPMW 1204	₺1.268
R327	D40 d32 Z04 L150 RPMW 12	40	4	150	32	35	1,056	KRLY	₺1.307



KRLY ucuna uygundur.

RDMT 1003

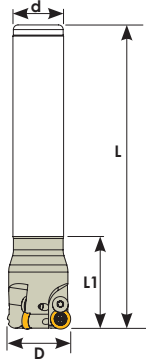
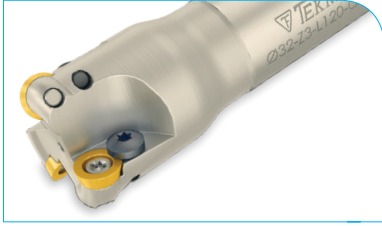

Sipariş Kodu	Ürün Kodu	Ölçüler (mm)						Uç	Fiyat
		D	Z	L	d	L1			
R190	D20 d20 Z02 L120 RDMT 10	20	2	120	20	55	0,265		₺892
R192	D25 d25 Z02 L120 RDMT 10	25	2	120	25	50	0,435		₺892
R193	D30 d25 Z03 L120 RDMT 10	30	3	120	25	40	0,468		₺1.032
R194	D32 d25 Z03 L120 RDMT 10	32	3	120	25	40	0,484		₺1.032
R196	D35 d25 Z03 L120 RDMT 10	35	3	120	25	45	0,508	RDMT 1003	₺1.032
R198	D40 d25 Z04 L120 RDMT 10	40	4	120	25	45	0,558	ISO.	₺1.092
R200	D20 d20 Z02 L150 RDMT 10	20	2	150	20	60	0,336		₺1.073
R202	D25 d25 Z02 L150 RDMT 10	25	2	150	25	60	0,544		₺1.073
R203	D30 d25 Z03 L150 RDMT 10	30	3	150	25	40	0,586		₺1.131
R204	D32 d32 Z03 L150 RDMT 10	32	3	150	32	45	0,898		₺1.131
R206	D35 d32 Z03 L150 RDMT 10	35	3	150	32	45	0,923		₺1.131
R208	D40 d32 Z04 L150 RDMT 10	40	4	150	32	45	0,967		₺1.210
R210	D20 d20 Z02 L200 RDMT 10	20	2	200	20	80	0,477		₺1.152
R212	D25 d25 Z02 L200 RDMT 10	25	2	200	25	70	0,747		₺1.152
R213	D30 d25 Z03 L200 RDMT 10	30	3	200	25	40	0,789		₺1.210
R214	D32 d32 Z03 L200 RDMT 10	32	3	200	32	45	1,273		₺1.210
R216	D35 d32 Z03 L200 RDMT 10	35	3	200	32	45	1,227		₺1.210
R218	D40 d32 Z04 L200 RDMT 10	40	4	200	32	45	1,281		₺1.291

Kod				
R190	TC071 M3,5x7	TC040 M3,5		
R192-R218	TC067 M3,5x8,5	TC040 M3,5		

RDMT 12T3

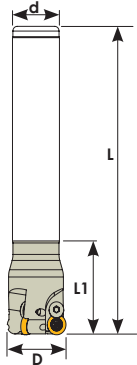
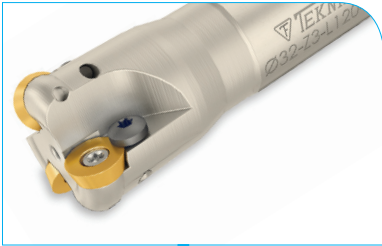

Sipariş Kodu	Ürün Kodu	Ölçüler (mm)						Uç	Fiyat
		D	Z	L	d	L1			
R228	D25 d25 Z02 L120 RDMT 12	25	2	120	25	50	0,422		₺892
R229	D30 d25 Z02 L120 RDMT 12	30	2	120	25	40	0,456		₺892
R230	D32 d25 Z03 L120 RDMT 12	32	3	120	25	40	0,473		₺1.032
R232	D35 d25 Z03 L120 RDMT 12	35	3	120	25	40	0,485		₺1.032
R234	D40 d25 Z03 L120 RDMT 12	40	3	120	25	40	0,513	RDMT 12T3	₺1.032
R236	D25 d25 Z02 L150 RDMT 12	25	2	150	25	60	0,539	ISO.	₺1.073
R237	D30 d25 Z02 L150 RDMT 12	30	2	150	25	55	0,536		₺1.073
R238	D32 d32 Z03 L150 RDMT 12	32	3	150	32	45	0,876		₺1.131
R240	D35 d32 Z03 L150 RDMT 12	35	3	150	32	45	0,900		₺1.131
R242	D40 d32 Z03 L150 RDMT 12	40	3	150	32	45	0,956		₺1.131
R244	D25 d25 Z02 L200 RDMT 12	25	2	200	25	70	0,740		₺1.152
R245	D30 d25 Z02 L200 RDMT 12	30	2	200	25	55	0,784		₺1.152
R246	D32 d32 Z03 L200 RDMT 12	32	3	200	32	45	1,201		₺1.210
R248	D35 d32 Z03 L200 RDMT 12	35	3	200	32	45	1,226		₺1.210
R250	D40 d32 Z03 L200 RDMT 12	40	3	200	32	45	1,287		₺1.210
R255	D30 d25 Z02 L300 RDMT 12	30	2	300	25	55	1,168		₺1.469
R256	D32 d32 Z03 L300 RDMT 12	32	3	300	32	70	1,829		₺1.629
R258	D35 d32 Z03 L300 RDMT 12	35	3	300	32	45	1,855		₺1.629
R260	D40 d32 Z03 L300 RDMT 12	40	3	300	32	45	1,995		₺1.665

Kod				
	TC067 M3,5x8,5	T15	TC040 M3,5	

TPKN 1103-1603-2204

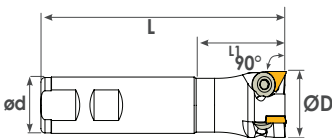
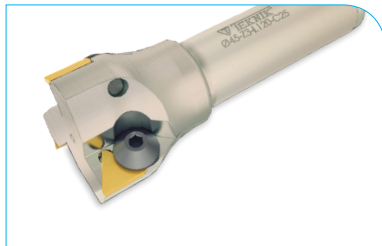

Sipariş Kodu	Ürün Kodu	Ölçüler (mm)						Uç	Fiyat
		D	Z	L	d	L1			
S116	D22 d20 Z02 L120 TPKN 11	22	2	120	20	45	0,301		₺714
S118	D25 d25 Z02 L120 TPKN 11	25	2	120	25	45	0,438	TPKN 1103	₺714
S124	D32 d25 Z03 L120 TPKN 11	32	3	120	25	45	0,480	ISO	₺775
S128	D35 d25 Z02 L120 TPKN 16	35	2	120	25	45	0,507	TPKN 1603	₺794
S130	D40 d25 Z03 L120 TPKN 16	40	3	120	25	45	0,552	ISO	₺872
S132	D45 d25 Z03 L120 TPKN 16	45	3	120	25	45	0,606		₺914
S134	D50 d32 Z03 L120 TPKN 22	50	3	120	32	55	0,896	TPKN 2204 ISO	₺993

Kod			
S116-S124	TC050 M6x14	3 Allen	
S128-S132	TC052 M6x17	4 Allen	
S134	TC054 M8x24	5 Allen	

Kalite için TEKNİK çözüm
Technical solution for quality

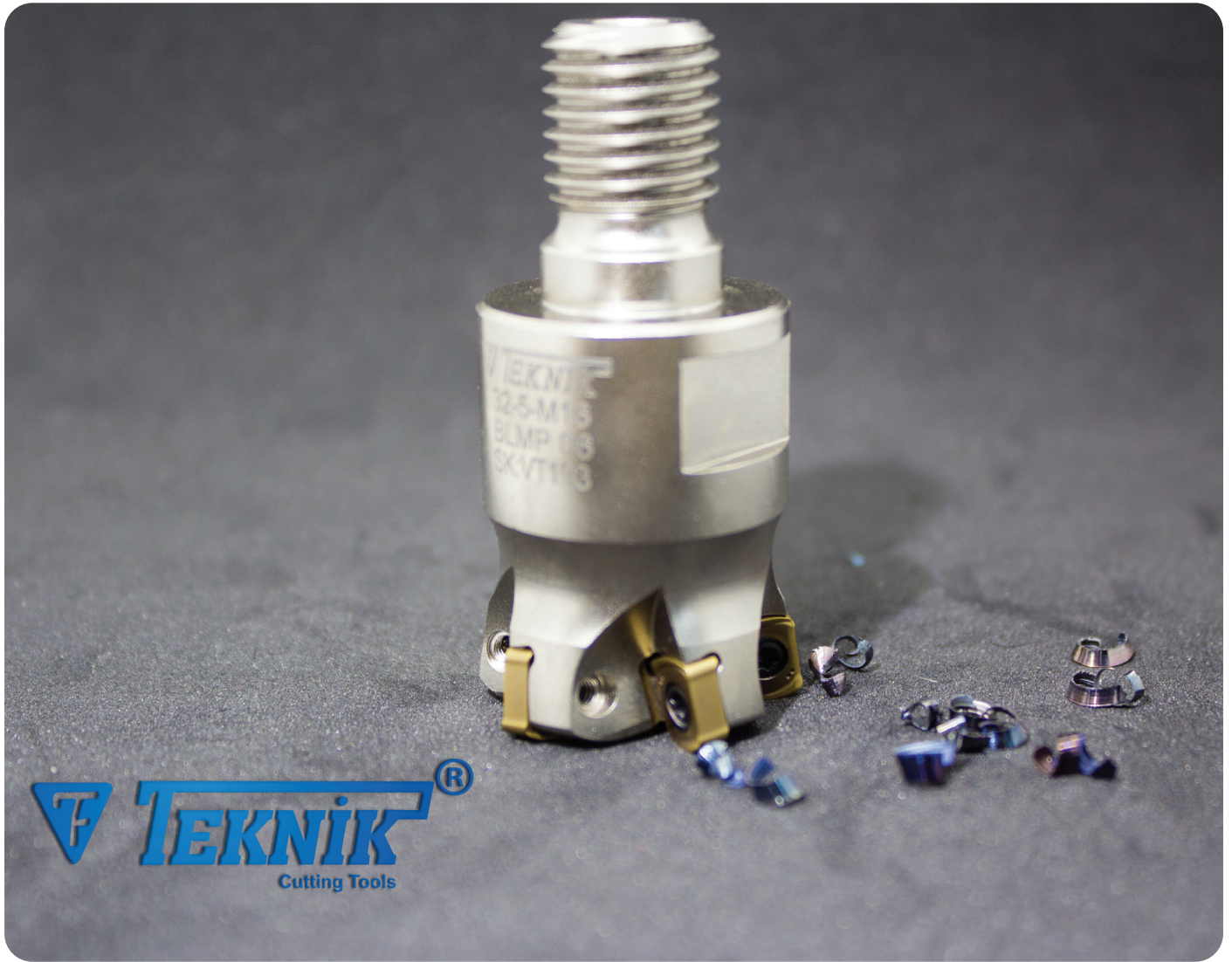

Vidalı Takım



www.teknikcuttingtools.com



Kalite için TEKNİK çözüm

Technical solution for quality

58-61

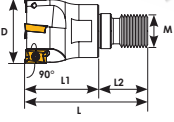
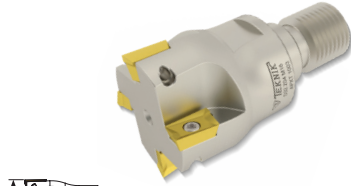

APXT 1003

Sipariş Kodu	Ürün Kodu	Ölçüler (mm)							Uç	Fiyat
		D	Z	M	L	L1	L2			
VT136	D16 Z02 M08 APXT 10	16	2	M08	41	25	16	0,050		₺950
VT138	D20 Z03 M10 APXT 10	20	3	M10	55	35	20	0,097	APXT 1003	₺1.032
VT140	D25 Z03 M12 APXT 10	25	3	M12	55	33	22	0,135	KRLY.	₺1.032
VT143	D32 Z04 M16 APXT 10	32	4	M16	60	36	24,5	0,195		₺1.092
VT146	D35 Z04 M16 APXT 10	35	4	M16	60	36	24,5	0,225		₺1.092
VT148	D40 Z05 M16 APXT 10	40	5	M16	60	36	24,5	0,266		₺1.210
VT150	D42 Z05 M16 APXT 10	42	5	M16	60	36	24,5	0,294		₺1.210

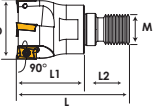
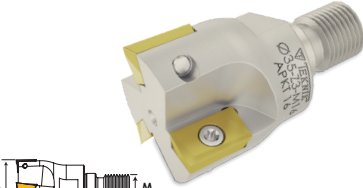

KRLY ucuna uygundur.

APKT 1604

Sipariş Kodu	Ürün Kodu	Ölçüler (mm)							Uç	Fiyat
		D	Z	M	L	L1	L2			
VT160	D25 Z02 M12 APKT 16	25	2	M12	55	33	22	0,107		₺950
VT163	D32 Z03 M16 APKT 16	32	3	M16	60	24	24,5	0,180	APKT 1604	₺1.032
VT166	D35 Z03 M16 APKT 16	35	3	M16	60	24	24,5	0,211	KRLY.	₺1.032
VT168	D40 Z04 M16 APKT 16	40	4	M16	60	24	24,5	0,238		₺1.092
VT170	D42 Z04 M16 APKT 16	42	4	M16	60	24	24,5	0,251		₺1.092

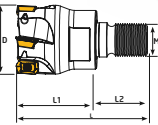
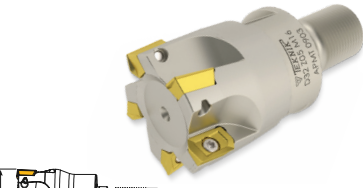

KRLY ucuna uygundur.

APMT 0903

Sipariş Kodu	Ürün Kodu	Ölçüler (mm)							Uç	Fiyat
		D	Z	M	L	L1	L2			
VT224	D16 Z02 M08 APMT 09	16	2	M08	41	25	16	0,040		₺950
VT225	D20 Z03 M10 APMT 09	20	3	M10	48	30	18	0,071	APMT 0903	₺1.032
VT226	D25 Z04 M12 APMT 09	25	4	M12	57	35	22	0,116	KRLY.	₺1.092
VT227	D32 Z05 M16 APMT 09	32	5	M16	65,3	40	25,3	0,229		₺1.210
VT228	D35 Z05 M16 APMT 09	35	5	M16	65,3	40	25,3	0,261		₺1.210
VT229	D40 Z06 M16 APMT 09	40	6	M16	65,3	40	25,3	0,299		₺1.429

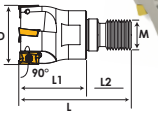

KRLY ucuna uygundur.

ADMX 0702

Sipariş Kodu	Ürün Kodu	Ölçüler (mm)							Uç	Fiyat
		D	Z	M	L	L1	L2			
VT200	D16 Z04 M08 ADMX 07	16	4	M08	41	23	18	0,041	ADMX 0702	₺1.092
VT201	D20 Z05 M10 ADMX 07	20	5	M10	49	30	19	0,080	PRMT.	₺1.210
VT203	D32 Z08 M16 ADMX 07	32	8	M16	66	43	23	0,235		₺1.528

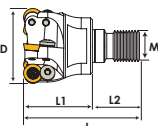

PRMT ucuna uygundur.

RDMT 1003

Sipariş Kodu	Ürün Kodu	Ölçüler (mm)							Uç	Fiyat
		D	Z	M	L	L1	L2			
VT098	D20 Z02 M10 RDMT 10	20	2	M10	55	35	20	0,087		₺950
VT100	D25 Z03 M12 RDMT 10	25	3	M12	55	33	22	0,114	RDMT 1003	₺1.032
VT103	D32 Z03 M16 RDMT 10	32	3	M16	60	35,5	24,5	0,188	ISO.	₺1.032
VT106	D35 Z04 M16 RDMT 10	35	4	M16	60	35,5	24,5	0,201		₺1.092
VT107	D35 Z05 M16 RDMT 10	35	5	M16	60	35,5	24,5	0,211		₺1.210
VT108	D40 Z05 M16 RDMT 10	40	5	M16	60	35,5	24,5	0,241		₺1.210
VT110	D42 Z05 M16 RDMT 10	42	5	M16	60	35,5	24,5	0,265		₺1.210

Kod

 VT098 TC071 M3,5x7
 VT100-VT110 TC067 M3,5x8,5

TC040 M3,5

T15



RDMT 12T3

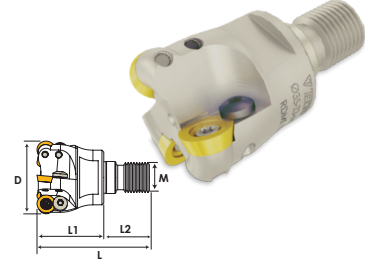

Sipariş Kodu	Ürün Kodu	Ölçüler (mm)							Uç	Fiyat
		D	Z	M	L	L1	L2	kg		
VT120	D25 Z02 M12 RDMT 12	25	2	M12	55	33	22	0,106		₺950
VT123	D32 Z03 M16 RDMT 12	32	3	M16	60	35,5	24,5	0,177	RDMT 12T3	₺1.032
VT126	D35 Z03 M16 RDMT 12	35	3	M16	60	35,5	24,5	0,196	ISO.	₺1.032
VT128	D40 Z04 M16 RDMT 12	40	4	M16	60	35,5	24,5	0,230		₺1.092
VT130	D42 Z04 M16 RDMT 12	42	4	M16	60	35,5	24,5	0,237		₺1.092

TC067 M3,5x8,5
 TC040 M3,5
 T15

RPMT 10

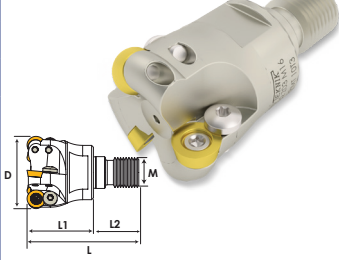

Sipariş Kodu	Ürün Kodu	Ölçüler (mm)							Uç	Fiyat
		D	Z	M	L	L1	L2	kg		
VT180	D25 Z03 M12 RPMT 10	25	3	M12	55	33	22	0,084	RPMT 10	₺1.032
VT182	D32 Z03 M16 RPMT 10	32	3	M16	68	36	24,5	0,189	MTSBSH.	₺1.032

TC067 M3,5x8,5
 TC040 M3,5
 T15

MTSBSH ucuna uygundur.

RPMT 12

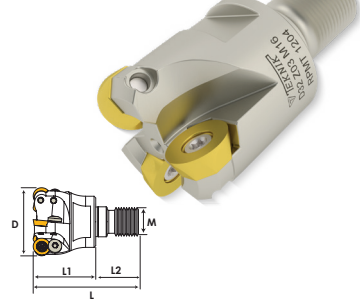

Sipariş Kodu	Ürün Kodu	Ölçüler (mm)							Uç	Fiyat
		D	Z	M	L	L1	L2	kg		
VT174	D25 Z02 M12 RPMT 12	25	2	M12	55	33	22	0,109	RPMT 12	₺950
VT176	D32 Z03 M16 RPMT 12	32	3	M16	60	34,7	25,3	0,164	MTSBSH.	₺1.032

TC067 M3,5x9
 T15

MTSBSH ucuna uygundur.

XNEX 0403

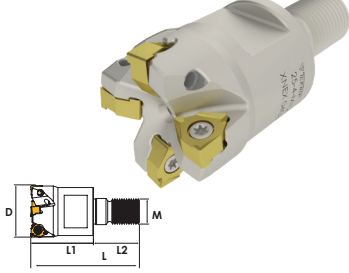

Sipariş Kodu	Ürün Kodu	Ölçüler (mm)							Uç	Fiyat
		D	Z	M	L	L1	L2	kg		
VT245	D20 Z03 M10 XNEX 04	20	3	M10	46	28	18	0,073		₺1.092
VT247	D25 Z04 M12 XNEX 04	25	4	M12	52	30	22	0,115	XNEX 0403	₺1.191
VT249	D32 Z05 M16 XNEX 04	32	5	M16	65	40	25	0,253	SCO	₺1.469

TC061 M2,5x7
 T8

SCO ucuna uygundur.

EPMT 0603

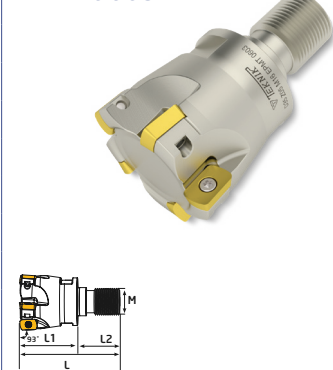

Sipariş Kodu	Ürün Kodu	Ölçüler (mm)							Uç	Fiyat
		D	Z	M	L	L1	L2	kg		
VT230	D16 Z02 M08 EPMT 06	16	2	M08	41	16	25	0,040		₺950
VT231	D20 Z03 M10 EPMT 06	20	3	M10	48	18	30	0,070		₺1.032
VT232	D25 Z04 M12 EPMT 06	25	4	M12	55	20	35	0,110	EPMT 0603	₺1.092
VT233	D32 Z05 M16 EPMT 06	32	5	M16	60	25,3	34,7	0,197	HTCH.	₺1.210
VT234	D35 Z05 M16 EPMT 06	35	5	M16	60	25,3	34,7	0,224		₺1.210
VT235	D40 Z06 M16 EPMT 06	40	6	M16	60	25,3	34,7	0,256		₺1.429
VT236	D42 Z06 M16 EPMT 06	42	6	M16	65,3	25,3	40	0,300		₺1.429

TC060 M2,5x5
 T7

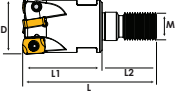

HTCH ucuna uygundur.

LNMX 0603



KRLY ucuna uygundur.

Sipariş Kodu	Ürün Kodu	Ölçüler (mm)							Uç	Fiyat
		D	Z	M	L	L1	L2	kg		
VT152	D16 Z02 M08 LNMX 06	16	2	M08	42	25	17	0,031		₺875
VT153	D20 Z03 M10 LNMX 06	20	3	M10	51	30	21	0,060	LNMX 0603	₺1.032
VT154	D25 Z04 M12 LNMX 06	25	4	M12	59	35	24	0,120	KRLY	₺1.092
VT155	D32 Z05 M16 LNMX 06	32	5	M16	67	40	27	0,227		₺1.210

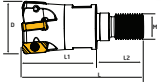

 TC065-1M3x7
  T8
 

LNMU 0303



TNGLY-OKE ucuna uygundur.

Sipariş Kodu	Ürün Kodu	Ölçüler (mm)							Uç	Fiyat
		D	Z	M	L	L1	L2	kg		
VT300	D16 Z02 M08 LNMU 03	16	2	M08	42	25	17	0,029		₺875
VT302	D20 Z03 M10 LNMU 03	20	3	M10	49	30	19	0,061	LNMU 0303	₺1.032
VT304	D25 Z04 M12 LNMU 03	25	4	M12	57	35	22	0,108	TNGLY-OKE	₺1.092
VT305	D32 Z05 M16 LNMU 03	32	5	M16	63	40	23	0,227		₺1.210
VT307	D40 Z06 M16 LNMU 03	40	6	M16	63	40	23	0,272		₺1.430

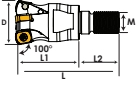

 TC065 M2,5x7
  T8
 

BLMP 0603



TGTC ucuna uygundur.

Sipariş Kodu	Ürün Kodu	Ölçüler (mm)							Uç	Fiyat
		D	Z	M	L	L1	L2	kg		
VT190	D16 Z02 M08 BLMP 06	16	2	M08	41	25	16	0,044		₺950
VT191	D20 Z03 M10 BLMP 06	20	3	M10	48	30	18	0,081	BLMP 0603	₺1.032
VT192	D25 Z04 M12 BLMP 06	25	4	M12	57	35	22	0,119	TGTC.	₺1.092
VT193	D32 Z05 M16 BLMP 06	32	5	M16	65	40	25	0,233		₺1.210
VT194	D35 Z05 M16 BLMP 06	35	5	M16	65	40	25	0,240		₺1.210
VT195	D40 Z06 M16 BLMP 06	40	6	M16	68	43	25	0,291		₺1.429
VT196	D42 Z06 M16 BLMP 06	42	6	M16	68	43	25	0,313		₺1.429

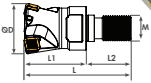

 TC064 M3x6,5
  T8
 

SDMT 09T3



ZCC ucuna uygundur.

Sipariş Kodu	Ürün Kodu	Ölçüler (mm)							Uç	Fiyat
		D	Z	M	L	L1	L2	kg		
VT240	D32 Z03 M16 SDMT 09	32	3	M16	69	40	29	0,211	SDMT 09T3	₺1.032
VT241	D35 Z03 M16 SDMT 09	35	3	M16	69	40	29	0,231	ZCC.	₺1.032
VT242	D40 Z04 M16 SDMT 09	40	3	M16	69	40	29	0,253		₺1.032

 TC067 M3,5x8,5
  T15
 

Vidalı Takım Tutucu

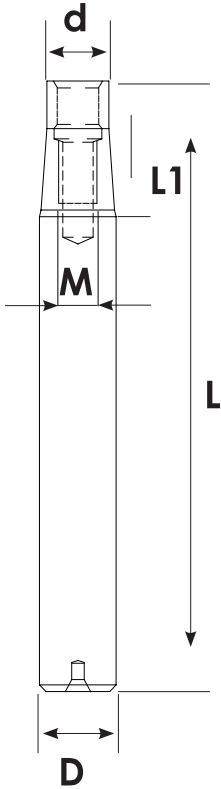

Sipariş Kodu	Ürün Kodu	Ölçüler (mm)							Fiyat
		D	d	L	L1	M			
VT500	D15 d12 L150 M8	15	12,7	150	30	M8	0,208	₺892	
VT501	D15 d12 L150 M8-IC	15	12,7	150	30	M8	0,202	₺935	
VT502	D16 d14 L100 M8	16	14	100	30	M8	0,153	₺833	
VT503	D16 d14 L100 M8-IC	16	14	100	30	M8	0,150	₺872	
VT504	D16 d14 L150 M8	16	14	150	30	M8	0,234	₺892	
VT505	D16 d14 L150 M8-IC	16	14	150	30	M8	0,230	₺935	
VT506	D19 d17 L150 M10	19	17,7	150	30	M10	0,329	₺892	
VT507	D19 d17 L150 M10-IC	19	17,7	150	30	M10	0,324	₺935	
VT508	D20 d17 L100 M10	20	17,7	100	30	M10	0,238	₺833	
VT509	D20 d17 L100 M10-IC	20	17,7	100	30	M10	0,235	₺872	
VT510	D20 d17 L150 M10	20	17,7	150	40	M10	0,357	₺892	
VT511	D20 d17 L150 M10-IC	20	17,7	150	40	M10	0,354	₺935	
VT512	D24 d20 L150 M12	24	20,7	150	40	M12	0,508	₺974	
VT513	D24 d20 L150 M12-IC	24	20,7	150	40	M12	0,502	₺1.032	
VT514	D25 d20 L150 M12	25	20,7	150	40	M12	0,546	₺974	
VT515	D25 d20 L150 M12-IC	25	20,7	150	40	M12	0,542	₺1.032	
VT516	D25 d20 L200 M12	25	20,7	200	40	M12	0,680	₺1.032	
VT517	D25 d20 L200 M12-IC	25	20,7	200	40	M12	0,675	₺1.092	
VT518	D25 d20 L250 M12	25	20,7	250	40	M12	0,700	₺1.152	
VT519	D25 d20 L250 M12-IC	25	20,7	250	40	M12	0,695	₺1.210	
VT520	D32 d28 L170 M16	32	28,7	170	40	M16	0,790	₺1.052	
VT521	D32 d28 L170 M16-IC	32	28,7	170	40	M16	0,784	₺1.110	
VT522	D32 d28 L220 M16	32	28,7	220	40	M16	0,860	₺1.232	
VT523	D32 d28 L220 M16-IC	32	28,7	220	40	M16	0,854	₺1.291	
VT524	D32 d28 L300 M16	32	28,7	300	40	M16	1,380	₺1.347	
VT525	D32 d28 L300 M16 -IC	32	28,7	300	40	M16	1,375	₺1.411	

İK İşten Su Vermelidir.

Kalite için TEKNİK çözüm
Technical solution for quality



Diş Katerleri



www.teknikcuttingtools.com



Kalite için TEKNIK çözüm
Technical solution for quality

64-68



Diş Çap Diş Katerleri/R

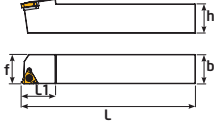

Sipariş Kodu	Ürün Kodu	Ölçüler (mm)						Uç	Fiyat
		L	L1	h	f	b	kg		
D261	AL 1212 J16- ER16	12	12	16	110	20	0,140		₺517
D259	AL 1616 H16- ER16	16	16	16	100	22	0,250	16 ER	₺517
D258	AL 2020 K16- ER16	20	20	20	125	25	0,410		₺541
D260	AL 2525 M16- ER16	25	25	25	150	30	0,750		₺580
D262	AL 3232 P16- ER16	32	32	32	170	30	1,430		₺703
D266	AL 2525 M22- ER22	25	25	25	150	30	0,740	22 ER	₺580
Kod									
D261-D262		TC068 M3,5x11	TA040	TC048 M5	T15				
D266		TC078 M4x11	--	--					

Diş Çap Diş Katerleri/L

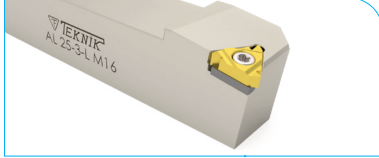

Sipariş Kodu	Ürün Kodu	Ölçüler (mm)						Uç	Fiyat
		L	L1	h	f	b	kg		
D268	AL 2020 K16 - L IR16	20	20	20	125	25	0,410		₺541
D269	AL 2525 M16 - L IR16	25	25	25	150	30	0,754	16 IR	₺580
D266-1	AL 2525 M22 - L IR22	25	25	25	150	30	0,748	22 IR	₺580
Kod									
D268-D269		TC068 M3,5x11	TA040	TC048 M5	T15				
D266-1		TC078 M4x11	--	--					

İç Çap Diş Katerleri/R

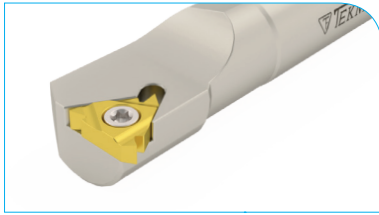

Sipariş Kodu	Ürün Kodu	Ölçüler (mm)					Delik Çapı	kg	Uç	Fiyat
		D	L	L1	f	Dmin				
K348	S10J STIR- IR11	10	110	20	6	12	0,079		₺408	
K350	S12K STIR- IR11	12	125	25	7,2	14	0,117	11 IR	₺415	
K352	S16Q STIR- IR16	16	180	40	11	20	0,286		₺495	
K354	S20Q STIR- IR16	20	180	40	13	25	0,436	16 IR	₺517	
K356	S25R STIR- IR16	25	200	40	16	29	0,762		₺637	
K358	S32T STIR- IR16	32	300	60	19,5	36	1,829		₺975	
K358-1	S20Q STIR- IR22	20	180	40	14	24	0,431		₺517	
K359	S25R STIR- IR22	25	200	40	17	32	0,757	22 IR	₺637	
K360	S32T STIR- IR22	32	300	60	19,5	36	1,818		₺975	
K360-1	S40T STIR- IR22	40	300	60	24,5	45	2,831		₺1.430	
Kod										
K348-K350		TC060 M2,5x5,5			T8					
K352-K358		TC067 M3,5x8,5			T10					
K358-1-K360-1		TC078 M4x11			T15					

İç Çap Diş Katerleri/L

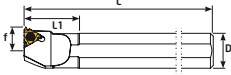
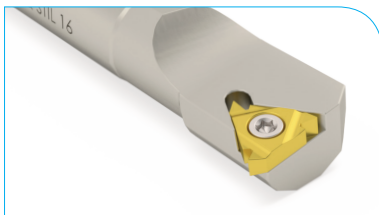

Sipariş Kodu	Ürün Kodu	Ölçüler (mm)					Delik Çapı	kg	Uç	Fiyat
		D	L	L1	f	Dmin				
K360-2	S10J STIL-ER11	10	110	20	6	12	0,079	11 ER	₺408	
K361	S16Q STIL-ER16	16	180	40	11	20	0,286		₺495	
K362	S20Q STIL-ER16	20	180	40	13	25	0,436	16 ER	₺517	
K363	S25R STIL-ER16	25	200	40	16	29	0,762		₺637	
Kod										
K360-2		TC060 M2,5x5,5			T8					
K361-K363		TC067 M3,5x8,5			T10					

Diş Çap Diş Katerleri/R

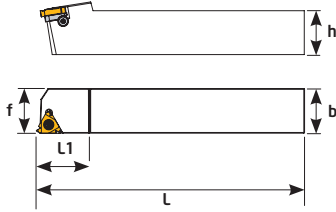
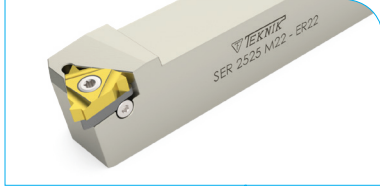

Sipariş Kodu	Ürün Kodu	Ölçüler (mm)						Uç	Fiyat
		h	b	f	L	L1	kg		
D494	SER 0808 H11 - ER11	8	8	11	100	20	0,061		₺605
D495	SER 1010 H11 - ER11	10	10	11	100	20	0,091	11 ER	₺605
D496	SER 1010 M11 - ER11	10	10	11	150	20	0,136		₺634
D497	SER 1212 K11 - ER11	12	12	12	125	20	0,160		₺615
D498	SER 1212 M11 - ER11	12	12	12	150	20	0,193		₺634
D500	SER 1212 J16 - ER16	12	12	16	110	22	0,110		₺580
D501	SER 1616 H16 - ER16	16	16	16	100	25	0,220		₺580
D502	SER 2020 K16 - ER16	20	20	20	125	30	0,410	16 ER	₺602
D503	SER 2525 M16 - ER16	25	25	25	150	30	0,750		₺644
D504	SER 3232 P16 - ER16	32	32	32	170	30	1,410		₺767
D505	SER 2525 M22 - ER22	25	25	25	150	30	0,740		₺703
D506	SER 3232 P22 - ER22	32	32	32	170	30	1,430	22 ER	₺810
D507	SER 4040 R22 - ER22	40	40	40	200	36	1,396		₺1.395
D491	SER 2525 M27 - ER27	25	25	32	150	36	2,585		₺1.268
D492	SER 3232 P27 - ER27	32	32	32	170	40	0,791	27 ER	₺1.317
D493	SER 4040 R27 - ER27	40	40	40	200	40	1,405		₺1.521

Kod	TC060 M2,5x5,5	TA061	TA060	TC062 M3	T8
D494-D498	TC060 M2,5x5,5	TA061	TA060	TC062 M3	T8
D500-D504	TC068 M3,5x11	TA062	TA060	TC062 M3	T15
D505-D507	TC077 M4x15	TA062	TA060	TC062 M3	T15
D491-D493	TC086 M5x18	TA064	TA060	TC053 M4	T20

Diş Çap Diş Katerleri/L

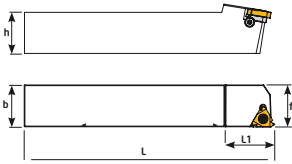
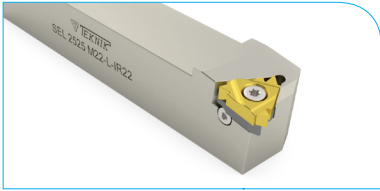



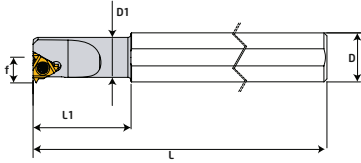
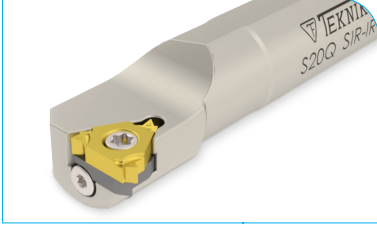

Sipariş Kodu	Ürün Kodu	Ölçüler (mm)						Uç	Fiyat
		h	b	f	L	L1	kg		
D508	SEL 1212 J16 -L- IR16	12	12	16	110	22	0,119		₺580
D509	SEL 1616H16 -L- IR16	16	16	16	100	25	0,223		₺580
D510	SEL 2020 K16 -L- IR16	20	20	20	125	30	0,414	16 IR	₺602
D511	SEL 2525 M16 -L- IR16	25	25	25	150	30	0,753		₺644
D512	SEL 3232 P16 -L- IR16	32	32	32	170	30	1,417		₺767
D513	SEL 2525 M22 -L- IR22	25	25	25	150	30	0,749	22 IR	₺703
D515	SEL 3232 P22 -L- IR22	32	32	32	170	36	1,434		₺810

Kod	TC068 M3,5x11	TA060	BSP010	TC062 M3	T15
D508-D512	TC068 M3,5x11	TA060	BSP010	TC062 M3	T15
D513-D515	TC077 M4x15	TA063	BSP010	TC062 M3	T15

İç Çap Diş Katerleri/R



Sipariş Kodu	Ürün Kodu	Ölçüler (mm)					Delik Çapı	kg	Uç	Fiyat
		D	D1	L	L1	f				
K337-1	SIR S12H - IR06	12	5,1	100	12	4,3	6	0,089	6 IR	₺517
K337-2	SIR S16K - IR08	16	6,6	125	18	5,3	7,8	0,195	8 IR	₺517
K337-3	SIR S10H - IR11	10	-	100	20	7,4	12	0,063		₺488
K337-4	SIR S16K - IR11	16	10	125	25	7,4	12	0,167	11 IR	₺517
K337-5	SIR S16L - IR11	16	13	140	32	8,9	15	0,207		₺517
K337-6	SIR S16M - IR16	16	13	150	32	10,2	16	0,221		₺517
K337-7	SIR S20P - IR16	20	16	170	40	11,7	19	0,381		₺563
K338	SIR S20Q - IR16	20	-	180	40	13,4	24	0,440	16 IR	₺563
K339	SIR S25R - IR16	25	-	200	45	16,1	29	0,760		₺637
K340	SIR S32T - IR16	32	-	300	60	21,5	39	1,830		₺975
K341	SIR S40T - IR16	40	-	300	60	24,5	45	2,830		₺1.430
K342	SIR S50U - IR16	50	-	350	75	28,7	54	5,337		₺1.625
K342-1	SIR S20P - IR22	20	-	170	40	15,6	24	0,433		₺566
K343	SIR S25R - IR22	25	-	200	45	16,1	30	0,760		₺637
K344	SIR S32T - IR22	32	-	300	40	22	39	1,820	22 IR	₺975
K345	SIR S40T - IR22	40	-	300	60	25,6	46	2,840		₺1.430
K346	SIR S50U - IR22	50	-	350	75	30,6	56	5,335		₺1.625
K347	SIR S32S - IR27	32	-	250	60	22,6	40	1,523		₺1.495
K347-1	SIR S40T - IR27	40	-	300	60	26,6	48	2,890	27 IR	₺1.755
K347-2	SIR S50U - IR27	50	-	350	75	31,6	58	5,177		₺1.885
K347-4	SIR S60V - IR27	60	-	400	75	36,6	68	8,700		₺2.860

Kod					
K337-1	TC058 M2x4,2	--	--	--	T6
K337-2	TC058-1 M2x4,6	--	--	--	T8
K337-3-K337-5	TC060 M2,5x5,5	--	--	--	T8
K337-6-K337-7	TC067 M3,5x8,5	--	--	--	T15
K338-K342	TC068 M3,5x11	TA060	BSP010	TC062 M3	T15
K342-1	TC078 M4x11	--	--	--	T15
K343-K346	TC077 M4x15	TA063	BSP010	TC062 M3	T15
K347 - K347-4	TC086 M5x18	TA065	--	TC053M4	T20



İç Çap Diş Katerleri/R Soğutmalı

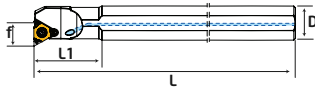
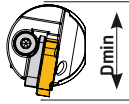
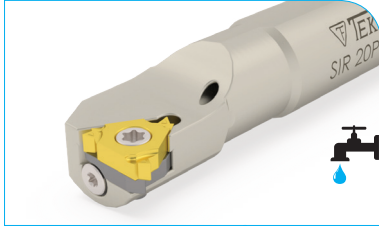

Sipariş Kodu	Ürün Kodu	Ölçüler (mm)					Delik Çapı	Uç	Fiyat
		D	L	L1	f	Dmin			
K327-1	SIR A16K - IR11	16	125	25	7,4	12	0,165	11 IR	₺615
K327-2	SIR A16M - IR16	16	150	32	10,2	16	0,220		₺615
K327-3	SIR A20P - IR16	20	170	40	11,7	19	0,380		₺663
K327-4	SIR A20P - IR16	20	170	40	13,7	24	0,412	16 IR	₺663
K327-5	SIR A25R - IR16	25	200	45	16,2	29	0,710		₺728
K327-6	SIR A25R - IR22	25	200	45	18,1	29	0,730	22 IR	₺767

Kod					
K327-1	TC060 M2,5x5,5	--	--	--	T8
K327-2-K327-3	TC067 M3,5x8,5	--	--	--	T8
K327-4-K327-5	TC068 M3,5x11	TA060	BSP10	TC062 M3	T15
K327-6	TC077 M4x15	TA063			

İç Çap Diş Katerleri/L

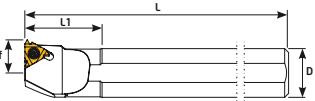
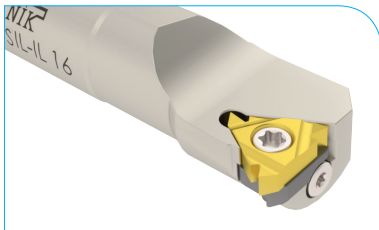



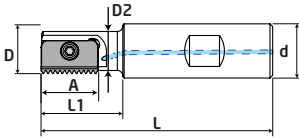

Sipariş Kodu	Ürün Kodu	Ölçüler (mm)					Delik Çapı	Uç	Fiyat
		D	L	L1	f	Dmin			
K330	SIL S20Q - ER16	20	180	40	13,4	24	0,440		₺563
K331	SIL S25R - ER16	25	200	45	16,1	29	0,760		₺637
K332	SIL S32T - ER16	32	300	60	21,5	39	1,830	16ER	₺975
K333	SIL S40T - ER16	40	300	60	24,5	45	2,830		₺1.430
K334	SIL S25R - ER22	25	200	45	16,1	30	0,760		₺637
K335	SIL S32T - ER22	32	300	40	22	39	1,820	22ER	₺975
K336	SIL S40T - ER22	40	300	60	24,5	50	2,840		₺1.430

Kod					
K330-K333	TC068 M3,5x11	TA061	BSP010	TC062 M3	T15
K334-K336	TC077 M4x15	TA062			

Diş Açma Takımları Soğutmalı





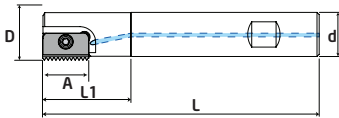

Sipariş Kodu	Ürün Kodu	Ölçüler (mm)							Uç	Fiyat
		A	D	d	D2	L	L1			
DC201	D9,5 d20 L085 A12 S12	12	9,5	20	7,5	85	14	0,195	S12	₺995
DC202	D9,9 d20 L085 A12 S12	12	9,9	20	7,6	85	16	0,191	S12	₺995
DC203	D12 d20 L075 A14 S14	14	12	20	8,9	75	20	0,156	S14	₺995
DC204	D14,5 d20 L085 A14 S14	14	14,5	20	11,2	85	25	0,179	S14	₺995
DC205	D17 d20 L085 A14 S14	14	17	20	13,4	85	30	0,180	S14	₺995
DC206	D18 d20 L085 A21 S21	21	18	20	14,4	85	30	0,176	S21	₺1.073
DC207	D21 d20 L094 A21 S21	21	21	20	16,5	94	40	0,204	S21	₺1.112
DC208	D29 d25 L110 A30 S30	30	29	25	22,4	110	50	0,390	S30	₺1.209
DC209	D48 d40 L153 A40 S40	40	48	40	35	153	78	1,325	S40	₺1.385

Kod			
DC200-DC202	TC092 M2,5x5,5	T8	
DC203-DC205	TC096 M2,5x7	T15	
DC206-DC207	TC074 M4x10	T20	
DC208	TC256 M5x12		
DC209	TC086 M5x18		

Diş Açma Takımları Soğutmalı





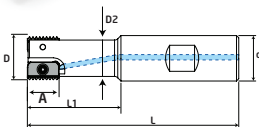

Sipariş Kodu	Ürün Kodu	Ölçüler (mm)					Uç	Fiyat	
		A	D	d	L	L1			
DC210	D25 d20 L125 A21 S21	21	25	20	125	40	0,320	S21	₺1.131
DC211	D31 d25 L150 A30 S30	30	31	25	150	60	0,597	S30	₺1.268
DC212	D38 d32 L150 A30 S30	30	38	32	150	60	1,005	S30	₺1.268
DC213	D48 d40 L210 A40 S40	40	48	40	210	78	2,068	S40	₺1.326

Kod			
DC210	TC074 M4x10	T15	
DC211-DC212	TC256 M5x12	T20	
DC213	TC086 M5x18		

Diş Açma Takımları Soğutmalı



Sipariş Kodu	Ürün Kodu	Ölçüler (mm)							Uç	Fiyat
		A	D	d	D2	L	L1			
DC214	D20 d20 L093 A14 S14	14	20	20	16	93	41	0,202	S14	₺1.492
DC215	D30 d25 L108 A21 S21	21	30	25	24	108	52	0,401	S21	₺1.531
DC216	D40 d32 L130 A30 S30	30	40	32	30	130	70	0,781	S30	₺1.531
DC217	D50 d40 L153 A40 S40	40	50	40	38	153	78	1,455	S40	₺1.599

Kod			
DC214	TC093 M2,5x7	T8	
DC215	TC074 M4x10	T15	
DC216	TC256 M5x12	T20	
DC217	TC086 M5x18		

Dış Çap Kater Soğutmalı

TEKNİK
Cutting Tools

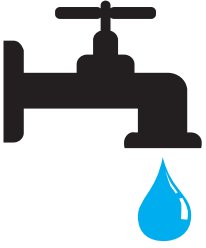
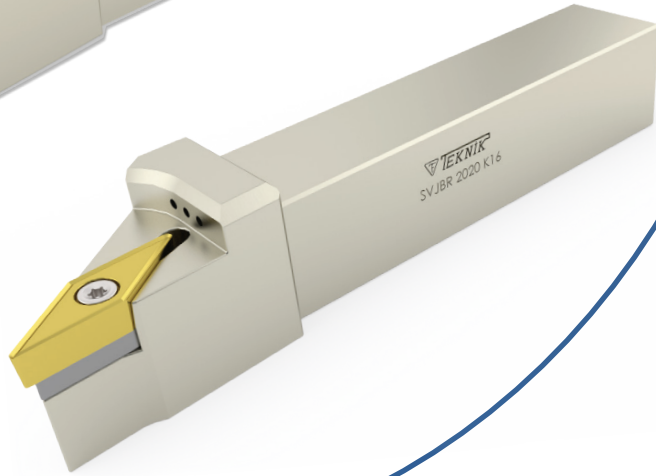
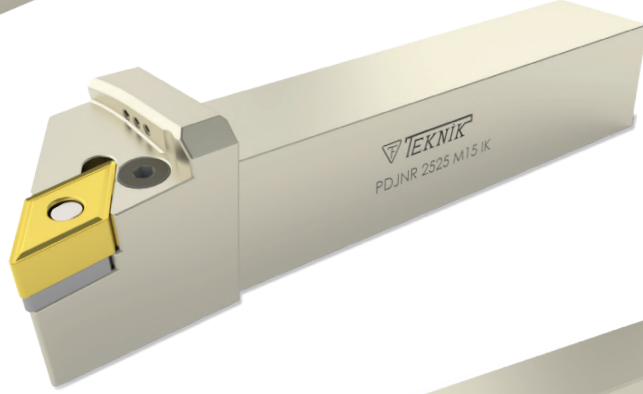

www.teknikcuttingtools.com



Kalite için TEKNİK çözüm





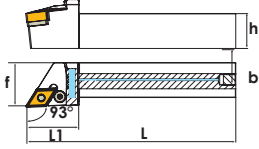
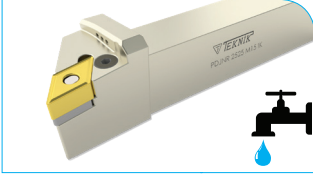

Technical solution for quality

70-73









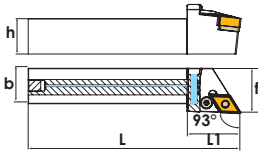
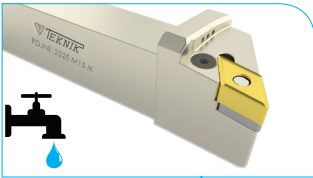

93° PDJNR IC



Sipariş Kodu	Ürün Kodu	Ölçüler (mm)						Uç	Fiyat
		L	L1	h	f	b			
AP110	PDJNR 2020 K15-IKG1/8	125	30	20	25	20	0,409	DNMG 1506	₺1.158
AP112	PDJNR 2525 M15-IKG1/8	150	38	25	32	25	0,759	ISO.	₺1.223
Kod									
AP110	TH822	TA014-1	TS-4	TL4B	3 Allen				
AP112	TH825								







93° PDJNL IC

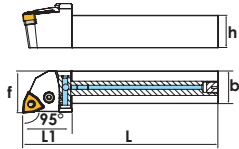

Sipariş Kodu	Ürün Kodu	Ölçüler (mm)						Uç	Fiyat
		L	L1	h	f	b			
AP122	PDJNL 2020 K15-IKG1/8	125	40	20	25	20	0,409	DNMG 1506	₺1.158
AP124	PDJNL 2525 M15-IKG1/8	150	40	25	32	25	0,759	ISO.	₺1.223
Kod									
AP122	TH822	TA014-1	TS-4	TL4B	3 Allen				
AP124	TH825								







95° PCLNR IC

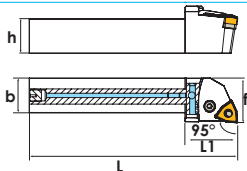

Sipariş Kodu	Ürün Kodu	Ölçüler (mm)						Uç	Fiyat
		L	L1	h	f	b			
AP129	PCLNR 1616 H12-IKG1/8	100	28	16	20	16	0,236	CNMG 1204	₺1.158
AP130	PCLNR 2020 K12-IKG1/8	125	28	20	25	20	0,428	ISO.	₺1.158
AP132	PCLNR 2525 M12-IKG1/8	150	30	25	32	25	0,781		₺1.223
Kod									
AP129	TH818	TA016-1	TS4	TL4	3 Allen				
AP130-AP132	TH821								

95° PCLNL IC



Sipariş Kodu	Ürün Kodu	Ölçüler (mm)						Uç	Fiyat
		L	L1	h	f	b			
AP139	PCLNL 1616 H12-IKG1/8	100	28	16	20	16	0,236		₺1.158
AP140	PCLNL 2020 K12-IKG1/8	125	28	20	25	20	0,428	CNMG 1204	₺1.158
AP142	PCLNL 2525 M12-IKG1/8	150	30	25	32	25	0,781	ISO.	₺1.223
Kod									
AP139	TH818	TA016-1	TS4	TL4	3 Allen				
AP140-AP142	TH821								

95° PWLNR 08 IC

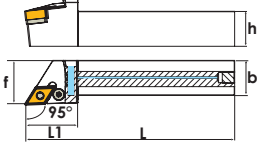
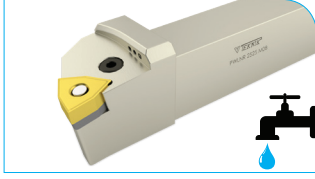

Sipariş Kodu	Ürün Kodu	Ölçüler (mm)						Uç	Fiyat
		L	L1	h	f	b	kg		
AP150	PWLNR 2020 K08-IKG1/8	125	30	20	25	20	0,425	WNMG 0804	₺1.158
AP151	PWLNR 2525 M08-IKG1/8	150	38	25	32	25	0,782	ISO.	₺1.223
						3 Allen			
		TH821	TA020-1	TS4	TL4	3 Allen			

95° PWLNL 08 IC

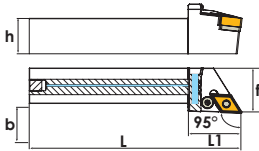

Sipariş Kodu	Ürün Kodu	Ölçüler (mm)						Uç	Fiyat
		L	L1	h	f	b	kg		
AP155	PWLNL 2020 K08-IKG1/8	125	30	20	25	20	0,425	WNMG 0804	₺1.158
AP156	PWLNL 2525 M08-IKG1/8	150	38	25	32	25	0,782	ISO.	₺1.223
						3 Allen			
		TH821	TA020-1	TS4	TL4	3 Allen			

95° PWLNR 06 IC

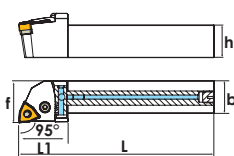

Sipariş Kodu	Ürün Kodu	Ölçüler (mm)						Uç	Fiyat
		L	L1	h	f	b	kg		
AP158	PWLNR 1616 H06-IKG1/8	100	30	16	20	16	0,218		₺1.158
AP160	PWLNR 2020 K06-IKG1/8	125	30	20	25	20	0,415	WNMG 0604	₺1.158
AP161	PWLNR 2525 M06-IKG1/8	150	30	25	32	25	0,756	ISO.	₺1.223
						2,5 Allen			
		TH617	TA021	TS3	TL3	2,5 Allen			

95° PWLNL 06 IC

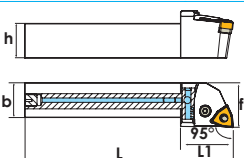
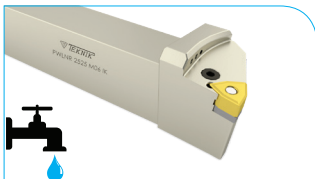



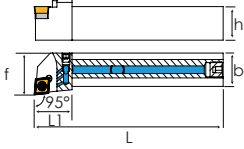
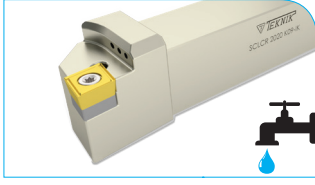

Sipariş Kodu	Ürün Kodu	Ölçüler (mm)						Uç	Fiyat
		L	L1	h	f	b	kg		
AP164	PWLNL 1616 H06-IKG1/8	100	30	16	20	16	0,218		₺1.158
AP165	PWLNL 2020 K06-IKG1/8	125	30	20	25	20	0,415	WNMG 0604	₺1.158
AP166	PWLNL 2525 M06-IKG1/8	150	30	25	32	25	0,756	ISO.	₺1.223
						2,5 Allen			
		TH617	TA021	TS3	TL3	2,5 Allen			

95° SCLCR IC







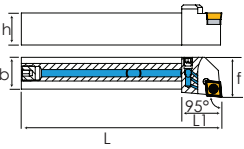
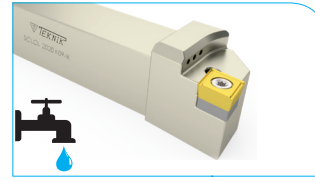

Sipariş Kodu	Ürün Kodu	Ölçüler (mm)						Uç	Fiyat
		L	L1	h	f	b			
AP500	SCLCR 1616 H09-İK	100	25	16	20	16	0,205	CCMT 09T3	₺1.158
AP501	SCLCR 2020 K09-İK	125	25	20	25	20	0,418	ISO.	₺1.158
AP503	SCLCR 2525 M12-İK	150	30	25	32	25	0,771	CCMT 1204	₺1.180

Kod					
AP500-AP501	TC068 M3,5x11	TA015	TC048 M5	T15	
AP503	TC075 M4x11	TA15-1	TC049-1 M6		

95° SCLCL IC







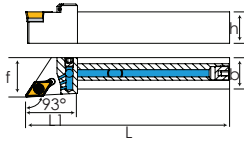
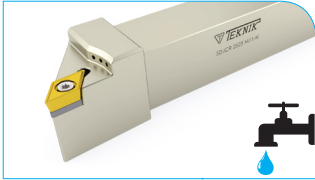

Sipariş Kodu	Ürün Kodu	Ölçüler (mm)						Uç	Fiyat
		L	L1	h	f	b			
AP505	SCLCL 1616 H09-İK	100	25	16	20	16	0,205	CCMT 09T3	₺1.158
AP506	SCLCL 2020 K09-İK	125	25	20	25	20	0,418	ISO.	₺1.158
AP508	SCLCL 2525 M12-İK	150	30	25	32	25	0,771	CCMT 1204	₺1.180

Kod					
AP505-AP506	TC068 M3,5x11	TA015	TC048 M5	T15	
AP508	TC075 M4x11	TA15-1	TC049-1 M6		

93° SDJCR IC







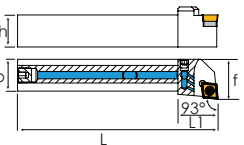
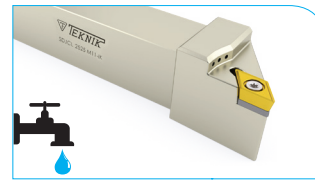

Sipariş Kodu	Ürün Kodu	Ölçüler (mm)						Uç	Fiyat
		L	L1	h	f	b			
AP510	SDJCR 1616 H11-İK	100	32	16	20	16	0,204	DCMT 11T3	₺1.158
AP511	SDJCR 2020 K11-İK	125	32	20	25	20	0,404	ISO.	₺1.158
AP512	SDJCR 2525 M11-İK	150	35	25	32	25	0,735		₺1.180

					
	TC068 M3,5x11	TA030	TC048 M5	T8	

93° SDJCL IC







Sipariş Kodu	Ürün Kodu	Ölçüler (mm)						Uç	Fiyat
		L	L1	h	f	b			
AP515	SDJCL 1616 H11-İK	100	32	16	16	16	0,204	DCMT 11T3	₺1.158
AP516	SDJCL 2020 K11-İK	125	32	20	25	20	0,404	ISO.	₺1.158
AP517	SDJCL 2525 M11-İK	150	35	25	32	25	0,735		₺1.180

					
	TC068 M3,5x11	TA030	TC048 M5	T8	

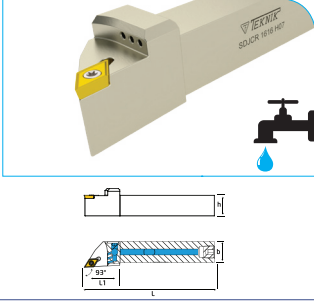
**NEW
PRODUCT**

93° SDJCR IC





Sipariş Kodu	Ürün Kodu	Ölçüler (mm)						Uç	Fiyat
		L	L1	h	f	b	kg		
AP560	SDJCR 1212 K07-IC	125	27	12	16	12	0,175		₺1.139
AP561	SDJCR 1616 H07-IC	100	27	16	20	16	0,210	DCMT 0702	₺1.158
AP562	SDJCR 2020 K07-IC	125	27	20	25	20	0,400	ISO.	₺1.158
Kod									
AP560-AP562		TC060 M2,5x5,5		T8					

**NEW
PRODUCT**

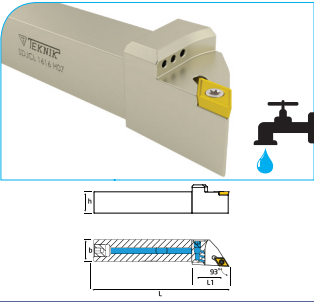
93° SDJCL IC





Sipariş Kodu	Ürün Kodu	Ölçüler (mm)						Uç	Fiyat
		L	L1	h	f	b	kg		
AP565	SDJCL 1212 K07-IC	125	16	16	12	16	0,175		₺1.139
AP566	SDJCL 1616 H07-IC	100	27	16	20	16	0,210	DCMT 0702	₺1.158
AP567	SDJCL 2020 K07-IC	125	27	20	25	20	0,400	ISO.	₺1.158
Kod									
AP565-AP567		TC060 M2,5x5,5		T8					

**NEW
PRODUCT**

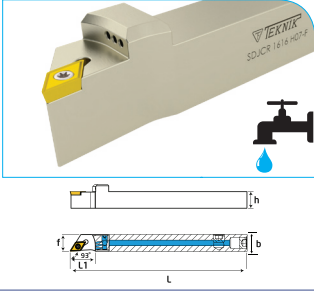
93° SDJCR -F IC





Sipariş Kodu	Ürün Kodu	Ölçüler (mm)						Uç	Fiyat
		L	L1	h	f	b	kg		
AP569	SDJCR 1212 K07-F-IC	125	27	12	16	12	0,175	ISO.	₺1.139
AP570	SDJCR 1616 H07-F-IC	100	27	16	16	16	0,210	DCMT 0702	₺1.158
Kod									
AP569-AP570		TC060 M2,5x5,5		T8					

**NEW
PRODUCT**

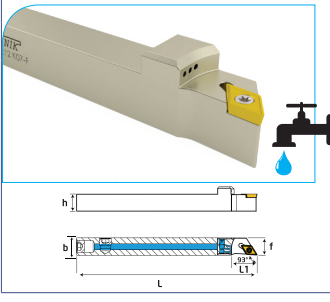
93° SDJCL-F IC





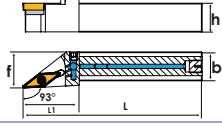
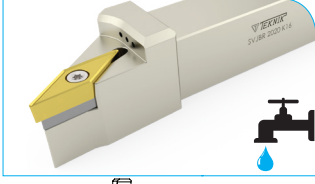

Sipariş Kodu	Ürün Kodu	Ölçüler (mm)						Uç	Fiyat
		L	L1	h	f	b	kg		
AP573	SDJCL 1212 K07 F-IC	125	27	12	12	12	0,175	ISO.	₺1.139
AP574	SDJCL 1616 H07-F-IC	100	27	16	16	16	0,210	DCMT 0702	₺1.158
Kod									
AP573-AP574		TC060 M2,5x5,5		T8					

93° SVJBR IC



Sipariş Kodu	Ürün Kodu	Ölçüler (mm)						Uç	Fiyat
		L	L1	h	f	b			
AP540	SVJBR 1010 J11-İK	110	30	10	12	10	0,097	VBMT 1103	₺1.139
AP541	SVJBR 1212 J11-İK	110	32	12	16	12	0,141	ISO.	₺1.139
AP545	SVJBR 2020 K16-İK	125	40	20	25	20	0,192	VBMT 1604	₺1.158
AP546	SVJBR 2525 M16-İK	150	40	25	32	25	0,192	ISO.	₺1.180

Kod    

AP540-AP541 TC061 M2,5x6,5
AP545-AP546 TC068 M3,5x11





TA034 TC048 T8 T15

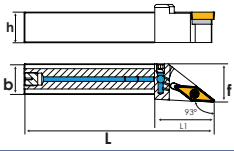

93° SVJBL IC



Sipariş Kodu	Ürün Kodu	Ölçüler (mm)						Uç	Fiyat
		L	L1	h	f	b			
AP550	SVJBL 1010 J11-İK	110	30	10	12	10	0,097	VBMT 1103	₺1.139
AP551	SVJBL 1212 J11-İK	110	32	12	16	12	0,141	ISO.	₺1.139
AP555	SVJBL 2020 K16-İK	125	40	20	25	20	0,192	VBMT 1604	₺1.158
AP556	SVJBL 2525 M16-İK	150	40	25	32	25	0,192	ISO.	₺1.180

Kod    

AP550-AP551 TC061 M2,5x6,5
AP555-AP556 TC068 M3,5x11





TA034 TC048 T8 T15

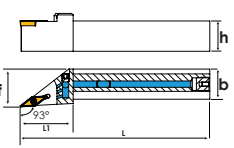
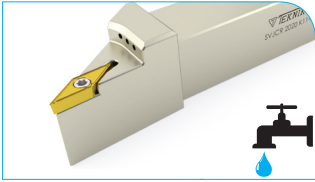

93° SVJCR IC



Sipariş Kodu	Ürün Kodu	Ölçüler (mm)						Uç	Fiyat
		L	L1	h	f	b			
AP520	SVJCR 1616 H11-İK	100	25	16	20	16	0,204	VCMT 1103	₺1.158
AP521	SVJCR 2020 K11-İK	125	33	20	25	20	0,378	ISO.	₺1.158
AP525	SVJCR 2020 K16-İK	125	33	20	25	20	0,385	VCMT 1604	₺1.158
AP526	SVJCR 2525 M16-İK	150	40	25	32	25	0,683	ISO.	₺1.180

Kod    

AP520-AP521 TC061 M2,5x6,5
AP525-AP526 TC068 M3,5x11





TA034 TC048 T8 T15

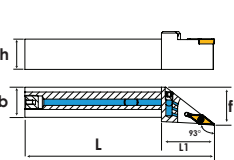

93° SVJCL IC



Sipariş Kodu	Ürün Kodu	Ölçüler (mm)						Uç	Fiyat
		L	L1	h	f	b			
AP530	SVJCL 1616 H11-İK	100	25	16	20	16	0,204	VCMT 1103	₺1.158
AP531	SVJCL 2020 K11-İK	125	33	20	25	20	0,378	ISO.	₺1.158
AP535	SVJCL 2020 K16-İK	125	33	20	25	20	0,385	VCMT 1604	₺1.158
AP536	SVJCL 2525 M16-İK	150	40	25	32	25	0,683	ISO.	₺1.180

Kod    

AP530-AP531 TC061 M2,5x6,5
AP535-AP536 TC068 M3,5x11





TA034 TC048 T8 T15

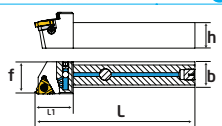

Diş Çap Diş Katerleri IC



Sipariş Kodu	Ürün Kodu	Ölçüler (mm)					Uç	Fiyat	
		h	b	f	L	L1			
AP602	SER 2020 K16 - ER16 İK	20	20	20	125	30	0,449	16 ER	₺1.112
AP604	SER 2525 M16 - ER16 İK	25	25	25	150	30	0,842		₺1.170

Kod     

TC068 M3,5x11 TA061 TA060 TC062 M3 T15



P Sistem Dış Çap Kater



www.teknikcuttingtools.com



Kalite için TEKNİK çözüm

Technical solution for quality

76-77



93° PDJNR

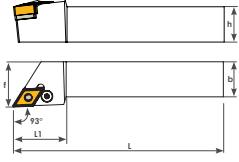
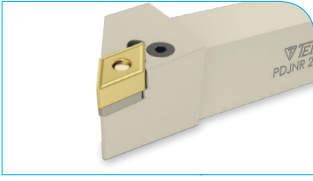

Sipariş Kodu	Ürün Kodu	Ölçüler (mm)						Uç	Fiyat
		L	L1	h	f	b	kg		
P107	PDJNR 1616 H11	100	25	16	25	16	0,242	DNMG 1104	₺703
P108	PDJNR 2020 K11	125	30	20	25	20	0,435	ISO.	₺703
P109	PDJNR 2525 M11	150	30	25	32	25	0,767		₺725
P110	PDJNR 2020 K15	125	35	20	25	20	0,402		₺703
P112	PDJNR 2525 M15	150	38	25	32	25	0,730	DNMG 1506	₺725
P114	PDJNR 3232 P15	170	38	32	40	32	1,384	ISO.	₺829

Kod	TH613	TA013	TS-3	TL3	2,5 Allen
P107	TH613	TA013	TS-3	TL3	2,5 Allen
P108-P109	TH617	TA013	TS-3	TL3	2,5 Allen
P110	TH822	TA014-1	TS-4	TL4B	3 Allen
P112-P114	TH825	TA014-1	TS-4	TL4B	3 Allen

93° PDJNL

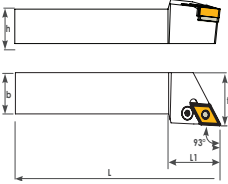
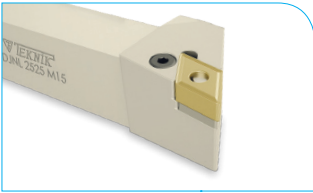

Sipariş Kodu	Ürün Kodu	Ölçüler (mm)						Uç	Fiyat
		L	L1	h	f	b	kg		
P119	PDJNL 1616 H11	100	25	16	25	16	0,242	DNMG 1104	₺703
P120	PDJNL 2020 K11	125	30	20	25	20	0,435	ISO.	₺703
P121	PDJNL 2525 M11	150	30	25	32	25	0,767		₺725
P122	PDJNL 2020 K15	125	35	20	25	20	0,402		₺703
P124	PDJNL 2525 M15	150	38	25	32	25	0,730	DNMG 1506	₺725
P126	PDJNL 3232 P15	170	38	32	40	32	1,384	ISO.	₺829

Kod	TH613	TA013	TS-3	TL3	2,5 Allen
P119	TH613	TA013	TS-3	TL3	2,5 Allen
P120-P121	TH617	TA013	TS-3	TL3	2,5 Allen
P122	TH822	TA014-1	TS-4	TL4B	3 Allen
P124-P126	TH825	TA014-1	TS-4	TL4B	3 Allen

95° PCLNR

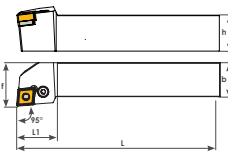
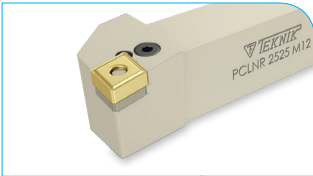

Sipariş Kodu	Ürün Kodu	Ölçüler (mm)						Uç	Fiyat
		L	L1	h	f	b	kg		
P126-1	PCLNR 1616 H09	100	20	16	20	16	0,231	CNMG 09T3	₺703
P127	PCLNR 2020 K09	125	22	20	25	20	0,428	ISO.	₺703
P128	PCLNR 2525 M09	150	22	25	32	25	0,785		₺725
P129	PCLNR 1616 H12	100	30	16	20	16	0,225		₺703
P130	PCLNR 2020 K12	125	30	20	25	20	0,421	CNMG 1204	₺703
P132	PCLNR 2525 M12	150	30	25	32	25	0,766	ISO.	₺725
P134	PCLNR 3232 P12	170	30	32	40	32	1,429		₺829

Kod	TH617	TA023	TS3	TL3	2,5 Allen
(P126-1)-(P128)	TH617	TA023	TS3	TL3	2,5 Allen
P129	TH818	TA016-1	TS4	TL4	3 Allen
P130-134	TH821	TA016-1	TS4	TL4	3 Allen

95° PCLNL

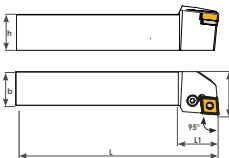
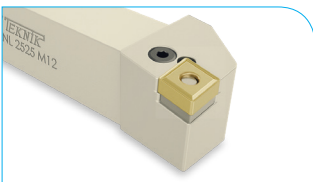

Sipariş Kodu	Ürün Kodu	Ölçüler (mm)						Uç	Fiyat
		L	L1	h	f	b	kg		
P136	PCLNL 1616 H09	100	20	16	20	16	0,231	CNMG 09T3	₺703
P137	PCLNL 2020 K09	125	22	20	25	20	0,428	ISO.	₺703
P138	PCLNL 2525 M09	150	22	25	32	25	0,785		₺725
P139	PCLNL 1616 H12	100	30	16	20	16	0,225		₺703
P140	PCLNL 2020 K12	125	30	20	25	20	0,421	CNMG 1204	₺703
P142	PCLNL 2525 M12	150	30	25	32	25	0,766	ISO.	₺725
P144	PCLNL 3232 P12	170	30	32	40	32	1,429		₺829

Kod	TH617	TA023	TS3	TL3	2,5 Allen
P136-P138	TH617	TA023	TS3	TL3	2,5 Allen
P139	TH818	TA016-1	TS4	TL4	3 Allen
P140-144	TH821	TA016-1	TS4	TL4	3 Allen

95° PWLNR 08

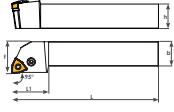

Sipariş Kodu	Ürün Kodu	Ölçüler (mm)						Uç	Fiyat
		L	L1	h	f	b	kg		
P150	PWLNR 2020 K08	125	30	20	25	20	0,430		₺703
P151	PWLNR 2525 M08	150	38	25	32	25	0,773	WNMG 0804	₺725
P152	PWLNR 3232 P08	170	38	32	40	32	1,421	ISO.	₺829

TH821	TA020-1	TS4	TL4	3 Allen	

95° PWLNL 08

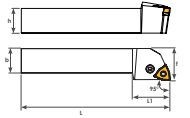

Sipariş Kodu	Ürün Kodu	Ölçüler (mm)						Uç	Fiyat
		L	L1	h	f	b	kg		
P155	PWLNL 2020 K08	125	30	20	25	20	0,430		₺703
P156	PWLNL 2525 M08	150	38	25	32	25	0,773	WNMG 0804	₺725
P157	PWLNL 3232 P08	170	38	32	40	32	1,421	ISO.	₺829

TH821	TA020-1	TS4	TL4	3 Allen	

95° PWLNR 06

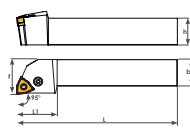
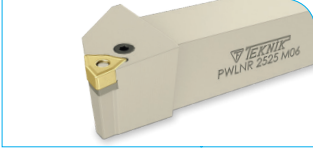

Sipariş Kodu	Ürün Kodu	Ölçüler (mm)						Uç	Fiyat
		L	L1	h	f	b	kg		
P158	PWLNR 1616 H06	100	30	16	20	16	0,223		₺703
P160	PWLNR 2020 K06	125	30	20	25	20	0,429	WNMG 0604	₺703
P161	PWLNR 2525 M06	150	30	25	32	25	0,758	ISO.	₺725

TH617	TA021	TS3	TL3	2,5 Allen	

95° PWLNL 06

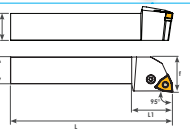
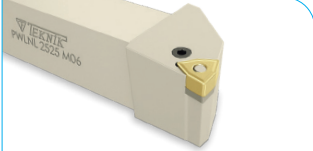

Sipariş Kodu	Ürün Kodu	Ölçüler (mm)						Uç	Fiyat
		L	L1	h	f	b	kg		
P164	PWLNL 1616 H06	100	30	16	20	16	0,223		₺703
P165	PWLNL 2020 K06	125	30	20	25	20	0,429	WNMG 0604	₺703
P166	PWLNL 2525 M06	150	30	25	32	25	0,758	ISO.	₺725

TH617	TA021	TS3	TL3	2,5 Allen	

45° PSSNR

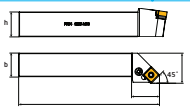
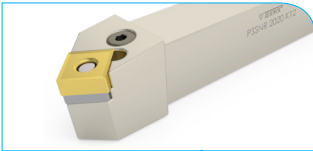

Sipariş Kodu	Ürün Kodu	Ölçüler (mm)						Uç	Fiyat
		L	L1	h	f	b	kg		
P170	PSSNR 1616 H12	100	30	16	20	16	0,218		₺703
P171	PSSNR 2020 K12	125	30	20	25	20	0,416	SNMG 1204	₺703
P172	PSSNR 2525 M12	150	30	25	32	25	0,742	ISO.	₺725

Kod						
P170	TH818	TA050	TS4	TL4	3 Allen	
P171-P172	TH821					

45° PSSNL

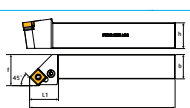
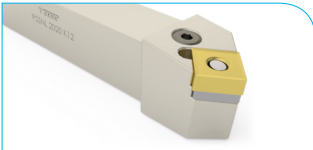

Sipariş Kodu	Ürün Kodu	Ölçüler (mm)						Uç	Fiyat
		L	L1	h	f	b	kg		
P180	PSSNL 1616 H12	100	30	16	20	16	0,218		₺703
P181	PSSNL 2020 K12	125	30	20	25	20	0,416	SNMG 1204	₺703
P182	PSSNL 2525 M12	150	30	25	32	25	0,742	ISO.	₺725

Kod						
P180	TH818	TA050	TS4	TL4	3 Allen	
P181-P182	TH821					

TEKNIK

» ÇALIŞKAN »
« TEKNOLOJİ «

www.teknikcuttingtools.com



TEKNIK APKT 16
M3.5
Ø32-Z8-L150-C32 T15-T0712

D-M-C Sistem Dış Çap Kater

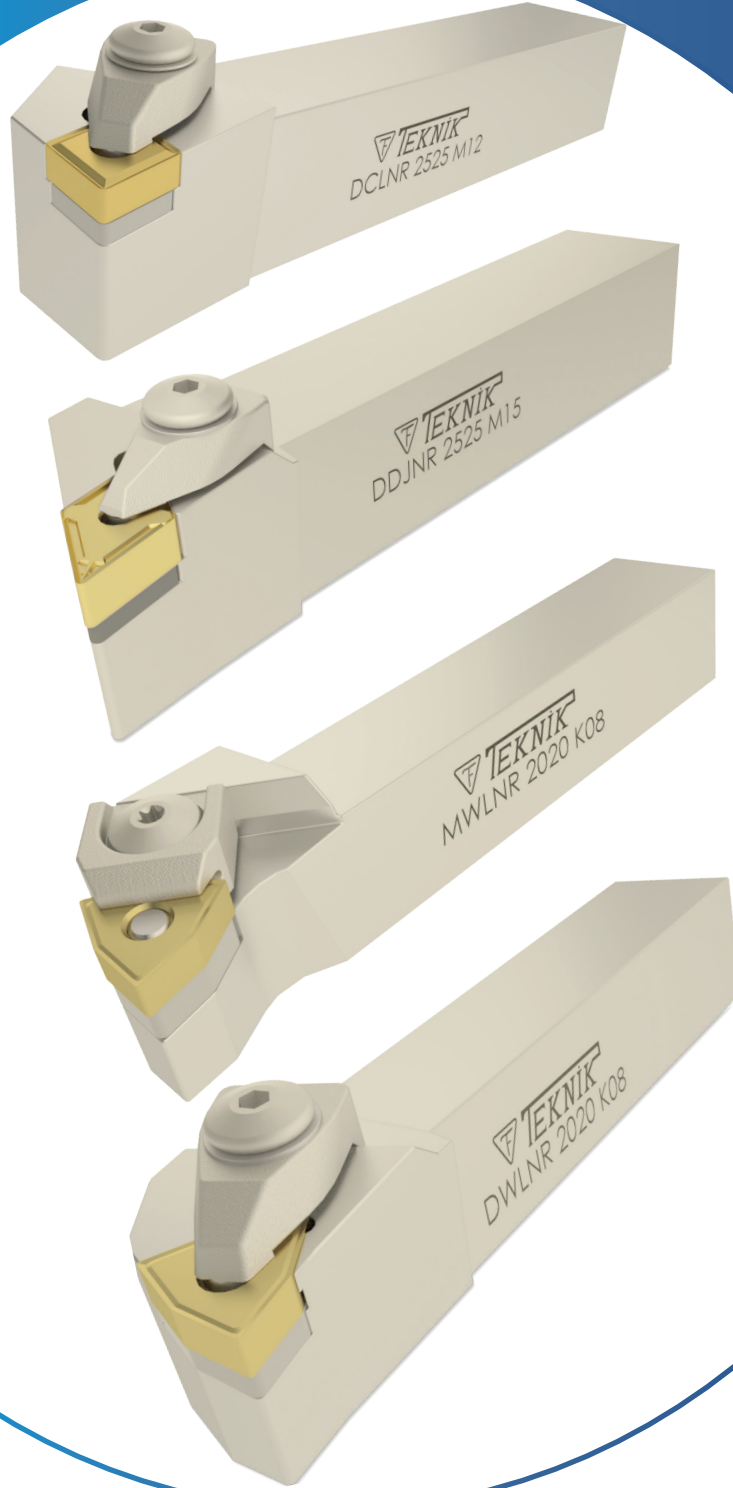

www.teknikcuttingtools.com



Kalite için TEKNİK çözüm

Technical solution for quality

80-85



93° DDJNR

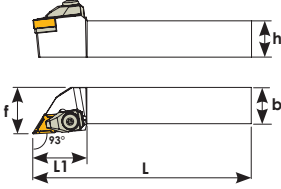
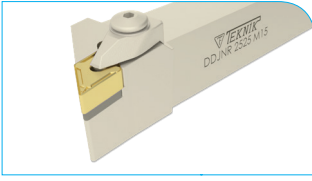

Sipariş Kodu	Ürün Kodu	Ölçüler (mm)						Uç	Fiyat
		L	L1	h	f	b			
D167	DDJNR 2020 K11	125	30	20	25	20	0,421	DNMG 1104	₺703
D168	DDJNR 2525 M11	150	30	25	32	25	0,751	ISO.	₺725
D170	DDJNR 2020 K15	125	35	20	25	20	0,425		₺703
D172	DDJNR 2525 M15	150	35	25	32	25	0,756	DNMG 1506	₺725
D174	DDJNR 3232 P15	170	35	32	40	32	1,345	ISO.	₺829

Kod



D167 - D168	TC046 M5	TA013	TC034 M3x7	BK024	BY041	BSP031	3 Allen	
D170 - D174	TC044 M6	TA014-1	TC038 M4x10	BK020	BY040	BSP030	3 Allen	

93° DDJNL

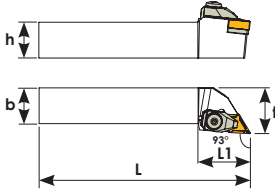
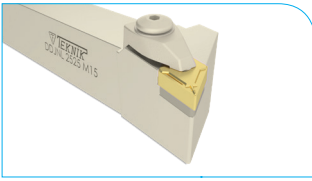

Sipariş Kodu	Ürün Kodu	Ölçüler (mm)						Uç	Fiyat
		L	L1	h	f	b			
D307-1	DDJNL 2020 K11	125	30	20	25	20	0,421	DNMG 1104	₺703
D308	DDJNL 2525 M11	150	30	25	32	25	0,751	ISO.	₺725
D310	DDJNL 2020 K15	125	35	20	25	20	0,425		₺703
D312	DDJNL 2525 M15	150	35	25	32	25	0,756	DNMG 1506	₺725
D314	DDJNL 3232 P15	170	35	32	40	32	1,345	ISO.	₺829

Kod



D307-1 - D308	TC046 M5	TA013	TC034 M3x7	BK024	BY041	BSP031	3 Allen	
D310 - D314	TC044 M6	TA014-1	TC038 M4x10	BK020	BY040	BSP030	3 Allen	

93° DDJNR

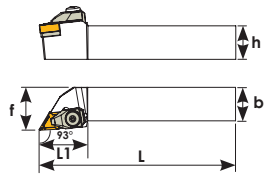
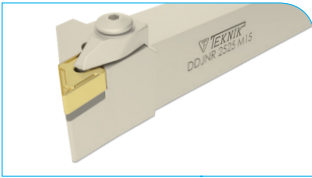



Sipariş Kodu	Ürün Kodu	Ölçüler (mm)						Uç	Fiyat
		L	L1	h	f	b			
D171	DDJNR 2020 K15	125	38	20	25	20	0,426	DNMG 1504	₺703
D169	DDJNR 2525 M15	150	38	25	32	25	0,763	ISO.	₺725

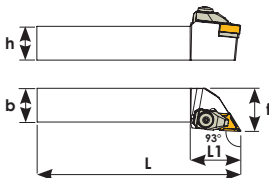
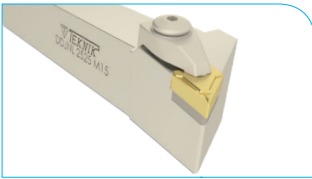

TC044 M6	TA014-1	TC038 M4x10	BK020	BY040	BSP030	3 Allen	
----------	---------	-------------	-------	-------	--------	---------	---

93° DDJNL



Sipariş Kodu	Ürün Kodu	Ölçüler (mm)						Uç	Fiyat
		L	L1	h	f	b			
D313	DDJNL 2020 K15	125	38	20	25	20	0,426	DNMG 1504	₺703
D309	DDJNL 2525 M15	150	38	25	32	25	0,763	ISO.	₺725



TC044 M6	TA014-1	TC038 M4x10	BK020	BY040	BSP030	3 Allen	
----------	---------	-------------	-------	-------	--------	---------	---

107,5° DDHNR

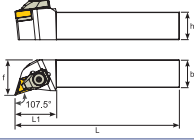

Sipariş Kodu	Ürün Kodu	Ölçüler (mm)						Uç	Fiyat
		L	L1	h	f	b	kg		
D096	DDHNR 2020 K15	125	33	20	25	20	0,428		₺703
D097	DDHNR 2525 M15	150	33	25	32	25	0,753	DNMG 1506	₺725
D098	DDHNR 3232 P15	170	33	32	40	32	1,290	ISO.	₺829

TC044 M6 TA014-1 TC038 M4x10 BK020 BY040 BSP030 3 Allen

107,5° DDHNL

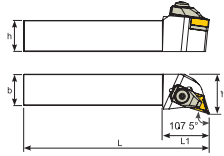

Sipariş Kodu	Ürün Kodu	Ölçüler (mm)						Uç	Fiyat
		L	L1	h	f	b	kg		
D295	DDHNL 2020 K15	125	33	20	25	20	0,428		₺703
D296	DDHNL 2525 M15	150	33	25	32	25	0,753	DNMG 1506	₺725
D297	DDHNL 3232 P15	170	33	32	40	32	1,290	ISO.	₺829

TC044 M6 TA014-1 TC038 M4x10 BK020 BY040 BSP030 3 Allen

62,5° DDNNN

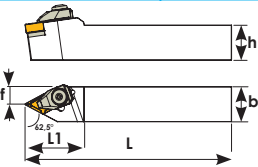
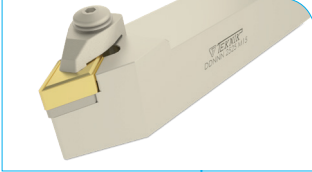

Sipariş Kodu	Ürün Kodu	Ölçüler (mm)						Uç	Fiyat
		L	L1	h	f	b	kg		
D104	DDNNN 2020 K15	125	40	20	10	20	0,404		₺703
D106	DDNNN 2525 M15	150	40	25	12,5	25	0,724	DNMG 1506	₺725
D109	DDNNN 3232 P15	170	40	32	16	32	1,290	ISO.	₺829

TC044 M6 TA014-1 TC038 M4x10 BK020 BY040 BSP030 3 Allen

95° DCLNR

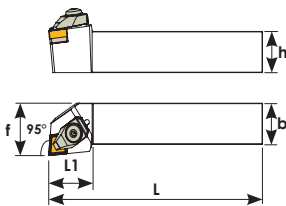
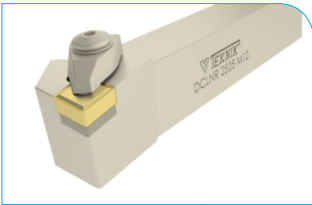

Sipariş Kodu	Ürün Kodu	Ölçüler (mm)						Uç	Fiyat
		L	L1	h	f	b	kg		
D160	DCLNR 2020 K12	125	30	20	25	20	0,441	CNMG 1204	₺703
D162	DCLNR 2525 M12	150	30	25	32	25	0,785	ISO.	₺725
D164	DCLNR 3232 P12	170	30	32	40	32	1,379		₺829
D162-1	DCLNR 2525 M16	150	36	25	32	25	0,432	CNMG 1606	₺829
D165	DCLNR 3232 P16	170	36	32	40	32	1,407	ISO.	₺892
D163	DCLNR 2525 M19	150	40	25	32	25	0,820	CNMG 1906	₺892
D166	DCLNR 3232 P19	170	40	32	40	32	1,430	ISO.	₺1.037
D166-1	DCLNR 4040 S19	250	40	40	40	40	3,195		₺1.490

Kod

D160 - D164 TC044 M6 TA016-1 TC038 M4x10 BK020 BY040 BSP030 3 Allen
 D162-1 - D165 TA022 TC095 M5x11,8 BK018
 D163 - D166-1 TC047 M8 TA017 TC039 M6x12 BK025 BY044 BSP032 5 Allen

95° DCLNL

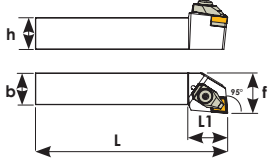
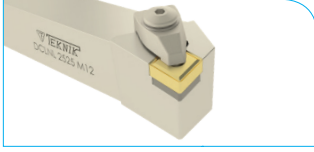

Sipariş Kodu	Ürün Kodu	Ölçüler (mm)						Uç	Fiyat
		L	L1	h	f	b	kg		
D301	DCLNL 2020 K12	125	30	20	25	20	0,441	CNMG 1204	₺703
D302	DCLNL 2525 M12	150	30	25	32	25	0,785	ISO.	₺725
D305	DCLNL 3232 P12	170	30	32	40	32	1,379		₺829
D303	DCLNL 2525 M16	150	36	25	32	25	0,432	CNMG 1606	₺829
D306	DCLNL 3232 P16	170	36	32	40	32	1,407	ISO.	₺892
D304	DCLNL 2525 M19	150	40	25	32	25	0,820	CNMG 1906	₺892
D307	DCLNL 3232 P19	170	40	32	40	32	1,430	ISO.	₺1.037
D307-2	DCLNL 4040 S19	250	40	40	40	40	3,195		₺1.490

Kod								
D301 - D305	TC044 M6	TA016-1	TC038 M4x10	BK020	BY040	BSP030	3 Allen	
D303 - D306	TC044 M6	TA022	TC095 M5x11,8	BK018	BY040	BSP030	3 Allen	
D304 - D307-2	TC047 M8	TA017	TC039 M6x12	BK025	BY044	BSP032	5 Allen	

50° DCMNN

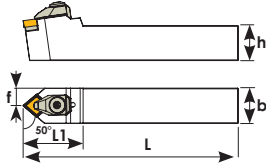

Sipariş Kodu	Ürün Kodu	Ölçüler (mm)						Uç	Fiyat
		L	L1	h	f	b	kg		
D214-1	DCMNN 2020 K12	125	35	20	10	20	0,445	CNMG 1204 ISO.	₺703
D215	DCMNN 2525 M12	150	35	25	12,5	25	0,778		₺725

Kod								
D214-1	TC044 M6	TA016-1	TC038 M4x10	BK020	BY040	BSP030	3 Allen	

40° DCXNN

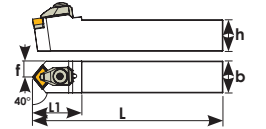
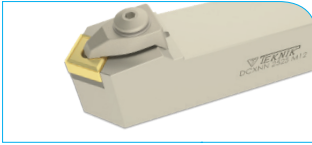

Sipariş Kodu	Ürün Kodu	Ölçüler (mm)						Uç	Fiyat
		L	L1	h	f	b	kg		
D216	DCXNN 2525 M12	150	35	25	12,5	25	0,756	CNMG 1204 ISO.	₺725

Kod								
D216	TC044 M6	TA016-1	TC038 M4x10	BK020	BY040	BSP030	3 Allen	

75° DCKNR

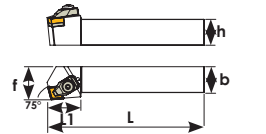
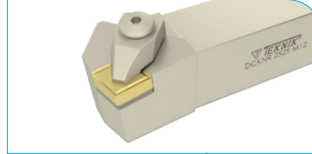

Sipariş Kodu	Ürün Kodu	Ölçüler (mm)						Uç	Fiyat
		L	L1	h	f	b	kg		
D116-1	DCKNR 2525 M12	150	30	25	32	25	0,440	CNMG 1204 ISO	₺725
D162-3	DCKNR 2525 M16	150	40	25	32	25	0,576	CNMG 1606 ISO.	₺829

Kod								
D116-1	TC044 M6	TA016-1	TC038 M4x10	BK020	BY040	BSP030	3 Allen	
D162-3	TC044 M6	TA022	TC095 M5x11,8	BK018	BY040	BSP030	3 Allen	

45° DCSNR

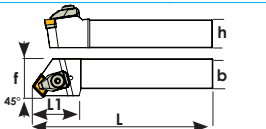
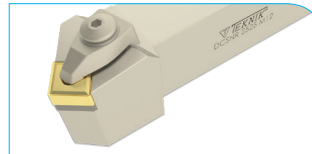

Sipariş Kodu	Ürün Kodu	Ölçüler (mm)						Uç	Fiyat
		L	L1	h	f	b	kg		
D218	DCSNR 2525 M12	150	35	25	32	25	0,774	CNMG 1204 ISO.	₺725

Kod								
D218	TC044 M6	TA016-1	TC038 M4x10	BK020	BY040	BSP030	3 Allen	

45° DSSNR

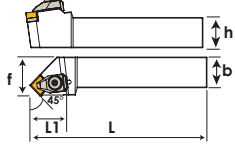
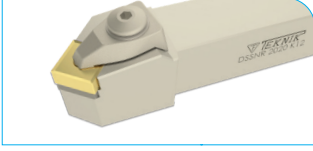

Sipariş Kodu	Ürün Kodu	Ölçüler (mm)						Uç	Fiyat
		L	L1	h	f	b	kg		
D210	DSSNR 2020 K12	125	35	20	25	20	0,440	SNMG 1204	₺703
D212	DSSNR 2525 M12	150	35	25	32	25	0,576	ISO.	₺725
D205	DSSNR 3232 P12	170	36	32	32	40	1,280		₺829
D206	DSSNR 3232 P19	170	46	32	32	40	1,383	SNMG 1906	₺1.158
D207	DSSNR 4040 S19	250	46	40	40	50	3,123	ISO.	₺1.554
D208	DSSNR 4040 S25	250	60	40	40	50	3,012	SNMG 2508	₺1.698

Kod	TC044 M6	TA050	TC038 M4x10	BK020	BY040	BSP030	3 Allen
D210-D205	TC044 M6	TA050	TC038 M4x10	BK020	BY040	BSP030	3 Allen
D206-D207	TC047 M8	TA051	TC039 M6x12	BK025	BY044	BSP032	3 Allen
D208	TC047 M8	TA053	TC041 M8x20	BK027	BY044	BSP032	5 Allen

95° DWLNR

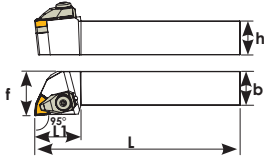
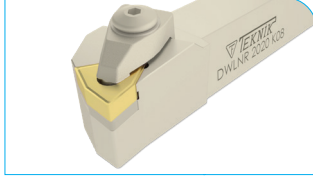

Sipariş Kodu	Ürün Kodu	Ölçüler (mm)						Uç	Fiyat
		L	L1	h	f	b	kg		
D181	DWLNR 1616 H06	100	26	16	20	16	0,229		₺703
D177	DWLNR 2020 K06	125	26	20	25	20	0,436	WNMG 0604	₺703
D179	DWLNR 2525 M06	150	26	25	32	25	0,772	ISO.	₺725
D176	DWLNR 2020 K08	125	32	20	25	20	0,442		₺703
D178	DWLNR 2525 M08	150	32	25	32	25	0,793	WNMG 0804	₺725
D180	DWLNR 3232 P08	170	32	32	40	32	1,377	ISO.	₺829

Kod	TC046 M5	TA021	TC034 M3x7	BK024	BY041	BSP031	3 Allen
D181 - D179	TC046 M5	TA021	TC034 M3x7	BK024	BY041	BSP031	3 Allen
D176 - D180	TC044 M6	TA020-1	TC038 M5x12	BK020	BY040	BSP030	3 Allen

95° DWLNL

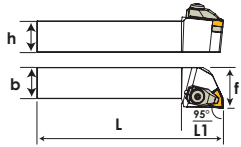
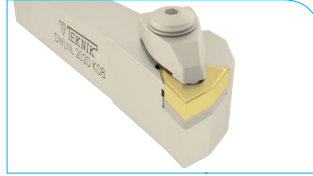

Sipariş Kodu	Ürün Kodu	Ölçüler (mm)						Uç	Fiyat
		L	L1	h	f	b	kg		
D328	DWLNL 1616 H06	100	26	16	20	16	0,229	WNMG 0604	₺703
D329	DWLNL 2020 K06	125	26	20	25	20	0,436	ISO.	₺703
D319	DWLNL 2525 M06	150	26	25	32	25	0,772		₺725
D316	DWLNL 2020 K08	125	32	20	25	20	0,442	WNMG 0804	₺703
D318	DWLNL 2525 M08	150	32	25	32	25	0,793	ISO.	₺725
D320	DWLNL 3232 P08	170	32	32	40	32	1,377		₺829

Kod	TC046 M5	TA021	TC034 M3x7	BK024	BY041	BSP031	3 Allen
D328 - D319	TC046 M5	TA021	TC034 M3x7	BK024	BY041	BSP031	3 Allen
D316 - D320	TC044 M6	TA020-1	TC038 M5x12	BK020	BY040	BSP030	3 Allen

95° MWLNR

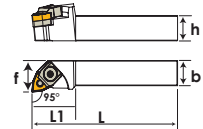

Sipariş Kodu	Ürün Kodu	Ölçüler (mm)						Uç	Fiyat
		L	L1	h	f	b	kg		
D182	MWLNR 2020 K08	125	32	20	25	20	0,435		₺703
D184	MWLNR 2525 M08	150	32	25	32	25	0,761	WNMG 0804	₺725
D185	MWLNR 3232 P08	170	32	32	40	32	1,349	ISO.	₺829

Kod	TC044 M6	TA020	BSP021	BK026	BY040	BSP030	3 Allen
	TC044 M6	TA020	BSP021	BK026	BY040	BSP030	3 Allen

95° MWLNL

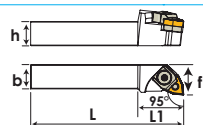
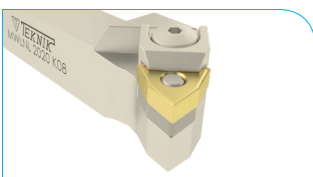

Sipariş Kodu	Ürün Kodu	Ölçüler (mm)						Uç	Fiyat
		L	L1	h	f	b	kg		
D322	MWLNL 2020 K08	125	32	20	25	20	0,435		₺703
D324	MWLNL 2525 M08	150	32	25	32	25	0,761	WNMG 0804	₺725
D326	MWLNL 3232 P08	170	32	32	40	32	1,349	ISO.	₺829

Kod	TC044 M6	TA020	BSP021	BK026	BY040	BSP030	3 Allen
	TC044 M6	TA020	BSP021	BK026	BY040	BSP030	3 Allen

95 MWMNN

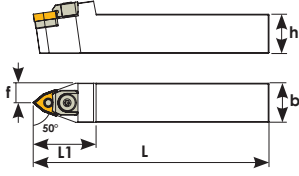
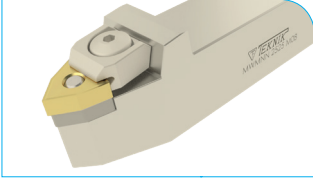

Sipariş Kodu	Ürün Kodu	Ölçüler (mm)						Uç	Fiyat
		L	L1	h	f	b			
D114	MWMNN 2020 K08	125	40	20	10	20	0,432	WNMG 0804	₺703
D116	MWMNN 2525 M08	150	40	25	12.5	25	0,724	ISO.	₺725

TC044 M6	TA020	BSP021	BK026	BY040	BSP030	3 Allen	

93° MTJNR

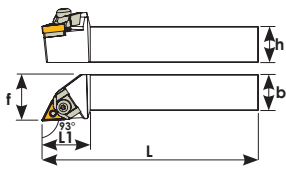
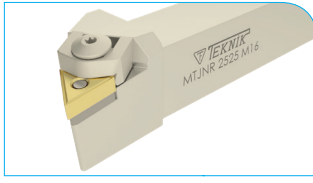

Sipariş Kodu	Ürün Kodu	Ölçüler (mm)						Uç	Fiyat
		L	L1	h	f	b			
D194	MTJNR 2020 K16	125	35	20	25	20	0,429	TNMG 1604	₺703
D196	MTJNR 2525 M16	150	35	25	32	25	0,760	ISO.	₺725
D198	MTJNR 3232 P16	170	35	32	40	32	1,360		₺829
D200	MTJNR 2020 K22	125	37	20	25	20	0,429	TNMG 2204	₺767
D202	MTJNR 2525 M22	150	40	25	32	25	0,775	ISO.	₺788
D204	MTJNR 3232 P22	170	40	32	40	32	1,348		₺871

Kod								
D194 - D198	TC046 M5	TA019	BSP020	BK022	BY043	BSP031	3 Allen	
D200 - D204	TC044 M6	TA045	BSP021	BK023	BY040	BSP030	3 Allen	

93° MTJNL

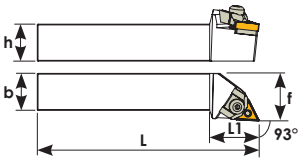
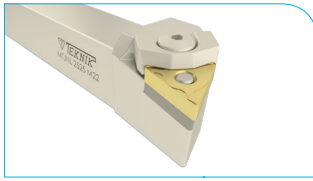

Sipariş Kodu	Ürün Kodu	Ölçüler (mm)						Uç	Fiyat
		L	L1	h	f	b			
D332	MTJNL 2020 K16	125	35	20	25	20	0,429		₺703
D334	MTJNL 2525 M16	150	35	25	32	25	0,760	TNMG 1604	₺725
D336	MTJNL 3232 P16	170	35	32	40	32	1,360	ISO.	₺829
D338	MTJNL 2020 K22	125	37	20	25	20	0,429	TNMG 2204	₺767
D340	MTJNL 2525 M22	150	40	25	32	25	0,775	ISO.	₺788
D342	MTJNL 3232 P22	170	40	32	40	32	1,348		₺871

Kod								
D332 - D336	TC046 M5	TA019	BSP020	BK022	BY043	BSP031	3 Allen	
D338 - D342	TC044 M6	TA045	BSP021	BK023	BY040	BSP030	3 Allen	

60° MTENN

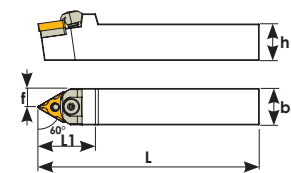
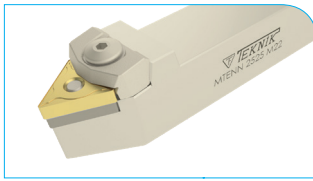

Sipariş Kodu	Ürün Kodu	Ölçüler (mm)						Uç	Fiyat
		L	L1	h	f	b			
D108	MTENN 2020 K16	125	35	20	10	20	0,408	TNMG 1604	₺703
D110	MTENN 2525 M16	150	35	25	12.5	25	0,724	ISO.	₺725
D112	MTENN 2525 M22	150	40	25	12.5	25	0,734	TNMG 2204	₺788
D113	MTENN 3232 P22	170	40	32	16	32	1,311	ISO.	₺871

Kod								
D108 - D110	TC046 M5	TA019	BSP020	BK022	BY043	BSP031	3 Allen	
D112 - D113	TC044 M6	TA045	BSP021	BK023	BY040	BSP030	3 Allen	

93° DVJNR

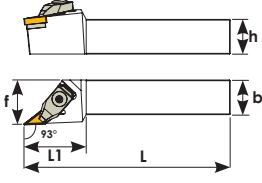

Sipariş Kodu	Ürün Kodu	Ölçüler (mm)						Uç	Fiyat
		L	L1	h	f	b	kg		
D105-1	DVJNR 2020 K16	125	40	20	27	20	0,428	VNMG 1604	₺703
D105	DVJNR 2525 M16	150	40	25	32	25	0,427	ISO.	₺725

TC046 M5	TA033	TC074 M4x10	BK021	BY043	BSP031	3 Allen	

93° DVJNL

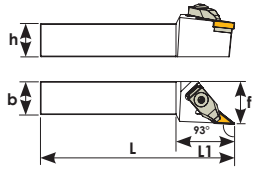
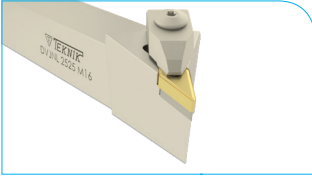

Sipariş Kodu	Ürün Kodu	Ölçüler (mm)						Uç	Fiyat
		L	L1	h	f	b	kg		
D343	DVJNL 2020 K16	125	40	20	27	20	0,428	VNMG 1604	₺703
D344	DVJNL 2525 M16	150	40	25	32	25	0,427	ISO.	₺725

TC046 M5	TA033	TC074 M4x10	BK021	BY043	BSP031	3 Allen	

72,5° DVVNN

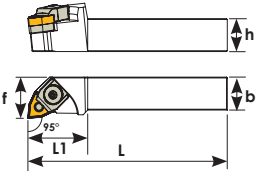
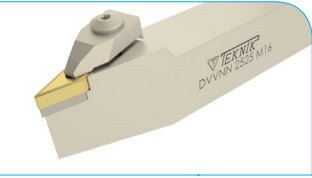

Sipariş Kodu	Ürün Kodu	Ölçüler (mm)						Uç	Fiyat
		L	L1	h	f	b	kg		
D105-2	DVVNN 2525 M16	150	45	25	12,5	25	0,690	VNMG 1604	₺725

TC046 M5	TA033	TC074 M4x10	BK021	BY043	BSP031	3 Allen	

Kalite için **TEKNIK** çözüm
Technical solution for quality

THE **TEKNIK MAKİNA**[®]
EXCEPTIONAL
CUTTING TOOLS
COLLECTION

TEKNIK

www.teknikmakinatakim.com



S Sistem Dış Çap Kater



www.teknikcuttingtools.com



Kalite için TEKNİK çözüm

Technical solution for quality

88-94



95° SCLCR

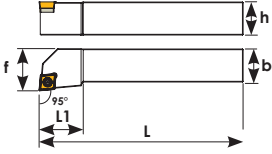

Sipariş Kodu	Ürün Kodu	Ölçüler (mm)						Uç	Fiyat
		L	L1	h	f	b			
D398	SCLCR 1010 J06	110	10	10	12	10	0,105	CCMT 0602 ISO.	₺456
D400	SCLCR 1212 J09	110	16	12	16	12	0,140		₺456
D401	SCLCR 1616 H09	100	20	16	20	16	0,215	CCMT 09T3	₺495
D402	SCLCR 2020 K09	125	25	20	25	20	0,425	ISO.	₺563
D403	SCLCR 2525 M09	150	25	25	32	25	0,772		₺580
D418	SCLCR 2020 K12	125	25	20	25	20	0,421	CCMT 1204	₺623
D403-1	SCLCR 2525 M12	150	25	25	32	25	0,768	ISO.	₺663

Kod				
D398	TC060 M2,5x5,5	--	--	T8
D400	TC067 M3,5x8,5	--	--	T15
D401-D403	TC068 M3,5x11	TA015	TC048 M5	T15
D418-D403-1	TC075 M4x11	TA015-1	TC049-1 M6	T15

95° SCLCL

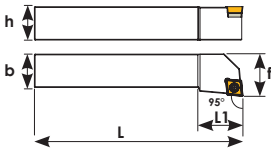
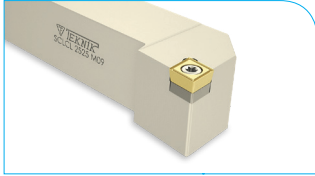

Sipariş Kodu	Ürün Kodu	Ölçüler (mm)						Uç	Fiyat
		L	L1	h	f	b			
D404	SCLCL 1010 J06	110	10	10	12	10	0,105	CCMT 0602	₺456
D405	SCLCL 1212 J09	110	16	12	16	12	0,140	ISO.	₺456
D406	SCLCL 1616 H09	100	20	16	20	16	0,215	CCMT 09T3	₺495
D407	SCLCL 2020 K09	125	25	20	25	20	0,425	ISO.	₺563
D408	SCLCL 2525 M09	150	25	25	32	25	0,772		₺580
D420	SCLCL 2020 K12	125	25	20	25	20	0,421	CCMT 1204	₺623
D421	SCLCL 2525 M12	150	25	25	32	25	0,768	ISO.	₺663

Kod				
D404	TC060 M2,5x5,5	--	--	T8
D405	TC067 M3,5x8,5	--	--	T15
D406-D408	TC068 M3,5x11	TA015	TC048 M5	T15
D420-D421	TC075 M4x11	TA015-1	TC049-1 M6	T15

90° SCACR-F

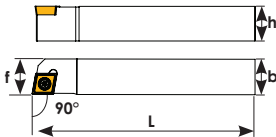

Sipariş Kodu	Ürün Kodu	Ölçüler (mm)				Uç	Fiyat	
		L	h	f	b			
D411	SCACR 1010 J06-F	110	10	10	10	0,104	CCMT 0602 ISO	₺456
D412	SCACR 1212 J09-F	110	12	12	12	0,143		₺456
D414	SCACR 1616 H09-F	100	16	16	16	0,221	CCMT 09T3	₺495
D416	SCACR 2020 K09-F	125	20	20	20	0,420	ISO.	₺563

Kod				
D411	TC060 M2,5x5,5	--	--	T8
D412	TC067 M3,5x11	--	--	T15
D414-D416	TC068 M3,5x11	TA015	TC048 M5	T15

95° SCLCR-F

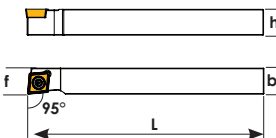
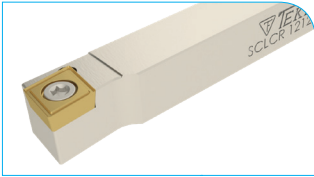

Sipariş Kodu	Ürün Kodu	Ölçüler (mm)				Uç	Fiyat	
		L	h	f	b			
D422	SCLCR 1010 J06-F	110	10	10	10	0,106	CCMT 0602	₺456
D424	SCLCR 1212 J06-F	110	12	12	12	0,147	ISO.	₺456
D426	SCLCR 1212 J09-F	110	12	12	12	0,144	CCMT 09T3	₺456
D428	SCLCR 1616 H09-F	100	16	16	16	0,224	ISO.	₺495
D430	SCLCR 2020 K09-F	125	20	20	20	0,426		₺563

Kod				
D422-D424	TC060 M2,5x5,5	--	--	T8
D426-D430	TC068 M3,5x11	--	--	T15
D428-D430	TC068 M3,5x11	TA015	TC048 M5	T15

93° SDJCR

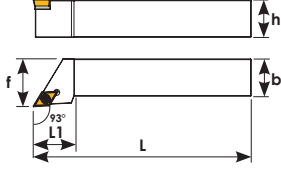

Sipariş Kodu	Ürün Kodu	Ölçüler (mm)						Uç	Fiyat																														
		L	L1	h	f	b	kg																																
D220	SDJCR 1010 J07	110	15	10	12	10	0,097	DCMT 0702 ISO	₺456																														
D222	SDJCR 1212 J11	110	20	12	16	12	0,132		₺456																														
D224	SDJCR 1616 H11	100	25	16	20	16	0,204	DCMT 11T3	₺495																														
D226	SDJCR 2020 K11	125	25	20	25	20	0,404	ISO.	₺563																														
D228	SDJCR 2525 M11	150	30	25	32	25	0,735		₺580																														
<p>Kod</p> <table border="0"> <tr> <td>D220</td> <td>TC060 M2,5x5,5</td> <td>---</td> <td></td> <td></td> <td></td> <td></td> <td></td> <td>T8</td> <td></td> </tr> <tr> <td>D222</td> <td>TC067 M3,5x8,5</td> <td>---</td> <td></td> <td></td> <td></td> <td></td> <td></td> <td></td> <td></td> </tr> <tr> <td>D224-D228</td> <td>TC068 M3,5x11</td> <td>TA030</td> <td></td> <td></td> <td></td> <td>TC048 M5</td> <td></td> <td>T15</td> <td></td> </tr> </table>										D220	TC060 M2,5x5,5	---						T8		D222	TC067 M3,5x8,5	---								D224-D228	TC068 M3,5x11	TA030				TC048 M5		T15	
D220	TC060 M2,5x5,5	---						T8																															
D222	TC067 M3,5x8,5	---																																					
D224-D228	TC068 M3,5x11	TA030				TC048 M5		T15																															

93° SDJCL

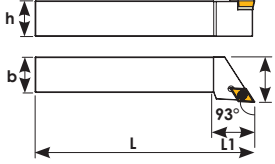
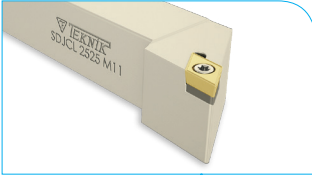

Sipariş Kodu	Ürün Kodu	Ölçüler (mm)						Uç	Fiyat																														
		L	L1	h	f	b	kg																																
D360	SDJCL 1010 J07	110	15	10	12	10	0,097	DCMT 0702 ISO	₺456																														
D362	SDJCL 1212 J11	110	20	12	16	12	0,132		₺456																														
D364	SDJCL 1616 H11	100	25	16	20	16	0,204	DCMT 11T3	₺495																														
D366	SDJCL 2020 K11	125	25	20	25	20	0,404	ISO.	₺563																														
D368	SDJCL 2525 M11	150	30	25	32	25	0,735		₺580																														
<p>Kod</p> <table border="0"> <tr> <td>D360</td> <td>TC060 M2,5x5,5</td> <td>---</td> <td></td> <td></td> <td></td> <td></td> <td></td> <td>T8</td> <td></td> </tr> <tr> <td>D362</td> <td>TC067 M3,5x8,5</td> <td>---</td> <td></td> <td></td> <td></td> <td></td> <td></td> <td></td> <td></td> </tr> <tr> <td>D366-D368</td> <td>TC068 M3,5x11</td> <td>TA030</td> <td></td> <td></td> <td></td> <td>TC048 M5</td> <td></td> <td>T15</td> <td></td> </tr> </table>										D360	TC060 M2,5x5,5	---						T8		D362	TC067 M3,5x8,5	---								D366-D368	TC068 M3,5x11	TA030				TC048 M5		T15	
D360	TC060 M2,5x5,5	---						T8																															
D362	TC067 M3,5x8,5	---																																					
D366-D368	TC068 M3,5x11	TA030				TC048 M5		T15																															

62,5° SDNCN

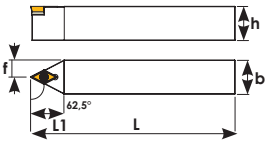

Sipariş Kodu	Ürün Kodu	Ölçüler (mm)						Uç	Fiyat																														
		L	L1	h	f	b	kg																																
D117	SDNCN 1010 J07	110	15	10	5	10	0,096	DCMT 0702 ISO	₺456																														
D118	SDNCN 1212 J11	110	25	12	6	12	0,131		₺456																														
D120	SDNCN 1616 H11	100	25	16	8	16	0,196	DCMT 11T3	₺495																														
D122	SDNCN 2020 K11	125	25	20	10	20	0,390	ISO.	₺563																														
D124	SDNCN 2525 M11	150	25	25	12,5	25	0,705		₺580																														
<p>Kod</p> <table border="0"> <tr> <td>D117</td> <td>TC060 M2,5x5,5</td> <td>---</td> <td></td> <td></td> <td></td> <td></td> <td></td> <td>T8</td> <td></td> </tr> <tr> <td>D118</td> <td>TC067 M3,5x8,5</td> <td>---</td> <td></td> <td></td> <td></td> <td></td> <td></td> <td></td> <td></td> </tr> <tr> <td>D120-D124</td> <td>TC068 M3,5x11</td> <td>TA030</td> <td></td> <td></td> <td></td> <td>TC048 M5</td> <td></td> <td>T15</td> <td></td> </tr> </table>										D117	TC060 M2,5x5,5	---						T8		D118	TC067 M3,5x8,5	---								D120-D124	TC068 M3,5x11	TA030				TC048 M5		T15	
D117	TC060 M2,5x5,5	---						T8																															
D118	TC067 M3,5x8,5	---																																					
D120-D124	TC068 M3,5x11	TA030				TC048 M5		T15																															

90° SDACR-F

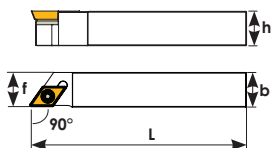

Sipariş Kodu	Ürün Kodu	Ölçüler (mm)						Uç	Fiyat																														
		L	L1	h	f	b	kg																																
D434	SDACR 1010 J07-F	110	10	10	10	10	0,970	DCMT 0702	₺456																														
D436	SDACR 1212 J07-F	110	12	12	12	12	0,135	ISO.	₺456																														
D438	SDACR 1616 H07-F	100	16	16	16	16	0,207		₺495																														
D440	SDACR 1212 J11-F	110	12	12	12	12	0,135		₺456																														
D442	SDACR 1616 H11-F	100	16	16	16	16	0,200	DCMT 11T3	₺495																														
D444	SDACR 2020 K11-F	125	20	20	20	20	0,397	ISO.	₺563																														
<p>Kod</p> <table border="0"> <tr> <td>D434-D438</td> <td>TC060 M2,5x5,5</td> <td>---</td> <td></td> <td></td> <td></td> <td></td> <td></td> <td>T8</td> <td></td> </tr> <tr> <td>D440</td> <td>TC067 M3,5x8,5</td> <td>---</td> <td></td> <td></td> <td></td> <td></td> <td></td> <td></td> <td></td> </tr> <tr> <td>D442-D444</td> <td>TC067 M3,5x8,5</td> <td>TA030</td> <td></td> <td></td> <td></td> <td>TC048 M5</td> <td></td> <td>T15</td> <td></td> </tr> </table>										D434-D438	TC060 M2,5x5,5	---						T8		D440	TC067 M3,5x8,5	---								D442-D444	TC067 M3,5x8,5	TA030				TC048 M5		T15	
D434-D438	TC060 M2,5x5,5	---						T8																															
D440	TC067 M3,5x8,5	---																																					
D442-D444	TC067 M3,5x8,5	TA030				TC048 M5		T15																															

93° SDJCR-F

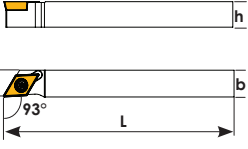

Sipariş Kodu	Ürün Kodu	Ölçüler (mm)					Uç	Fiyat
		L	h	f	b			
D452	SDJCR 1010 J07-F	110	10	10	10	0,103	DCMT 0702	₺456
D454	SDJCR 1212 J07-F	110	12	12	12	0,131	ISO.	₺456
D456	SDJCR 1616 H07-F	100	16	16	16	0,192		₺495
D457	SDJCR 1212 J11-F	110	12	12	12	0,134	DCMT 11T3 ISO.	₺456
Kod								
D452-D456		TC060 M2,5x5,5		T8				
D457		TC067 M3,5x8,5		T15				

107,5° SDHCR

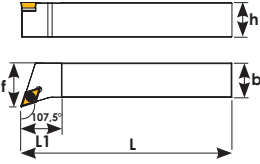

Sipariş Kodu	Ürün Kodu	Ölçüler (mm)						Uç	Fiyat
		L	L1	h	f	b			
D250	SDHCR 2020 K11	125	25	20	25	20	0,411	DCMT 11T3	₺563
D252	SDHCR 2525 M11	150	25	25	32	25	0,738	ISO.	₺580
Kod									
		TC068 M3,5x11	TA030	TC048 M5	T15				

107,5° SDHCL

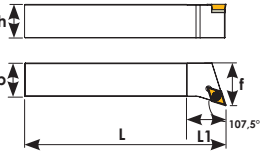

Sipariş Kodu	Ürün Kodu	Ölçüler (mm)						Uç	Fiyat
		L	L1	h	f	b			
D350	SDHCL 2020 K11	125	25	20	25	20	0,411	DCMT 11T3	₺563
D352	SDHCL 2525 M11	150	25	25	32	25	0,738	ISO.	₺580
Kod									
		TC068 M3,5x11	TA030	TC048 M5	T15				

93° SVJBR

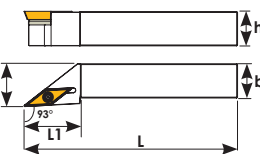

Sipariş Kodu	Ürün Kodu	Ölçüler (mm)						Uç	Fiyat
		L	L1	h	f	b			
D230	SVJBR 1010 J11	110	21	10	12	10	0,097	VBMT 1103	₺456
D232	SVJBR 1212 J11	110	21	12	16	12	0,141	ISO.	₺456
D234	SVJBR 1616 H11	100	25	16	20	16	0,192		₺495
D235	SVJBR 1616 H16	100	33	16	20	16	0,192	VBMT 1604	₺495
D236	SVJBR 2020 K16	125	33	20	25	20	0,382	ISO.	₺563
D238	SVJBR 2525 M16	150	40	25	32	25	0,688		₺580
D238-1	SVJBR 3232 P16	170	40	32	40	32	1,370		₺683
Kod									
D230-D234		TC061 M2,5x6,5	---	---	T8				
D235-D238-1		TC068 M3,5x11	TA034	TC048 M5	T15				

93° SVJBL

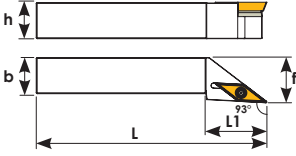
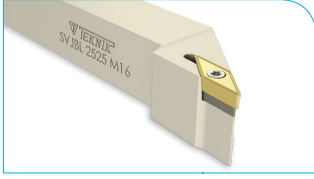

Sipariş Kodu	Ürün Kodu	Ölçüler (mm)						Uç	Fiyat
		L	L1	h	f	b			
D370	SVJBL 1010 J11	110	21	10	12	10	0,097	VBMT 1103	₺456
D372	SVJBL 1212 J11	110	21	12	16	12	0,141	ISO.	₺456
D373	SVJBL 1616 H11	100	25	16	20	16	0,192		₺495
D374	SVJBL 1616 H16	100	33	16	20	16	0,192	VBMT 1604	₺495
D380	SVJBL 2020 K16	125	33	20	25	20	0,382	ISO.	₺563
D382	SVJBL 2525 M16	150	40	25	32	25	0,688		₺580
D382-1	SVJBL 3232 P16	170	40	32	40	32	1,370		₺683
Kod									
D370-D373		TC061 M2,5x6,5	---	---	T8				
D374-D238-1		TC068 M3,5x11	TA034	TC048 M5		T15			

72,5° SVVBN

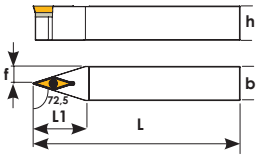

Sipariş Kodu	Ürün Kodu	Ölçüler (mm)						Uç	Fiyat
		L	L1	h	f	b			
D131	SVVBN 1212 J11	110	25	12	6	12	0,129	VBMT 1103 ISO	₺456
D132	SVVBN 1616 H16	100	33	16	8	16	0,184	VBMT 1604	₺495
D138	SVVBN 2020 K16	125	35	20	10	20	0,370	ISO.	₺563
D140	SVVBN 2525 M16	150	40	25	12,5	25	0,668		₺580
D141	SVVBN 3232-P16	170	40	32	40	32	1,386		₺683
Kod									
D131		TC061 M2,5x6,5	---	---	T8				
D132-D141		TC068 M3,5x11	TA034	TC048 M5		T15			

107,5° SVHBR

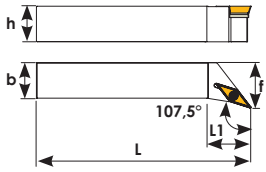

Sipariş Kodu	Ürün Kodu	Ölçüler (mm)						Uç	Fiyat
		L	L1	h	f	b			
D354-1	SVHBR 2020 K16	125	30	20	25	20	0,387	VBMT 1604	₺563
D356-1	SVHBR 2525 M16	150	30	25	32	25	0,712	ISO.	₺580
Kod									
D354-1		TC068 M3,5x11	TA034	TC048 M5		T15			

107,5° SVHBL

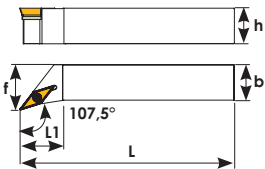
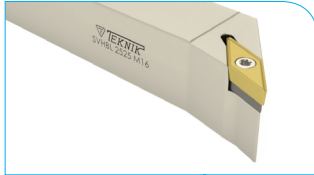

Sipariş Kodu	Ürün Kodu	Ölçüler (mm)						Uç	Fiyat
		L	L1	h	f	b			
D355	SVHBL 2020 K16	125	30	20	25	20	0,387	VBMT 1604	₺563
D356-2	SVHBL 2525 M16	150	30	25	32	25	0,712	ISO.	₺580
Kod									
D355		TC068 M3,5x11	TA034	TC048 M5		T15			

93° SVJBR-F

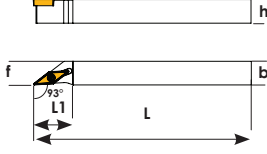
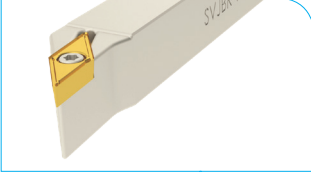

Sipariş Kodu	Ürün Kodu	Ölçüler (mm)						Uç	Fiyat
		L	L1	h	f	b			
D128	SVJBR 1010 J11-F	110	22	10	10	10	0,098		₺456
D129	SVJBR 1212 J11-F	110	22	12	12	12	0,132	VBMT 1103	₺456
D130	SVJBR 1616 H11-F	100	25	16	16	16	0,204	ISO.	₺495
Kod									
		TC061 M2,5x6,5		TA034		TC048 M5		T8	

93° SVJBL-F

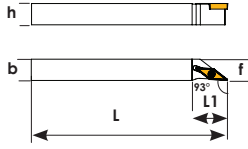

Sipariş Kodu	Ürün Kodu	Ölçüler (mm)						Uç	Fiyat
		L	L1	h	f	b			
D395	SVJBL 1010 J11-F	110	22	10	10	10	0,098		₺456
D396	SVJBL 1212 J11-F	110	22	12	12	12	0,132	VBMT 1103	₺456
D397	SVJBL 1616 H11-F	100	25	16	16	16	0,204	ISO.	₺495
Kod									
		TC061 M2,5x6,5		TA034		TC048 M5		T8	

93° SVJCR

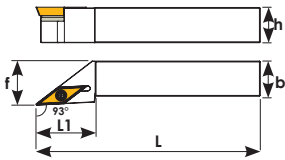

Sipariş Kodu	Ürün Kodu	Ölçüler (mm)						Uç	Fiyat
		L	L1	h	f	b			
D239	SVJCR 1010 J11	110	21	10	12	10	0,086		₺456
D240	SVJCR 1212 J11	110	21	12	16	12	0,135	VCMT 1103	₺456
D241	SVJCR 1616 H11	100	25	16	20	16	0,204	ISO.	₺495
D242	SVJCR 2020 K11	125	33	20	25	20	0,378		₺563
D243	SVJCR 2525 M11	150	40	25	32	25	0,738		₺580
D244	SVJCR 1616 H16	100	33	16	20	16	0,195	VCMT 1604	₺495
D246	SVJCR 2020 K16	125	33	20	25	20	0,385	ISO.	₺563
D248	SVJCR 2525 M16	150	40	25	32	25	0,683		₺580
D249	SVJCR 3232 P16	170	50	32	40	32	1,284		₺683
Kod									
		D239-D243 TC061 M2,5x6,5		TA034	TC048 M5	T8			
		D244-D249 TC068 M3,5x11		TA034	TC048 M5	T15			

93° SVJCL

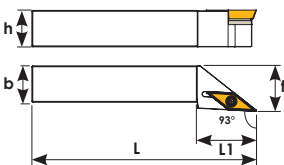
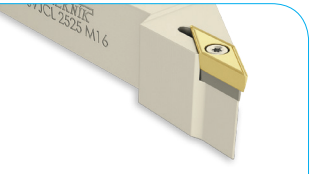

Sipariş Kodu	Ürün Kodu	Ölçüler (mm)						Uç	Fiyat
		L	L1	h	f	b			
D383	SVJCL 1010 J11	110	21	10	12	10	0,086		₺456
D384	SVJCL 1212 J11	110	21	12	16	12	0,135	VCMT 1103	₺456
D385	SVJCL 1616 H11	100	25	16	20	16	0,204	ISO.	₺495
D386	SVJCL 2020 K11	125	33	20	25	20	0,378		₺563
D387	SVJCL 2525 M11	150	40	25	32	25	0,738		₺580
D388	SVJCL 1616 H16	100	33	16	20	16	0,195	VCMT 1604	₺495
D390	SVJCL 2020 K16	125	33	20	25	20	0,385	ISO.	₺563
D392	SVJCL 2525 M16	150	40	25	32	25	0,683		₺580
D393	SVJCL 3232 P16	170	50	32	40	32	1,284		₺683
Kod									
		D383-D387 TC061 M2,5x7		TA034	TC048 M5	T8			
		D388-D923 TC068 M3,5x11		TA034	TC048 M5	T15			

90° SVJCR -F

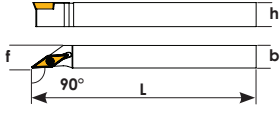

Sipariş Kodu	Ürün Kodu	Ölçüler (mm)					Uç	Fiyat
		L	h	f	b			
D460	SVJCR 1212 J11-F	110	12	12	12	0,134	VCMT 1103	₺456
D462	SVJCR 1616 H11-F	100	16	16	16	0,202	ISO.	₺495
		TC061 M2,5x6,5				T8		

72,5° SVVCN

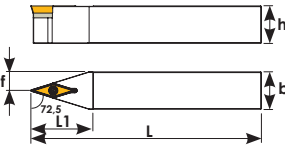
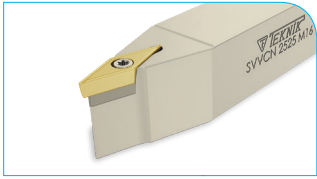

Sipariş Kodu	Ürün Kodu	Ölçüler (mm)						Uç	Fiyat
		L	L1	h	f	b			
D142	SVVCN 1212 J11	110	22	12	6	12	0,127	VCMT 1103 ISO	₺456
D144	SVVCN 1616 H16	100	35	16	8	16	0,187	VCMT 1604	₺495
D150	SVVCN 2020 K16	125	35	20	10	20	0,373	ISO.	₺563
D152	SVVCN 2525 M16	150	40	25	12,5	25	0,675		₺580
		D142	TC061 M2,5x6,5	---	---	T8			
		D144-D152	TC068 M3,5x11	TA034	TC048 M5	T15			

107,5° SVHCR

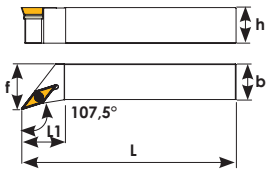
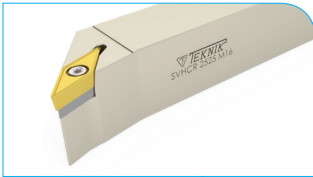

Sipariş Kodu	Ürün Kodu	Ölçüler (mm)					Uç	Fiyat	
		L	L1	h	f	b			
D254	SVHCR 2020 K16	125	30	20	25	20	0,384	VCMT 1604	₺563
D256	SVHCR 2525 M16	150	30	25	32	25	0,707	ISO.	₺580
		TC068 M3,5x11	TA034	TC048 M5				T15	

SVHCL

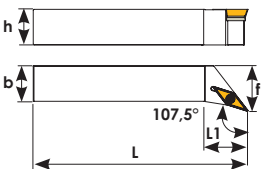

Sipariş Kodu	Ürün Kodu	Ölçüler (mm)					Uç	Fiyat	
		L	L1	h	f	b			
D354	SVHCL 2020 K16	125	30	20	25	20	0,384	VCMT 1604	₺563
D356	SVHCL 2525 M16	150	30	25	32	25	0,707	ISO.	₺580
		TC068 M3,5x11	TA034	TC048 M5				T15	

30° SRGCR

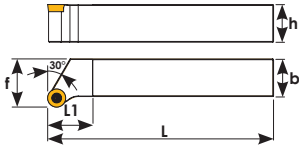
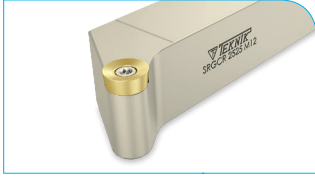

Sipariş Kodu	Ürün Kodu	Ölçüler (mm)						Uç	Fiyat
		L	L1	h	f	b			
D280	SRGCR 2020 K08	125	25	20	25	20	0,411	RCMT 0803	₺563
D282	SRGCR 2525 M08	150	30	25	32	25	0,710	ISO.	₺580
D284	SRGCR 2020 K10	125	25	20	25	20	0,410	RCMT 10T3	₺563
D286	SRGCR 2525 M10	150	30	25	32	25	0,720	ISO.	₺580
D288	SRGCR 2020 K12	125	25	20	25	20	0,422	RCMT 1204	₺563
D290	SRGCR 2525 M12	150	30	25	32	25	0,744	ISO.	₺580

Kod

D280-D282

TC065 M3x7

T8

D284-D290

TC067 M3,5x8,5

T15

30° SRGCL

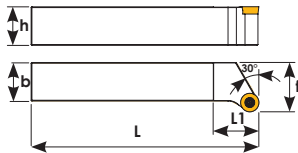
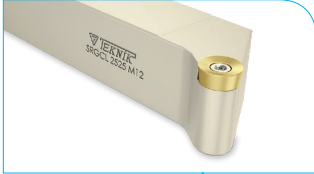

Sipariş Kodu	Ürün Kodu	Ölçüler (mm)						Uç	Fiyat
		L	L1	h	f	b			
D293	SRGCL 2020 K08	125	25	20	25	20	0,411	RCMT 0803	₺563
D294	SRGCL 2525 M08	150	30	25	32	25	0,710	ISO.	₺580
D283	SRGCL 2020 K10	125	25	20	25	20	0,410	RCMT 10T3	₺563
D292	SRGCL 2525 M10	150	30	25	32	25	0,720	ISO.	₺580
D281	SRGCL 2020 K12	125	25	20	25	20	0,422	RCMT 1204 ISO.	₺563
D291	SRGCL 2525 M12	150	30	25	32	25	0,744	ISO.	₺580

Kod

D293-D294

TC065 M3x7

T8

D283-D291

TC067 M3,5x8,5

T15

SRDCN

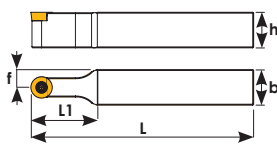

Sipariş Kodu	Ürün Kodu	Ölçüler (mm)						Uç	Fiyat
		L	L1	h	f	b			
D270	SRDCN 2020 K08	125	37	20	10	20	0,358	RCMT 0803	₺563
D271	SRDCN 2525 M08	150	37	25	12.5	25	0,653	ISO.	₺580
D272	SRDCN 2020 K10	125	35	20	10	20	0,370	RCMT 10T3	₺563
D274	SRDCN 2525 M10	150	35	25	12.5	25	0,670	ISO.	₺580
D276	SRDCN 2020 K12	125	33	20	10	20	0,372	RCMT 1204	₺563
D278	SRDCN 2525 M12	150	38	25	12.5	25	0,668	ISO.	₺580
D273	SRDCN 2525 M16	150	35	25	12.5	25	0,701	RCMT 1605 ISO.	₺580

Kod

D270-D271

TC065 M3x7

T8

D272-D278

TC067 M3,5x8,5



T15

D273

TC083 M5x12

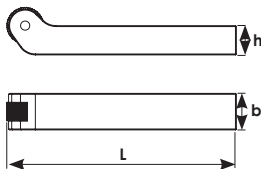
TIRTİL Kater



Sipariş Kodu	Ürün Kodu			Ölçüler (mm)			Fiyat	
				L	h	b		
P100	16-20 CNC TIRTİL	20x10x6	BSP041 6-23	125	16	20	0,351	₺623
P102	20-20 CNC TIRTİL	20x10x6	BSP041 6-18	125	20	20	0,427	₺623
P104	25-25 CNC TIRTİL	20x10x6	BSP040 6-23	150	25	25	0,600	₺663

P Sistem İç Çap Kater

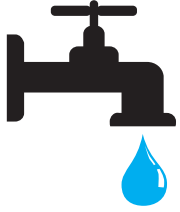

www.teknikcuttingtools.com



Kalite için TEKNİK çözüm







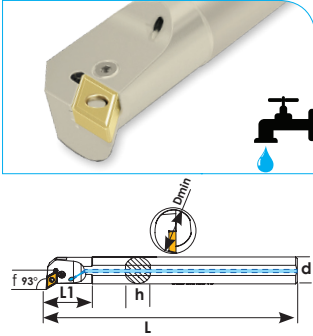

Technical solution for quality

96-99









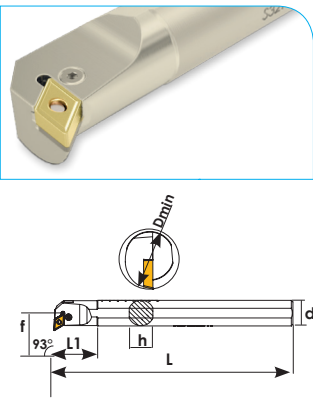

93° PDUNR IC
Soğutmalı



Sipariş Kodu	Ürün Kodu	Ölçüler (mm)							Uç	Fiyat
		Dmin	d	L	L1	f	h			
AP300	A25S PDUNR 15	32	25	250	50	17	23	0,900		₺1.183
AP302	A32T PDUNR 15	40	32	300	55	22	30	1,770	DNMG 1506	₺1.417
AP304	A40T PDUNR 15	50	40	300	55	27	38	1,790	ISO.	₺1.859
Kod										
AP300	TH6134	---	---	TL4A	2,5 Allen					
AP302 - AP304	TH822	TA014-1	TS-4	TL4B	3 Allen					







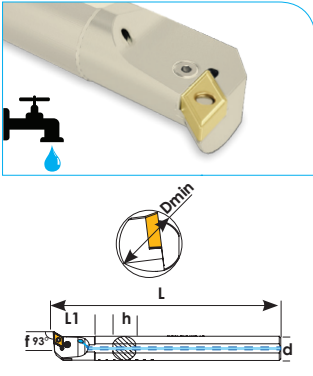

93° PDUNR



Sipariş Kodu	Ürün Kodu	Ölçüler (mm)							Uç	Fiyat
		Dmin	d	L	L1	f	h			
P300	S25S PDUNR 15	32	25	250	50	17	23	0,930		₺1.027
P302	S32T PDUNR 15	40	32	300	55	22	30	1,805	DNMG 1506	₺1.235
P304	S40T PDUNR 15	50	40	300	55	27	38	2,790	ISO.	₺1.625
Kod										
P300	TH6134	---	---	TL4A	TL4A					
P302 - P304	TH822	TA014-1	TS-4	TL4B	3 Allen					







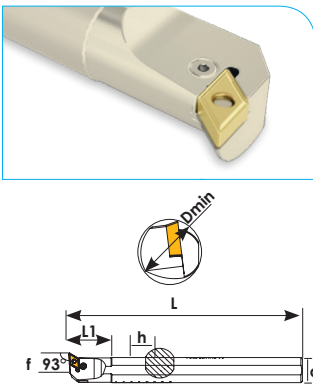

93° PDUNL IC
Soğutmalı



Sipariş Kodu	Ürün Kodu	Ölçüler (mm)							Uç	Fiyat
		Dmin	d	L	L1	f	h			
AP310	A25S PDUNL 15	32	25	250	50	17	23	0,900		₺1.183
AP312	A32T PDUNL 15	40	32	300	55	22	30	1,770	DNMG 1506	₺1.417
AP314	A40T PDUNL 15	50	40	300	55	27	38	1,790	ISO.	₺1.859
Kod										
AP310	TH6134	---	---	TL4A	2,5 Allen					
AP312 - AP314	TH822	TA014-1	TS-4	TL4B	3 Allen					

93° PDUNL



Sipariş Kodu	Ürün Kodu	Ölçüler (mm)							Uç	Fiyat
		Dmin	d	L	L1	f	h			
P310	S25S PDUNL 15	32	25	250	50	17	23	0,930		₺1.027
P312	S32T PDUNL 15	40	32	300	55	22	30	1,805	DNMG 1506	₺1.235
P314	S40T PDUNL 15	50	40	300	55	27	38	2,790	ISO.	₺1.625
Kod										
P310	TH6134	---	---	TL4A	TL4A					
P312 - P314	TH822	TA014-1	TS-4	TL4B	3 Allen					

95° PCLNR IC Soğutmalı

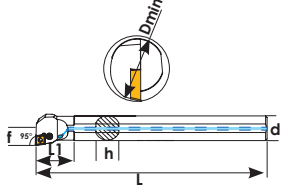

Sipariş Kodu	Ürün Kodu	Ölçüler (mm)							Uç	Fiyat
		Dmin	d	L	L1	f	h			
AP338	A20R PCLNR 12	24	20	200	50	13	18	0,520		₺988
AP340	A25S PCLNR 12	32	25	250	50	17	23	0,921	CNMG 1204	₺1.183
AP342	A32T PCLNR 12	40	32	300	50	22	30	1,809	ISO.	₺1.417
AP344	A40T PCLNR 12	50	40	300	55	27	38	1,820		₺1.859
Kod										
AP338-AP340		TH6134	---	---	---	---	---	TL4A	2,5 Allen	
AP342-AP344		TH821	TA016-1	---	---	---	---	TL4	3 Allen	

95° PCLNR

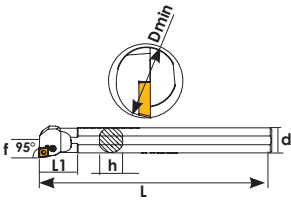
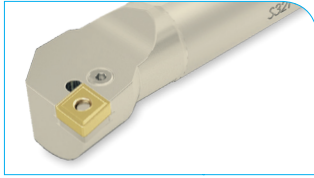

Sipariş Kodu	Ürün Kodu	Ölçüler (mm)							Uç	Fiyat
		Dmin	d	L	L1	f	h			
P338	S20R PCLNR 12	24	20	200	50	13	18	0,540		₺858
P340	S25S PCLNR 12	32	25	250	50	17	23	0,978	CNMG 1204	₺1.027
P342	S32T PCLNR 12	40	32	300	50	22	30	1,815	ISO.	₺1.235
P344	S40T PCLNR 12	50	40	300	55	27	38	1,825		₺1.625
Kod										
P338 - P340		TH6134	---	---	---	---	---	TL4A	2,5 Allen	
P342 - P344		TH821	TA016-1	---	---	---	---	TL4	3 Allen	

95° PCLNL IC Soğutmalı

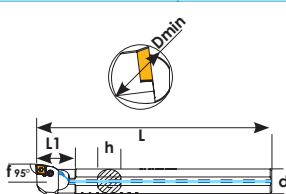
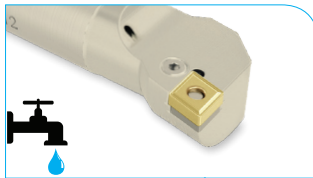

Sipariş Kodu	Ürün Kodu	Ölçüler (mm)							Uç	Fiyat
		Dmin	d	L	L1	f	h			
AP348	A20R PCLNL 12	24	20	200	50	13	18	0,520		₺988
AP350	A25S PCLNL 12	32	25	250	50	17	23	0,921	CNMG 1204	₺1.183
AP352	A32T PCLNL 12	40	32	300	50	22	30	1,809	ISO.	₺1.417
AP354	A40T PCLNL 12	50	40	300	55	27	38	1,820		₺1.859
Kod										
AP348-AP350		TH6134	---	---	---	---	---	TL4A	2,5 Allen	
AP352-AP354		TH821	TA016-1	---	---	---	---	TL4	3 Allen	

95° PCLNL

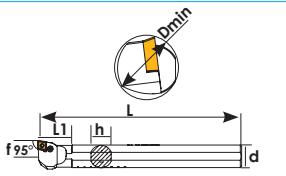

Sipariş Kodu	Ürün Kodu	Ölçüler (mm)							Uç	Fiyat
		Dmin	d	L	L1	f	h			
P348	S20R PCLNL 12	24	20	200	50	13	18	0,540		₺858
P350	S25S PCLNL 12	32	25	250	50	17	23	0,978	CNMG 1204	₺1.027
P352	S32T PCLNL 12	40	32	300	50	22	30	1,815	ISO.	₺1.235
P354	S40T PCLNL 12	50	40	300	55	27	38	1,825		₺1.625
Kod										
P348 - P350		TH6134	---	---	---	---	---	TL4A	2,5 Allen	
P352 - P354		TH821	TA016-1	---	---	---	---	TL4	3 Allen	

95° PWLNR 08 IC Soğutmalı

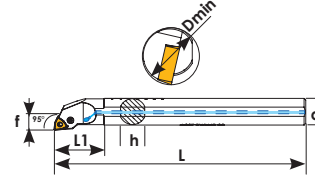
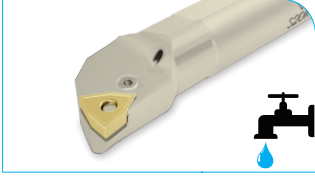

Sipariş Kodu	Ürün Kodu	Ölçüler (mm)							Uç	Fiyat
		Dmin	d	L	L1	f	h			
AP360	A25S PWLNR 08	32	25	250	50	17	23	0,911		₺1.183
AP362	A32T PWLNR 08	40	32	300	60	22	30	1,764	WNMG 0804	₺1.417
AP364	A40T PWLNR 08	50	40	300	60	27	38	2,800	ISO.	₺1.859
<p>Kod </p> <p>AP360 TH6134 --- --- TL4A 2,5 Allen</p> <p>AP362 - P364 TH821 TA020-1 TS-4 TL4 3 Allen</p>										

95° PWLNR 08

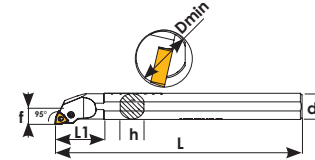
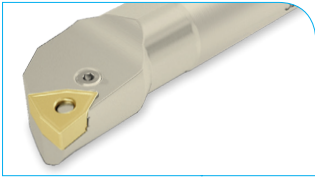

Sipariş Kodu	Ürün Kodu	Ölçüler (mm)							Uç	Fiyat
		Dmin	d	L	L1	f	h			
P360	S25S PWLNR 08	32	25	250	50	17	23	0,911		₺1.027
P362	S32T PWLNR 08	40	32	300	60	22	30	1,764	WNMG 0804	₺1.235
P364	S40T PWLNR 08	50	40	300	60	27	38	2,450	ISO.	₺1.625
<p>Kod </p> <p>P360 TH6134 --- --- TL4A 2,5 Allen</p> <p>P362 - P364 TH821 TA020-1 TS-4 TL4 3 Allen</p>										

95° PWLNL 08 IC Soğutmalı

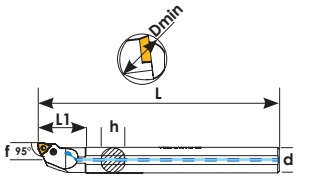

Sipariş Kodu	Ürün Kodu	Ölçüler (mm)							Uç	Fiyat
		Dmin	d	L	L1	f	h			
AP370	A25S PWLNL 08	32	25	250	50	17	23	0,911		₺1.183
AP372	A32T PWLNL 08	40	32	300	60	22	30	1,764	WNMG 0804	₺1.417
AP374	A40T PWLNL 08	50	40	300	60	27	38	2,800	ISO.	₺1.859
<p>Kod </p> <p>AP370 TH6134 --- --- TL4A 2,5 Allen</p> <p>AP372 - P374 TH821 TA020-1 TS-4 TL4 3 Allen</p>										

95° PWLNL 08

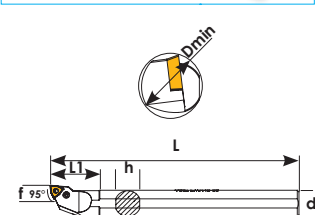
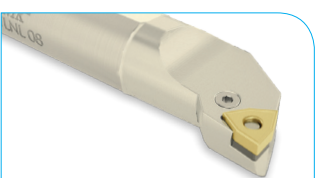

Sipariş Kodu	Ürün Kodu	Ölçüler (mm)							Uç	Fiyat
		Dmin	d	L	L1	f	h			
P370	S25S PWLNL 08	32	25	250	50	17	23	0,911		₺1.027
P372	S32T PWLNL 08	40	32	300	60	22	30	1,764	WNMG 0804	₺1.235
P374	S40T PWLNL 08	50	40	300	60	27	38	2,450	ISO.	₺1.625
<p>Kod </p> <p>P370 TH6134 --- --- TL4A 2,5 Allen</p> <p>P372 - P374 TH821 TA020-1 TS-4 TL4 3 Allen</p>										

95° PwLNR 06 IC
Soğutmalı

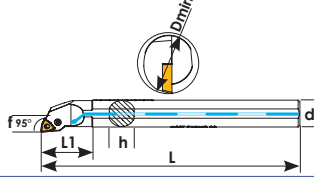
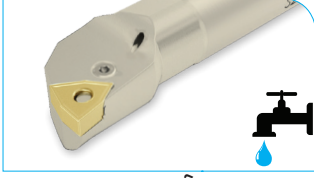

Sipariş Kodu	Ürün Kodu	Ölçüler (mm)							Uç	Fiyat
		Dmin	d	L	L1	f	h			
AP380	A16R PwLNR 06	20	16	200	40	11	15	0,326	WNMG 0604	₺988
AP382	A20R PwLNR 06	25	20	200	40	13	18	0,471	ISO.	₺988

TH512 M5
 TL3B
 2 Allen

95° PwLNR 06

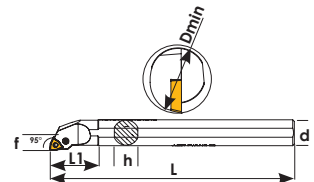
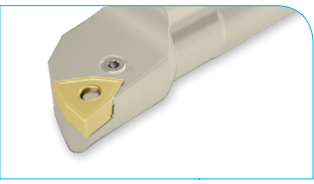

Sipariş Kodu	Ürün Kodu	Ölçüler (mm)							Uç	Fiyat
		Dmin	d	L	L1	f	h			
P380	S16R PwLNR 06	20	16	200	40	11	15	0,316	WNMG 0604	₺858
P382	S20R PwLNR 06	25	20	200	40	13	18	0,502	ISO.	₺858

TH512 M5
 TL3B
 2 Allen

95° PwLNL 06 IC
Soğutmalı

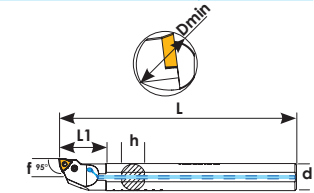
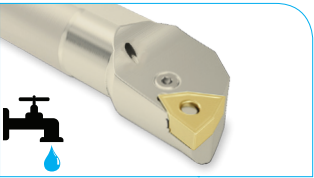

Sipariş Kodu	Ürün Kodu	Ölçüler (mm)							Uç	Fiyat
		Dmin	d	L	L1	f	h			
AP388	A16R PwLNL 06	20	16	200	40	11	15	0,326	WNMG 0604	₺988
AP390	A20R PwLNL 06	25	20	200	40	13	18	0,471	ISO.	₺988

TH512 M5
 TL3B
 2 Allen

95° PwLNL 06

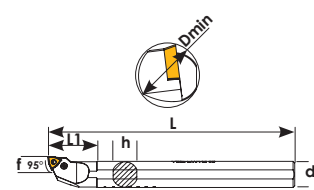
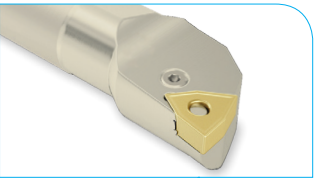

Sipariş Kodu	Ürün Kodu	Ölçüler (mm)							Uç	Fiyat
		Dmin	d	L	L1	f	h			
P388	S16R PwLNL 06	20	16	200	40	11	15	0,316	WNMG 0604	₺858
P390	S20R PwLNL 06	25	20	200	40	13	18	0,502	ISO.	₺858

TH512 M5
 TL3B
 2 Allen

Kalite için TEKNİK çözüm
Technical solution for quality



D-M Sistem İç Çap Kater



www.teknikcuttingtools.com



Kalite için TEKNİK çözüm
Technical solution for quality

102-105



93° DDUNR

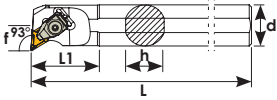
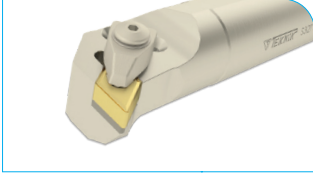

Sipariş Kodu	Ürün Kodu	Ölçüler (mm)							Uç	Fiyat
		Dmin	d	L	L1	f	h	kg		
K408	S20R DDUNR 11	30	20	200	50	13	18	0,508	DNMG 1104	₺858
K409	S25S DDUNR 11	32	25	250	50	17	23	0,956	ISO.	₺1.027
K410	S25S DDUNR 15	32	25	250	50	17	23	0,950		₺1.027
K412	S32T DDUNR 15	40	32	300	55	22	30	1,835		₺1.235
K414	S40T DDUNR 15	50	40	300	60	27	38	2,848		₺1.625
K415	S40U DDUNR 15	50	40	350	60	27	38	3,336	DNMG 1506	₺1.755
K416	S50U DDUNR 15	63	50	350	65	35	47	5,153	ISO.	₺2.002
K417	S50X DDUNR 15	63	50	550	65	35	47	8,716		₺2.535
K417-1	S60X DDUNR 15	73	60	600	65	37,5	57	13,66		₺3.705
K411	S25S DDUNR 15	32	25	250	50	17	23	0,958	DNMG 1504	₺1.027
K413	S32T DDUNR 15	40	32	300	55	22	30	1,830	ISO.	₺1.235

Kod

K408 - K409 TC046 M5 TA013 TC034 M3x7 BK024 BY041 BSP031 3 Allen

K410 - K413 TC044 M6 TA014-1 TC038 M4x10 BK020 BY040 BSP030 3 Allen

93° DDUNL

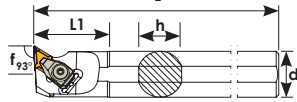
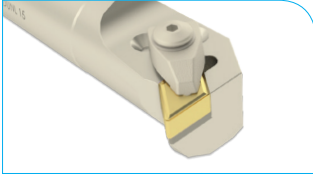

Sipariş Kodu	Ürün Kodu	Ölçüler (mm)							Uç	Fiyat
		Dmin	d	L	L1	f	h	kg		
K487	S20R DDUNL 11	30	20	200	50	13	18	0,508	DNMG 1104	₺858
K488	S25S DDUNL 11	32	25	250	50	17	23	0,956	ISO.	₺1.027
K490	S25S DDUNL 15	32	25	250	50	17	23	0,950		₺1.027
K492	S32T DDUNL 15	40	32	300	55	22	30	1,835	DNMG 1506	₺1.235
K494	S40T DDUNL 15	50	40	300	60	27	38	2,848	ISO.	₺1.625
K495	S40U DDUNL 15	50	40	350	60	27	38	3,336		₺1.755
K496	S50U DDUNL 15	63	50	350	65	35	47	5,153		₺2.002

Kod

K487 - K488 TC046 M5 TA013 TC034 M3x7 BK024 BY041 BSP031 3 Allen

K490 - K496 TC044 M6 TA014-1 TC038 M4x10 BK020 BY040 BSP030 3 Allen

107,5° DDQNR

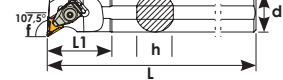
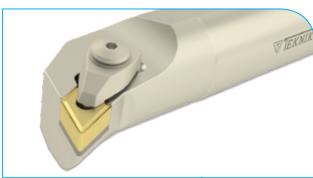

Sipariş Kodu	Ürün Kodu	Ölçüler (mm)							Uç	Fiyat
		Dmin	d	L	L1	f	h	kg		
K476	S25S DDQNR 15	32	25	250	50	17	23	0,935		₺1.027
K477	S32T DDQNR 15	40	32	300	60	22	30	1,805	DNMG 1506	₺1.235
K478	S40T DDQNR 15	50	40	300	60	27	38	2,786	ISO.	₺1.625
K479	S50U DDQNR 15	63	50	350	65	35	47	5,166		₺2.002

Kod

TC044 M6 TA014-1 TC038 M4x10 BK020 BY040 BSP030 3 Allen

107,5° DDQNL

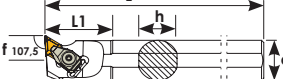
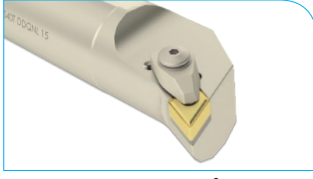

Sipariş Kodu	Ürün Kodu	Ölçüler (mm)							Uç	Fiyat
		Dmin	d	L	L1	f	h	kg		
K533	S25S DDQNL 15	32	25	250	50	17	23	0,935		₺1.027
K534	S32T DDQNL 15	40	32	300	60	22	30	1,805	DNMG 1506	₺1.235
K535	S40T DDQNL 15	50	40	300	60	27	38	2,786	ISO.	₺1.625
K536	S50U DDQNL 15	63	50	350	65	35	47	5,166		₺2.002

Kod

TC044 M6 TA014-1 TC038 M4x10 BK020 BY040 BSP030 3 Allen

93° MDUNR

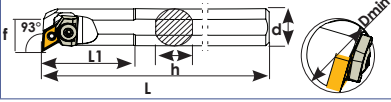
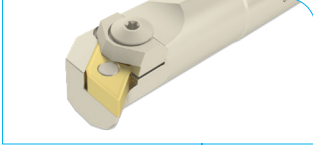

Sipariş Kodu	Ürün Kodu	Ölçüler (mm)							Uç	Fiyat
		Dmin	d	L	L1	f	h	kg		
K408-1	S20R MDUNR 11	25	20	200	50	13	18	0,508	DNMG 1104 ISO.	₺858

62,5° DDWNR

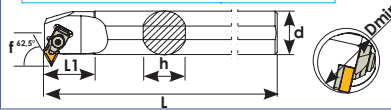
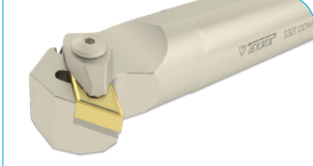

Sipariş Kodu	Ürün Kodu	Ölçüler (mm)							Uç	Fiyat
		Dmin	d	L	L1	f	h	kg		
K464	S32T DDWNR 15	40	32	300	55	24	30	1,859		₺1.235
K466	S40T DDWNR 15	50	40	300	50	30	38	2,918	DNMG 1506	₺1.625
K468	S50U DDWNR 15	63	50	350	60	35	47	5,298	ISO.	₺2.002

60° MTENR

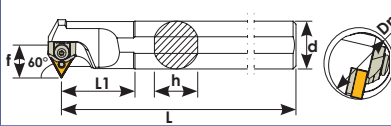
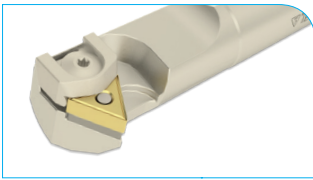

Sipariş Kodu	Ürün Kodu	Ölçüler (mm)							Uç	Fiyat
		Dmin	d	L	L1	f	h	kg		
K456	S25S MTENR 16	32	25	250	55	17	23	0,960		₺858
K458	S32T MTENR 16	40	32	300	60	22	30	1,842	TNMG 1604	₺1.235
K460	S40T MTENR 16	50	40	300	60	27	38	2,802	ISO.	₺1.625
K462	S50U MTENR 16	63	50	350	70	35	47	5,125		₺2.002

93° MTUNR

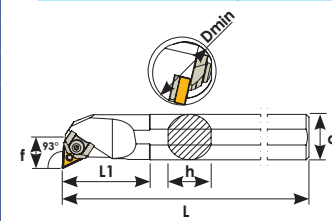
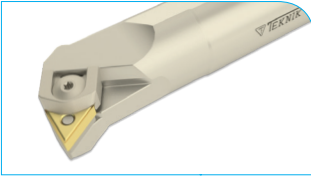

Sipariş Kodu	Ürün Kodu	Ölçüler (mm)							Uç	Fiyat																									
		Dmin	d	L	L1	f	h	kg																											
K441	S20R MTUNR 16	25	20	200	50	13	18	0,513		₺858																									
K442	S25S MTUNR 16	32	25	250	50	17	23	0,952	TNMG 1604	₺1.027																									
K444	S32T MTUNR 16	40	32	300	60	22	30	1,835	ISO.	₺1.235																									
K446	S40T MTUNR 16	50	40	300	60	27	38	2,852		₺1.625																									
K448	S50U MTUNR 16	63	50	350	65	35	47	5,150		₺2.002																									
K450	S32T MTUNR 22	40	32	300	60	22	30	1,836	TNMG 2204	₺1.235																									
K452	S40T MTUNR 22	50	40	300	60	27	38	2,814	ISO.	₺1.625																									
K454	S50U MTUNR 22	63	50	350	65	35	47	5,145		₺2.002																									
<p>Kod</p> <table border="0"> <tr> <td>K411</td> <td>TC043 M5</td> <td>---</td> <td>BSP019</td> <td>BK017-1</td> <td>BY041</td> <td>BSP031</td> <td>3 Allen</td> <td rowspan="3"></td> </tr> <tr> <td>K442 - K448</td> <td>TC046 M5</td> <td>TA019</td> <td>BSP020</td> <td>BK022</td> <td>BY043</td> <td>BSP031</td> <td>3 Allen</td> </tr> <tr> <td>K450 - K454</td> <td>TC044 M6</td> <td>TA045</td> <td>BSP021</td> <td>BK023</td> <td>BY040</td> <td>BSP030</td> <td>3 Allen</td> </tr> </table>											K411	TC043 M5	---	BSP019	BK017-1	BY041	BSP031	3 Allen		K442 - K448	TC046 M5	TA019	BSP020	BK022	BY043	BSP031	3 Allen	K450 - K454	TC044 M6	TA045	BSP021	BK023	BY040	BSP030	3 Allen
K411	TC043 M5	---	BSP019	BK017-1	BY041	BSP031	3 Allen																												
K442 - K448	TC046 M5	TA019	BSP020	BK022	BY043	BSP031	3 Allen																												
K450 - K454	TC044 M6	TA045	BSP021	BK023	BY040	BSP030	3 Allen																												

93° MTUNL

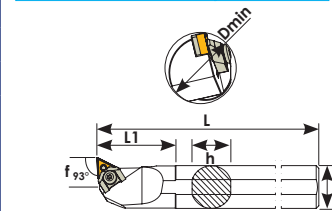
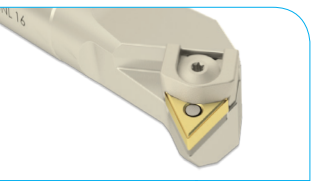

Sipariş Kodu	Ürün Kodu	Ölçüler (mm)							Uç	Fiyat																									
		Dmin	d	L	L1	f	h	kg																											
K519	S20R MTUNL 16	25	20	200	30	13	18	0,513		₺858																									
K520	S25S MTUNL 16	32	25	250	50	17	23	0,952	TNMG 1604	₺1.027																									
K522	S32T MTUNL 16	40	32	300	60	22	30	1,835	ISO.	₺1.235																									
K524	S40T MTUNL 16	50	40	300	60	27	38	2,852		₺1.625																									
K526	S50U MTUNL 16	63	50	350	65	35	47	5,150		₺2.002																									
K528	S32T MTUNL 22	40	32	300	60	22	30	1,836	TNMG 2204	₺1.235																									
K530	S40T MTUNL 22	50	40	300	60	27	38	2,814	ISO.	₺1.625																									
K532	S50U MTUNL 22	63	50	350	65	35	47	5,145		₺2.002																									
<p>Kod</p> <table border="0"> <tr> <td>K519</td> <td>TC043 M5</td> <td>---</td> <td>BSP019</td> <td>BK017-1</td> <td>BY041</td> <td>BSP031</td> <td>3 Allen</td> <td rowspan="3"></td> </tr> <tr> <td>K520 - K526</td> <td>TC046 M5</td> <td>TA019</td> <td>BSP020</td> <td>BK022</td> <td>BY043</td> <td>BSP031</td> <td>3 Allen</td> </tr> <tr> <td>K528 - K532</td> <td>TC044 M6</td> <td>TA045</td> <td>BSP021</td> <td>BK023</td> <td>BY040</td> <td>BSP030</td> <td>3 Allen</td> </tr> </table>											K519	TC043 M5	---	BSP019	BK017-1	BY041	BSP031	3 Allen		K520 - K526	TC046 M5	TA019	BSP020	BK022	BY043	BSP031	3 Allen	K528 - K532	TC044 M6	TA045	BSP021	BK023	BY040	BSP030	3 Allen
K519	TC043 M5	---	BSP019	BK017-1	BY041	BSP031	3 Allen																												
K520 - K526	TC046 M5	TA019	BSP020	BK022	BY043	BSP031	3 Allen																												
K528 - K532	TC044 M6	TA045	BSP021	BK023	BY040	BSP030	3 Allen																												

107,5° MTQNR

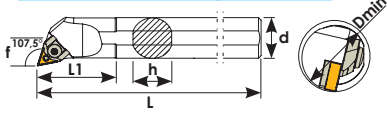

Sipariş Kodu	Ürün Kodu	Ölçüler (mm)							Uç	Fiyat
		Dmin	d	L	L1	f	h			
K365	S25S MTQNR 16	32	25	250	50	17	23	0,942		₺1.027
K366	S32T MTQNR 16	40	32	300	60	22	30	1,821	TNMG 1604	₺1.235
K367	S40T MTQNR 16	50	40	300	60	27	38	2,807	ISO.	₺1.625
K368	S50U MTQNR 16	63	50	350	65	35	47	5,121		₺2.002

107,5° MTQNL

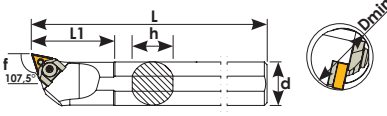
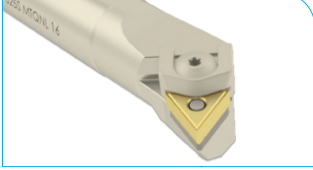

Sipariş Kodu	Ürün Kodu	Ölçüler (mm)							Uç	Fiyat
		Dmin	d	L	L1	f	h			
K537	S25S MTQNL 16	32	25	250	50	17	23	0,942		₺1.027
K538	S32T MTQNL 16	32	25	250	50	17	23	1,821	TNMG 1604	₺1.235
K539	S40T MTQNL 16	40	32	300	60	22	30	2,807	ISO.	₺1.625
K540	S50U MTQNL 16	50	40	300	60	27	38	5,121		₺2.002

95° MWLNR

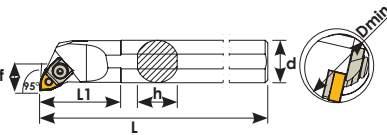
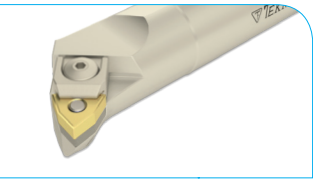

Sipariş Kodu	Ürün Kodu	Ölçüler (mm)							Uç	Fiyat
		Dmin	d	L	L1	f	h			
K427	S16Q MWLNR 06	21	16	180	40	11	15	0,286	WNMG 0604	₺858
K427-1	S20R MWLNR 06	25	20	200	50	13	18	0,502	ISO.	₺858
K428	S25S MWLNR 08	32	25	250	45	17	23	0,945		₺1.027
K430	S32T MWLNR 08	40	32	300	60	22	30	1,833	WNMG 0804	₺1.235
K432	S40T MWLNR 08	50	40	300	60	27	38	2,841	ISO.	₺1.625
K434	S50U MWLNR 08	63	50	350	65	35	47	5,110		₺2.002

95° MWLNL

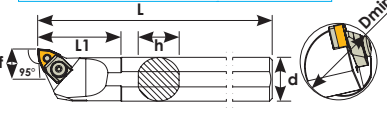
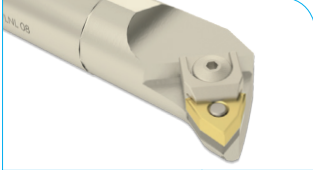

Sipariş Kodu	Ürün Kodu	Ölçüler (mm)							Uç	Fiyat
		Dmin	d	L	L1	f	h			
K510	S25S MWLNL 08	32	25	250	45	17	23	0,945		₺1.027
K512	S32T MWLNL 08	40	32	300	60	22	30	1,833	WNMG 0804	₺1.235
K514	S40T MWLNL 08	50	40	300	60	27	38	2,841	ISO.	₺1.625
K516	S50U MWLNL 08	63	50	350	65	35	47	5,110		₺2.002

95° DWLNR

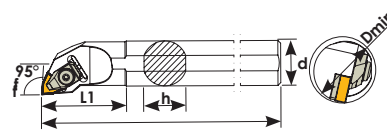
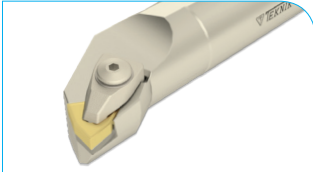

Sipariş Kodu	Ürün Kodu	Ölçüler (mm)							Uç	Fiyat
		Dmin	d	L	L1	f	h			
K418	S25S DWLNR 06	32	25	250	50	17	23	0,955	WNMG 0604 ISO	₺1.027
K420	S25S DWLNR 08	32	25	250	50	17	23	0,966		₺1.027
K422	S32T DWLNR 08	40	32	300	60	22	30	1,837	WNMG 0804	₺1.235
K424	S40T DWLNR 08	50	40	300	60	27	38	2,820	ISO.	₺1.625
K426	S50U DWLNR 08	63	50	350	75	35	47	5,123		₺2.002

95° DWLNL

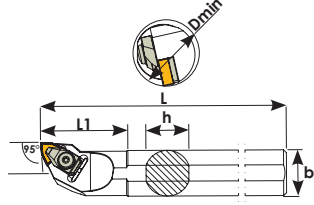
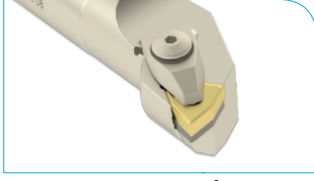

Sipariş Kodu	Ürün Kodu	Ölçüler (mm)							Uç	Fiyat
		Dmin	d	L	L1	f	h			
K498	S25S DWLNL 06	32	25	250	50	17	23	0,955	WNMG 0604 ISO	₺1.027
K500	S25S DWLNL 08	32	25	250	50	17	23	0,966	WNMG 0804	₺1.027
K502	S32T DWLNL 08	40	32	300	60	22	30	1,837	ISO.	₺1.235
K504	S40T DWLNL 08	50	40	300	60	27	38	2,820		₺1.625
K506	S50U DWLNL 08	63	50	350	75	35	47	5,123		₺2.002

Kod								
K498	TC046 M5	TA021	TC034 M3x7	BK024	BY041	BSP031	3 Allen	
K500 - K506	TC044 M6	TA020-1	TC038 M4x10	BK020	BY040	BSP030	3 Allen	

95° DCLNR

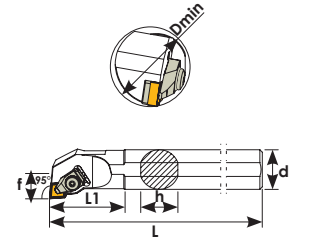

Sipariş Kodu	Ürün Kodu	Ölçüler (mm)							Uç	Fiyat
		Dmin	d	L	L1	f	h			
K400	S25S DCLNR 12	32	25	250	50	17	23	0,964		₺1.027
K402	S32T DCLNR 12	40	32	300	60	22	30	1,867	CNMG 1204	₺1.235
K404	S40T DCLNR 12	50	40	300	60	27	38	2,845	ISO.	₺1.625
K406	S50U DCLNR 12	63	50	350	60	35	47	5,166		₺2.002
K370	S32U DCLNR 16	40	32	350	60	22	30	2,272	CNMG 1606	₺1.300
K371	S40U DCLNR 16	50	40	350	60	27	38	3,550	ISO.	₺1.690
K374	S40U DCLNR 19	50	40	350	60	27	38	3,503	CNMG 1906	₺2.080
K375	S50V DCLNR 19	63	50	400	60	35	47	6,333	ISO.	₺2.275

Kod								
K400-K406	TC044 M6	TA016-1	TC038 M4x10	BK020	BY040	BSP030	3 Allen	
K370-K371	TC044 M6	TA022	TC095 M5x11,8	BK018			3 Allen	
K374-K375	TC048 M8	TA017	TC039 M6x12	BK025	BY044	BSP032		

95° DCLNL

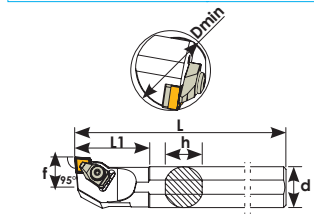
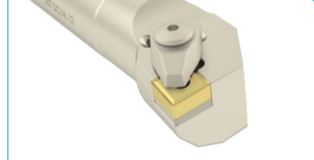

Sipariş Kodu	Ürün Kodu	Ölçüler (mm)							Uç	Fiyat
		Dmin	d	L	L1	f	h			
K480	S25S DCLNL 12	32	25	250	50	17	23	0,964		₺1.027
K482	S32T DCLNL 12	40	32	300	60	22	30	1,867	CNMG 1204	₺1.235
K484	S40T DCLNL 12	50	40	300	60	27	38	2,845	ISO.	₺1.625
K486	S50U DCLNL 12	63	60	350	75	35	47	5,166		₺2.002

TC044 M6	TA016-1	TC038 M4x10	BK020	BY040	BSP030	3 Allen	

75° DCKNR

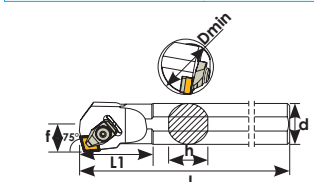
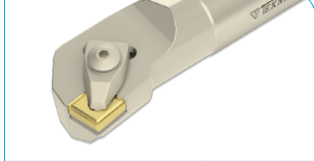

Sipariş Kodu	Ürün Kodu	Ölçüler (mm)							Uç	Fiyat
		Dmin	d	L	L1	f	h			
K401	S25S DCKNR 12	32	25	250	55	17	23	0,955		₺1.027
K403	S32T DCKNR 12	40	32	300	60	22	30	0,966	CNMG 1204	₺1.235
K405	S40T DCKNR 12	50	40	300	65	27	38	1,837	ISO.	₺1.625

TC044 M6	TA016-1	TC038 M4x10	BK020	BY040	BSP030	3 Allen	



Uç Baglama Sistemleri
Insert Clamping Systems
Wendeplatten klem systems



S Sistem İç Çap Kater

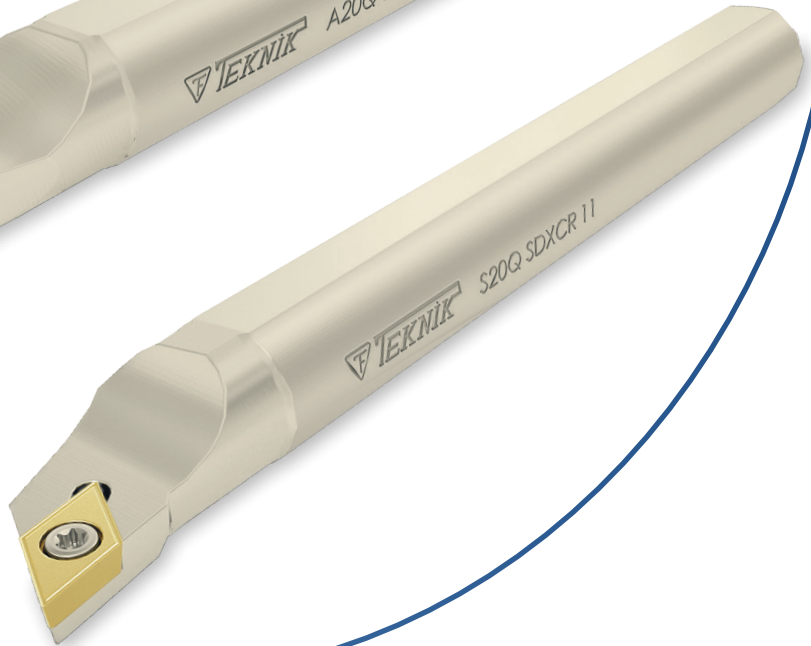
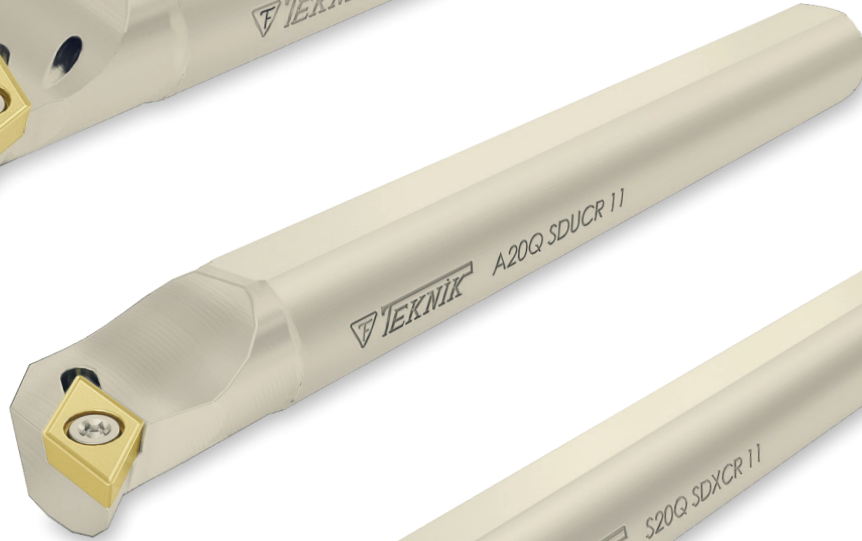
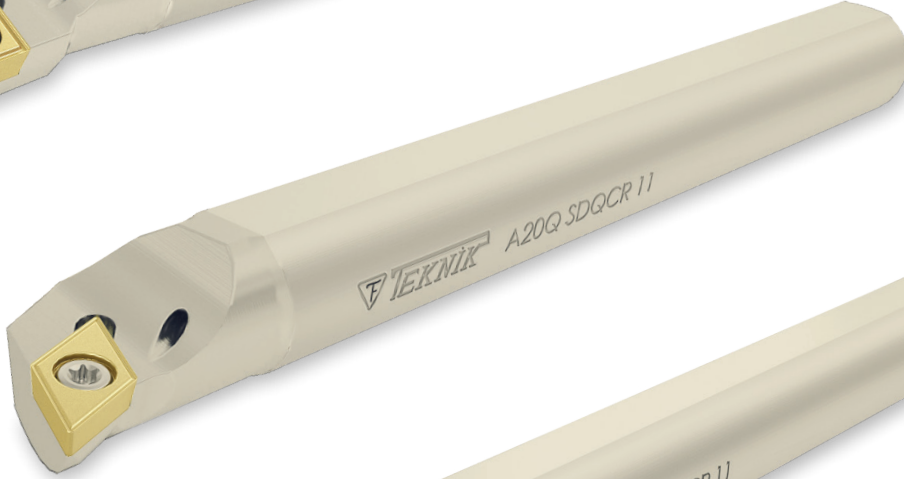
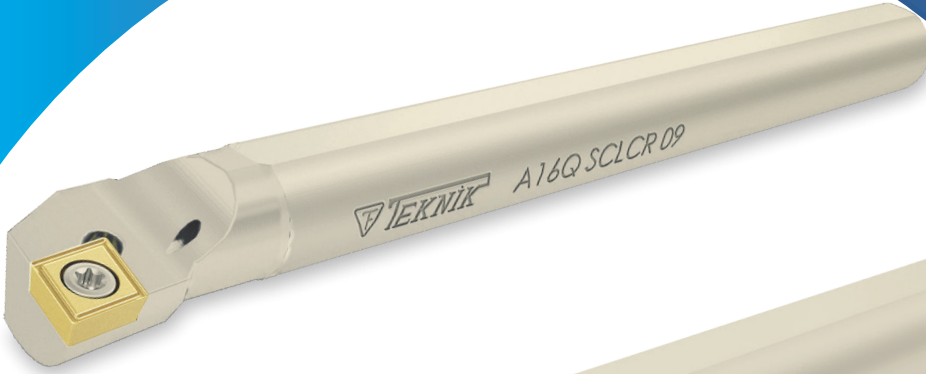
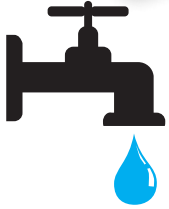

www.teknikcuttingtools.com



Kalite için TEKNİK çözüm
Technical solution for quality

108-115



95° SCLCR IC Soğutmalı

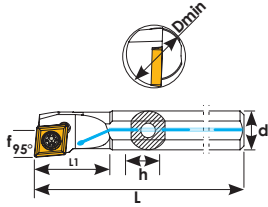

Sipariş Kodu	Ürün Kodu	Ölçüler (mm)								Uç	Fiyat
		Dmin	d	L	L1	f	h				
KA102	A08H SCLCR 06	10	8	100	16	5,5	7	0,050	CCMT 0602	₺395	
KA104	A10J SCLCR 06	12	10	110	20	6	9	0,074	ISO.	₺415	
KA106	A12K SCLCR 06	16	12	125	25	9	11	0,113		₺436	
KA108	A14-16Q SCLCR 09	18	16	180	45	9,5	15	0,267	CCMT 09T3	₺495	
KA110	A16Q SCLCR 09	20	16	180	30	11	15	0,260	ISO.	₺495	
KA111	A16M SCLCR 09	20	16	150	30	11	15	0,227		₺495	
KA114	A20Q SCLCR 09	25	20	180	40	13	18	0,422		₺547	
KA116	A25R SCLCR 09	32	25	200	40	17	23	0,734		₺728	
Kod											
KA102-KA106		TC060 M2,5x5,5				T8					
KA108 KA116		TC067 M3,5x8,5				T16					

95° SCLCR

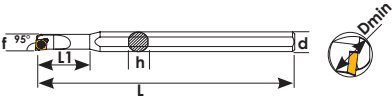
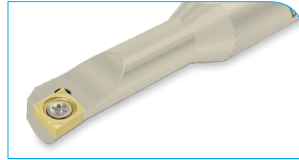

Sipariş Kodu	Ürün Kodu	Ölçüler (mm)								Uç	Fiyat
		Dmin	d	L	L1	f	h				
K097	S05-08H SCLCR 03	5	8	100	15	2,5	7,3	0,046	CCMT 0301	₺623	
K098	S06-08H SCLCR 03	6	8	100	18	3	7,3	0,048	ISO.	₺623	
K099	S07-08H SCLCR 04	7	8	100	21	3,5	7,3	0,050	CCMT 0401 ISO.	₺623	
Kod											
K097-K098		TC057 M1,6				T6					
K099		TC058 M2x4,2									

95° SCLCR

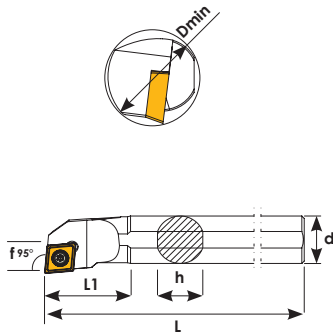
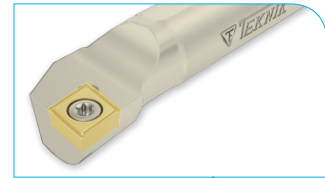

Sipariş Kodu	Ürün Kodu	Ölçüler (mm)								Uç	Fiyat
		Dmin	d	L	L1	f	h				
K100	S06-08H SCLCR 06	9	8	100	25	4,3	7,3	0,052		₺339	
K102	S08H SCLCR 06	10	8	100	16	5,5	7,3	0,053	CCMT 0602	₺339	
K104	S10J SCLCR 06	12	10	110	20	6	9	0,080	ISO.	₺363	
K105	S10K SCLCR 06	12	10	125	20	6	9	0,085		₺363	
K106	S12K SCLCR 06	16	12	125	25	9	11	0,120		₺374	
K107	S12Q SCLCR 06	16	12	180	25	9	11	0,170		₺436	
K107-1	S12K SCLCR 09	16	12	125	25	9	11	0,271		₺374	
K108	S14-16Q SCLCR 09	18	16	180	45	9,5	15	0,285		₺436	
K110	S16Q SCLCR 09	20	16	180	30	11	15	0,317		₺436	
K111	S16R SCLCR 09	20	16	200	30	11	15	0,329	CCMT 09T3	₺456	
K112	S18-20Q SCLCR 09	21	20	180	38	11	18	0,436	ISO.	₺478	
K114	S20Q SCLCR 09	25	20	180	40	13	18	0,612		₺478	
K115	S20S SCLCR 09	25	20	250	40	13	18	0,780		₺495	
K116	S25R SCLCR 09	32	25	200	40	17	23	0,694		₺637	
K117	S25T SCLCR 09	32	25	300	40	17	23	1,165		₺663	
K116-1	S25S SCLCR 12	32	25	250	45	17	23	0,965	CCMT 1204 ISO.	₺663	
Yedek Part											
K100-K102		TC059-1 M2,5x4,7				T8					
K104-K107		TC060 M2,5x5,5									
K107-1 K117		TC067 M3,5x8,5				T15					
K116-1		TC083 M5x12				T20					

95° SCLCL IC Soğutmalı

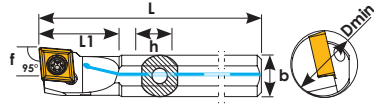

Sipariş Kodu	Ürün Kodu	Ölçüler (mm)							Uç	Fiyat
		Dmin	d	L	L1	f	h			
KA232	A08H SCLCL 06	10	8	100	16	5,5	7	0,050	CCMT 0602	₺395
KA234	A10J SCLCL 06	12	10	110	20	6	9	0,074	ISO.	₺415
KA236	A12K SCLCL 06	16	12	125	25	9	11	0,113		₺436
KA238	A14-16Q SCLCL 09	18	16	180	45	9,5	15	0,271		₺495
KA239	A16M SCLCL 09	20	16	150	30	11	15	0,227	CCMT 09T3	₺495
KA240	A16Q SCLCL 09	20	16	180	30	11	15	0,260	ISO.	₺495
KA244	A20Q SCLCL 09	25	20	180	40	13	18	0,422		₺547
KA246	A25R SCLCL 09	32	25	200	40	17	23	0,734		₺728

Kod

KA232-KA236 TC060 M2,5x5,5 T8
KA238-KA246 TC067 M3,5x8,5 T16

95° SCLCL

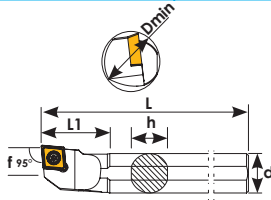
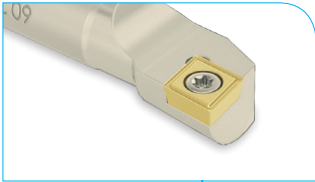

Sipariş Kodu	Ürün Kodu	Ölçüler (mm)							Uç	Fiyat
		Dmin	d	L	L1	f	h			
K230	S06-08H SCLCL 06	9	8	100	25	4,3	7	0,052		₺339
K232	S08H SCLCL 06	10	8	100	16	5,5	7	0,053	CCMT 0602	₺339
K234	S10J SCLCL 06	12	10	110	20	6	9	0,080	ISO.	₺363
K236	S12K SCLCL 06	16	12	125	25	9	11	0,120		₺374
K238	S14-16Q SCLCL 09	18	16	180	45	9,5	15	0,271		₺436
K240	S16Q SCLCL 09	20	16	180	30	11	15	0,285	CCMT 09T3	₺436
K241	S16R SCLCL 09	20	16	200	30	11	15	0,317	ISO.	₺456
K244	S20Q SCLCL 09	25	20	180	40	13	18	0,436		₺478
K245	S20S SCLCL 09	25	20	250	40	13	18	0,612		₺495
K246	S25R SCLCL 09	32	25	200	40	17	23	0,780		₺637

Kod

K230-K236 TC060 M2,5x5,5 T8
K238-K246 TC067 M3,5x8,5 T16

93° SDUCR IC Soğutmalı

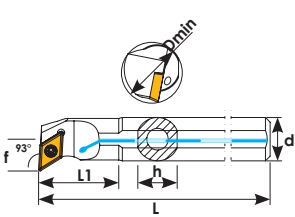
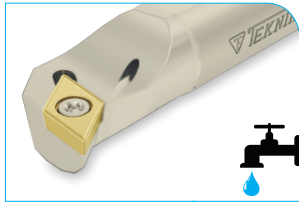

Sipariş Kodu	Ürün Kodu	Ölçüler (mm)							Uç	Fiyat
		Dmin	d	L	L1	f	h			
KA120	A10J SDUCR 07	12	10	110	20	7	9	0,080	DCMT 0702	₺415
KA122	A12K SDUCR 07	16	12	125	25	9	11	0,120	ISO.	₺436
KA124	A14-16Q SDUCR 07	18	16	180	40	10,5	15	0,267		₺495
KA126	A16Q SDUCR 07	20	16	180	30	11	15	0,263		₺495
KA127	A16M SDUCR 07	20	16	150	30	11	15	0,250		₺495
KA128	A16Q SDUCR 11	20	16	180	30	11	15	0,285		₺495
KA129	A16M SDUCR 11	20	16	150	30	11	15	0,246	DCMT 11T3	₺495
KA130	A20Q SDUCR 11	25	20	180	32	13	18	0,432	ISO.	₺547
KA132	A25R SDUCR 11	32	25	200	40	17	23	0,746		₺728
KA134	A32T SDUCR 11	40	32	300	45	22	30	1,924		₺1.131

Kod

KA120-KA127 TC060 M2,5x5,5 T8
KA128-KA134 TC067 M3,5x8,5 T15

93° SDUCR

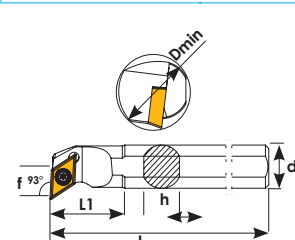

Sipariş Kodu	Ürün Kodu	Ölçüler (mm)							Uç	Fiyat
		Dmin	d	L	L1	f	h			
K120	S10J SDUCR 07	12	10	110	20	7	9	0,080		₺363
K122	S12K SDUCR 07	16	12	125	25	9	11	0,120	DCMT 0702	₺374
K123	S12Q SDUCR 07	16	12	180	25	9	11	0,170	ISO.	₺436
K124	S14-16Q SDUCR 07	18	16	180	40	10,5	15	0,266		₺436
K126	S16Q SDUCR 07	20	16	180	30	11	15	0,292		₺436
K125	S14-16Q SDUCR 11	18	16	180	45	10,5	15	0,272		₺436
K128	S16Q SDUCR 11	20	16	180	30	11,5	15	0,285	DCMT 11T3	₺436
K129	S16M SDUCR 11	20	16	150	30	11	15	0,246		₺436
K130	S20Q SDUCR 11	25	20	180	32	13	18	0,435	ISO.	₺478
K132	S25R SDUCR 11	32	25	200	40	17	23	0,748		₺637
K134	S32T SDUCR 11	40	32	300	45	22	30	1,833		₺975

Kod

K120-K126 TC060 M2,5x5,5 T8
K125-K134 TC067 M3,5x8,5 T15

93° SDUCL IC Soğutmalı

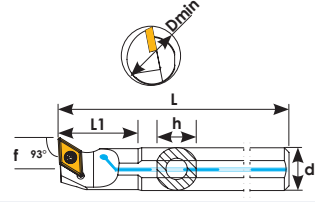
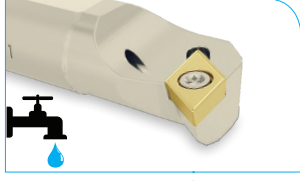

Sipariş Kodu	Ürün Kodu	Ölçüler (mm)								Uç	Fiyat
		Dmin	d	L	L1	f	h				
KA250	A10J SDUCL 07	12	10	110	20	7	9	0,080	DCMT 0702	₺415	
KA252	A12K SDUCL 07	16	12	125	25	9	11	0,120	ISO.	₺436	
KA254	A14-16Q SDUCL 07	18	16	180	40	10,5	15	0,267		₺495	
KA256	A16Q SDUCL 07	20	16	180	30	11	15	0,263		₺495	
KA258	A16Q SDUCL 11	20	16	180	30	11	15	0,285		₺495	
KA259	A16M SDUCL 11	20	16	150	30	11	15	0,246	DCMT 11T3	₺495	
KA260	A20Q SDUCL 11	25	20	180	32	13	18	0,432	ISO.	₺547	
KA262	A25R SDUCL 11	32	25	200	40	17	23	0,746		₺728	
KA263	A32T SDUCL 11	40	32	300	45	22	30	1,924		₺1.131	
Kod											
KA250-KA256		TC060 M2,5x5,5		TC067 M3,5x8,5		T8					
KA258-KA263		TC067 M3,5x8,5				T15					

93° SDUCL

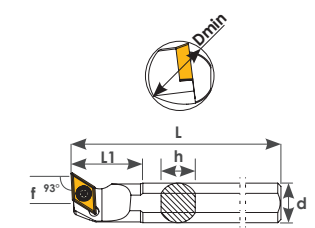
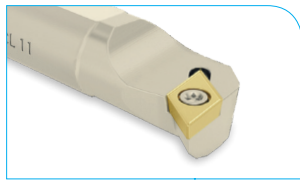

Sipariş Kodu	Ürün Kodu	Ölçüler (mm)								Uç	Fiyat
		Dmin	d	L	L1	f	h				
K250	S10J SDUCL 07	12	10	110	20	7	9	0,080		₺363	
K252	S12K SDUCL 07	16	12	125	25	9	11	0,120	DCMT 0702	₺374	
K254	S14-16Q SDUCL 07	18	16	180	40	10,5	15	0,266	ISO.	₺436	
K256	S16Q SDUCL 07	20	16	180	30	11	15	0,292		₺436	
K258	S16Q SDUCL 11	20	16	180	30	11	15	0,285	DCMT 11T3	₺436	
K259	A16M SDUCL 11	20	16	150	30	11	15	0,246		₺436	
K260	S20Q SDUCL 11	25	20	180	32	13	18	0,435	ISO.	₺478	
K262	S25R SDUCL 11	32	25	200	40	17	23	0,748		₺637	
K263	S32T SDUCL 11	40	32	300	45	22	30	1,833		₺975	
Kod											
K250-K256		TC060 M2,5x5,5		TC067 M3,5x8,5		T8					
K258-K263		TC067 M3,5x8,5				T15					

107,5° SDQCR IC Soğutmalı

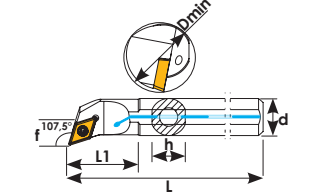
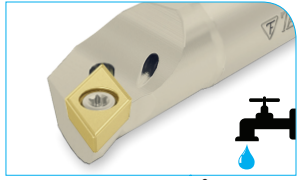

Sipariş Kodu	Ürün Kodu	Ölçüler (mm)								Uç	Fiyat
		Dmin	d	L	L1	f	h				
KA140	A10J SDQCR 07	12	10	110	20	7	9	0,074	DCMT 0702	₺415	
KA142	A12K SDQCR 07	16	12	125	25	9	11	0,110	ISO.	₺436	
KA143	A16M SDQCR 07	20	16	150	30	11	15	0,232		₺495	
KA144	A16Q SDQCR 07	20	16	180	30	11	15	0,282		₺495	
KA146	A16Q SDQCR 11	20	16	180	30	11	15	0,275		₺495	
KA148	A20Q SDQCR 11	25	20	180	32	13	18	0,425	DCMT 11T3	₺547	
KA150	A25R SDQCR 11	32	25	200	40	17	23	0,738	ISO.	₺728	
Kod											
KA140-KA144		TC060 M2,5x5,5		TC067 M3,5x8,5		T8					
KA146-KA150		TC067 M3,5x8,5				T15					

107,5° SDQCR

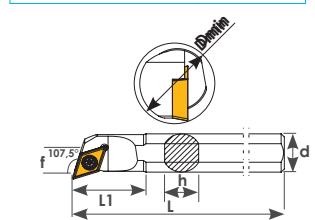

Sipariş Kodu	Ürün Kodu	Ölçüler (mm)								Uç	Fiyat
		Dmin	d	L	L1	f	h				
K140	S10J SDQCR 07	12	10	110	20	7	9	0,080	DCMT 0702	₺363	
K142	S12K SDQCR 07	16	12	125	25	9	11	0,120	ISO.	₺374	
K144	S16Q SDQCR 07	20	16	180	30	11	15	0,292		₺436	
K146	S16Q SDQCR 11	20	16	180	30	11	15	0,285		₺436	
K148	S20Q SDQCR 11	25	20	180	32	13	18	0,435	DCMT 11T3	₺478	
K150	S25R SDQCR 11	32	25	200	40	17	23	0,748	ISO.	₺637	
K152	S32T SDQCR 11	40	32	300	50	22	30	1,833		₺975	
K154	S40T SDQCR 11	50	40	300	50	27	38	0,268		₺1.430	
Kod											
K140-K144		TC060 M2,5x5,5		TC067 M3,5x8,5		T8					
K146-K154		TC067 M3,5x8,5				T15					

107,5° SDQCL IC Soğutmalı

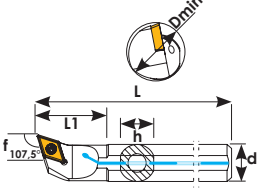

Sipariş Kodu	Ürün Kodu	Ölçüler (mm)							Uç	Fiyat
		Dmin	d	L	L1	f	h			
KA270	A10J SDQCL 07	12	10	110	20	7	9	0,074	DCMT 0702	₺415
KA272	A12K SDQCL 07	16	12	125	25	9	11	0,110	ISO.	₺436
KA273	A16M SDQCL 07	20	16	150	30	11	15	0,232		₺495
KA274	A16Q SDQCL 07	20	16	180	30	11	15	0,282		₺495
KA276	A16Q SDQCL 11	20	16	180	30	11	15	0,275	DCMT 11T3	₺495
KA278	A20Q SDQCL 11	25	20	180	32	13	18	0,425	ISO.	₺547
KA280	A25R SDQCL 11	32	25	200	40	17	23	0,738		₺728

Kod			
KA270-KA274	TC060 M2,5x5,5		T8
KA276-KA280	TC067 M3,5x8,5		T15

107,5° SDQCL

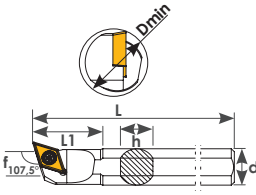
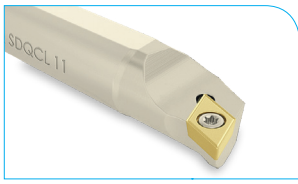

Sipariş Kodu	Ürün Kodu	Ölçüler (mm)							Uç	Fiyat
		Dmin	d	L	L1	f	h			
K270	S10J SDQCL 07	12	10	110	20	7	9	0,080	DCMT 0702	₺363
K272	S12K SDQCL 07	16	12	125	25	9	11	0,120	ISO.	₺374
K274	S16Q SDQCL 07	20	16	180	30	11	15	0,292		₺436
K276	S16Q SDQCL 11	20	16	180	30	11	15	0,285		₺436
K278	S20Q SDQCL 11	25	20	180	32	13	18	0,435	DCMT 11T3	₺478
K280	S25R SDQCL 11	32	25	200	40	17	23	0,748	ISO.	₺637
K281	S32T SDQCL 11	40	32	300	50	22	30	1,833		₺975

Kod			
K270-K274	TC060 M2,5x5,5		T8
K276-K281	TC067 M3,5x8,5		T15

120° SDXCR

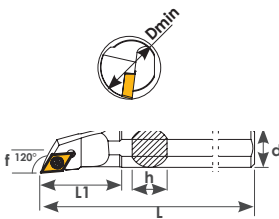
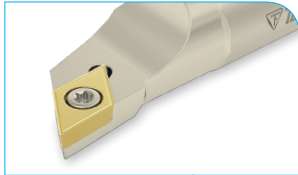

Sipariş Kodu	Ürün Kodu	Ölçüler (mm)							Uç	Fiyat
		Dmin	d	L	L1	f	h			
K469	S10J SDXCR 07	12	10	110	25	5,5	9	0,080	DCMT 0702	₺363
K470	S12K SDXCR 07	16	12	125	30	9	11	0,120	ISO.	₺374
K471	S16Q SDXCR 11	20	16	180	40	11	15	0,285		₺436
K472	S20Q SDXCR 11	25	20	180	40	13	18	0,435		₺478
K473	S25R SDXCR 11	32	25	200	50	13,5	23	0,748	DCMT 11T3	₺637
K474	S32T SDXCR 11	40	32	300	55	17	30	1,833	ISO.	₺975
K475	S40T SDXCR 11	50	40	300	55	21	38	0,268		₺1.430

Kod			
K469-K470	TC060 M2,5x5,5		T8
K471-K475	TC067 M3,5x8,5		T15

62,5° SD-CR

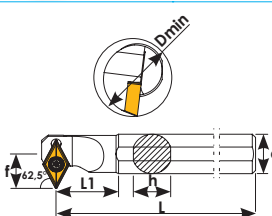
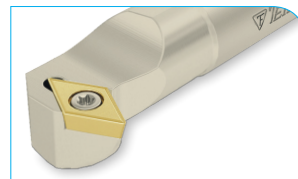



Sipariş Kodu	Ürün Kodu	Ölçüler (mm)							Uç	Fiyat
		Dmin	d	L	L1	f	h			
K168	S10J SD-CR 07	14	10	110	25	8,2	9	0,082	DCMT 0702	₺363
K170	S12K SD-CR 07	16	12	125	25	9	11	0,122	ISO.	₺374
K173	S16Q SD-CR 07	20	16	180	35	12	15	0,280		₺436
K172	S16Q SD-CR 11	23	16	180	35	14	15	0,288		₺436
K174	S20Q SD-CR 11	25	20	180	32	15	18	0,443	DCMT 11T3	₺478
K176	S25R SD-CR 11	32	25	200	35	17	23	0,771	ISO.	₺637
K178	S32T SD-CR 11	40	32	300	55	23	30	1,865		₺975

Kod			
K168-K173	TC060 M2,5x5,5		T8
K172-K178	TC067 M3,5x8,5		T15

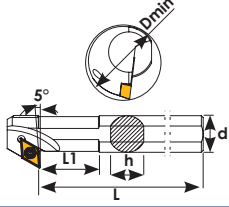
5° SDZCR





Sipariş Kodu	Ürün Kodu	Ölçüler (mm)							Uç	Fiyat
		Dmin	d	L	L1	f	h			
K190	S12K SDZCR 07	18	12	125	20	11	11	0,128	DCMT 0702 ISO	₺541
K192	S16Q SDZCR 11	23	16	180	25	14	15	0,302		₺602
K194	S20Q SDZCR 11	30	20	180	32	19	18	0,498	DCMT 11T3	₺663
K196	S25R SDZCR 11	35	25	200	32	22	23	0,816	ISO	₺793

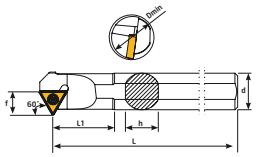
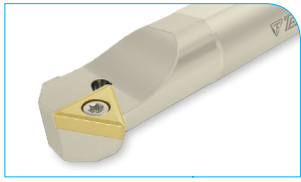

Kod  

K190	TC060 M2,5x5,5	T8	
K192-K196	TC067 M3,5x8,5	T15	

60° ST-CR





Sipariş Kodu	Ürün Kodu	Ölçüler (mm)							Uç	Fiyat
		Dmin	d	L	L1	f	h			
K180	S16Q ST-CR 16	20	16	180	40	11	15	0,817	TCMT 16T3	₺436
K182	S20Q ST-CR 16	25	20	180	40	13	18	0,432	ISO	₺478
K183	S25R ST-CR 16	32	25	200	50	17	23	0,772		₺637
K183-1	S32T ST-CR 16	30	32	300	60	22	30	1,961		₺975

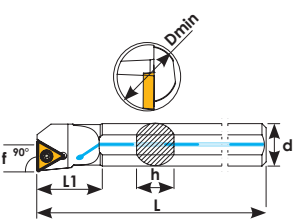
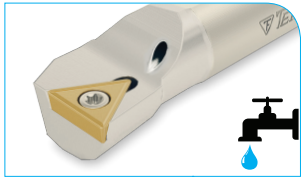

Kod  

	TC067 M3,5x8,5	T15	
--	----------------	-----	---

90° STFCR IC Soğutmalı





Sipariş Kodu	Ürün Kodu	Ölçüler (mm)							Uç	Fiyat
		Dmin	d	L	L1	f	h			
KA160	A12K STFCR 11	16	12	125	25	9	11	0,053	TCMT 1102	₺436
KA161	A16Q STFCR 11	20	16	180	30	11	15	0,289	ISO.	₺495
KA162	A16Q STFCR 16	20	16	180	30	11	15	0,287		₺495
KA164	A20Q STFCR 16	25	20	180	32	13	18	0,440	TCMT 16T3	₺547
KA166	A25R STFCR 16	32	25	200	40	16	23	0,754	ISO.	₺728

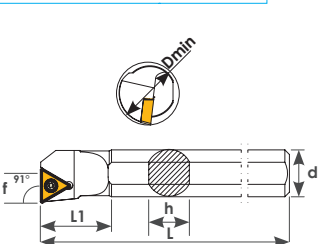
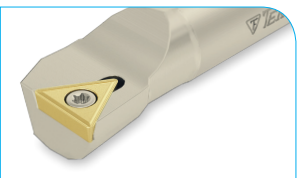

Kod  

KA160-KA161	TC060 M2,5x5,5	T8	
KA162 KA166	TC067 M3,5x8,5	T16	

90° STFCR



Sipariş Kodu	Ürün Kodu	Ölçüler (mm)							Uç	Fiyat
		Dmin	d	L	L1	f	h			
K160	S12K STFCR 11	16	12	125	25	9	11	0,118	TCMT 1102	₺374
K161	S16Q STFCR 11	20	16	180	30	11	15	0,290	ISO.	₺436
K162	S16Q STFCR 16	20	16	180	30	11	15	0,287	TCMT 16T3	₺436
K164	S20Q STFCR 16	25	20	180	32	13	18	0,440	ISO.	₺478
K166	S25R STFCR 16	32	25	200	40	16	23	0,773		₺637

Kod  

K160-K161	TC060 M2,5x5,5	T8	
K162-K166	TC067 M3,5x8,5	T15	

90° STFCL IC Soğutmalı

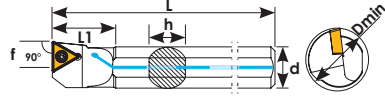

Sipariş Kodu	Ürün Kodu	Ölçüler (mm)							Uç	Fiyat
		Dmin	d	L	L1	f	h	kg		
KA184	A12K STFCL 11	16	12	125	25	9	11	0,053	TCMT 1102	₺436
KA185	A16Q STFCL 11	20	16	180	30	11	15	0,289	ISO.	₺495
KA186	A16Q STFCL 16	20	16	180	30	11	15	0,287		₺495
KA187	A20Q STFCL 16	25	20	180	32	13	18	0,440	TCMT 16T3	₺547
KA188	A25R STFCL 16	32	25	200	40	16	23	0,754	ISO.	₺728
Kod										
KA184-KA185		TC060 M2,5x5,5						T8		
KA186 KA188		TC067 M3,5x8,5						T16		

90° STFCL

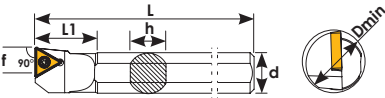
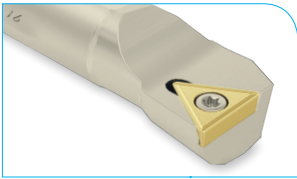

Sipariş Kodu	Ürün Kodu	Ölçüler (mm)							Uç	Fiyat
		Dmin	d	L	L1	f	h	kg		
K184	S12K STFCL 11	16	12	125	25	9	11	0,118	TCMT 1102	₺374
K185	S16Q STFCL 11	20	16	180	30	11	15	0,290	ISO.	₺436
K186	S16Q STFCL 16	20	16	180	30	11	15	0,287		₺436
K187	S20Q STFCL 16	25	20	180	32	13	18	0,440	TCMT 16T3	₺478
K188	S25R STFCL 16	32	25	200	40	16	23	0,773	ISO.	₺637
Kod										
K184-K185		TC060 M2,5x5,5						T8		
K186-K188		TC067 M3,5x8,5						T15		

93° SVUBR IC Soğutmalı

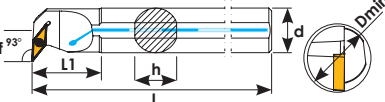
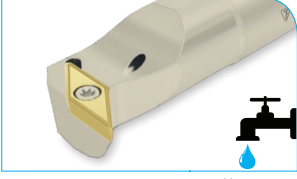

Sipariş Kodu	Ürün Kodu	Ölçüler (mm)							Uç	Fiyat
		Dmin	d	L	L1	f	h	kg		
KA208	A25R SVUBR 16	32	25	200	40	17	23	0,723	VBMT 1604	₺767
KA209	A32T SVUBR 16	40	32	300	50	22	30	1,909	ISO.	₺1.139
Kod										
		TC074 M4x10						T15		

93° SVUBR

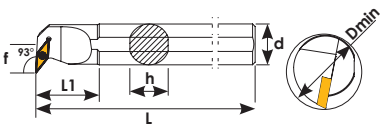
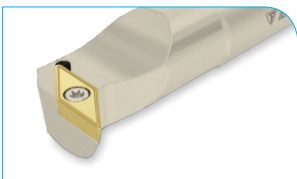

Sipariş Kodu	Ürün Kodu	Ölçüler (mm)							Uç	Fiyat
		Dmin	d	L	L1	f	h	kg		
K206	S16Q SVUBR 11	20	16	180	30	11	15	0,278	VBMT 1103	₺495
K207	S20Q SVUBR 11	25	20	180	32	13	18	0,700	ISO.	₺602
K208	S25R SVUBR 16	32	25	200	40	17	23	0,730		₺663
K209	S32T SVUBR 16	40	32	300	50	22	30	1,822	VBMT 1604	₺1.040
K210	S40T SVUBR 16	50	40	300	50	27	38	2,836	ISO.	₺1.430
Kod										
		TC061 M2,5x6,5						T8		
		TC074 M4x10						T15		

93° SVUBL IC Soğutmalı

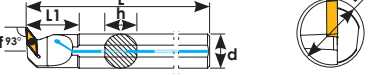

Sipariş Kodu	Ürün Kodu	Ölçüler (mm)							Uç	Fiyat
		Dmin	d	L	L1	f	h	kg		
KA286	A25R SVUBL 16	32	25	200	40	17	23	0,723	VBMT 1604	₺767
KA288	A32T SVUBL 16	40	32	300	50	22	30	1,909	ISO.	₺1.139
Kod										
		TC074 M4x10						T15		

93° SVUBL

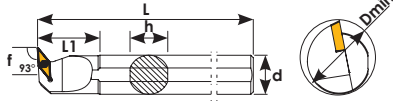
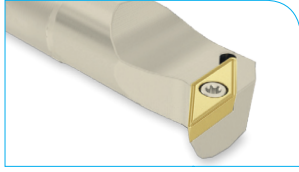

Sipariş Kodu	Ürün Kodu	Ölçüler (mm)							Uç	Fiyat
		Dmin	d	L	L1	f	h	kg		
K282	S16Q SVUBL 11	20	16	180	30	11	15	0,278	VBMT 1103	₺495
K284	S20Q SVUBL 11	25	20	180	32	13	18	0,700	ISO.	₺602
K286	S25R SVUBL 16	32	25	200	40	17	23	0,730	VBMT 1604	₺663
K288	S32T SVUBL 16	40	32	300	50	22	30	1,822	ISO.	₺1.040
Kod										
K282-K284		TC061 M2,5x6,5						T8		
K286-K288		TC074 M4x10						T15		

93° SVUCR IC Soğutmalı

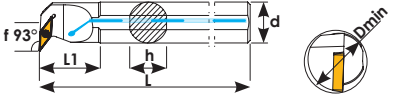
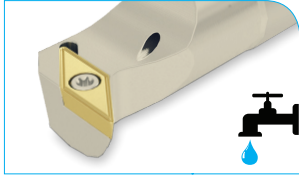

Sipariş Kodu	Ürün Kodu	Ölçüler (mm)							Uç	Fiyat
		Dmin	d	L	L1	f	h	kg		
KA211	A16Q SVUCR 11	20	16	180	30	11	15	0,268	VCMT 1103	₺573
KA212	A20Q SVUCR 11	25	20	180	32	13	18	0,689	ISO.	₺683
KA213	A25R SVUCR 16	32	25	200	40	17	23	0,720	VCMT 1604	₺767
KA214	A32T SVUCR 16	40	32	300	50	22	30	1,812	ISO.	₺1.139
Kod										
KA211-KA212		TC061 M2,5x6,5						T8		
KA213-KA214		TC074 M4x10						T15		

93° SVUCR

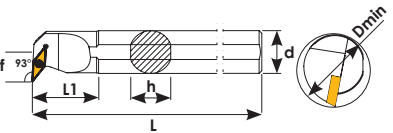
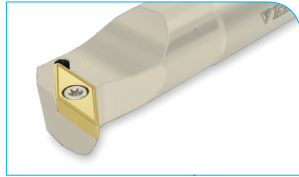

Sipariş Kodu	Ürün Kodu	Ölçüler (mm)							Uç	Fiyat
		Dmin	d	L	L1	f	h	kg		
K211	S16Q SVUCR 11	20	16	180	30	11	15	0,280	VCMT 1103	₺495
K212	S20Q SVUCR 11	25	20	180	32	13	18	0,432	ISO.	₺602
K213	S25R SVUCR 16	32	25	200	40	17	23	0,771		₺663
K214	S32T SVUCR 16	40	32	300	50	22	30	1,833	VCMT 1604	₺1.040
K215	S40T SVUCR 16	50	40	300	55	27	38	2,807	ISO.	₺1.430
Kod										
K211-K212		TC061 M2,5x6,5						T8		
K213-K215		TC074 M4x10						T15		

93° SVUCL IC Soğutmalı

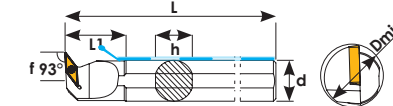
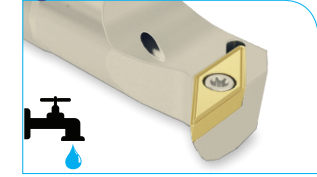

Sipariş Kodu	Ürün Kodu	Ölçüler (mm)							Uç	Fiyat
		Dmin	d	L	L1	f	h	kg		
KA300	A16Q SVUCL 11	20	16	180	30	11	15	0,268	VCMT 1103	₺573
KA302	A20Q SVUCL 11	25	20	180	32	13	18	0,689	ISO.	₺683
KA304	A25R SVUCL 16	32	25	200	40	17	23	0,720	VCMT 1604	₺767
KA306	A32T SVUCL 16	40	32	300	50	22	30	1,812	ISO.	₺1.139
Kod										
KA300-KA302		TC061 M2,5x6,5						T8		
KA304-KA306		TC074 M4x10						T15		

SVUCL

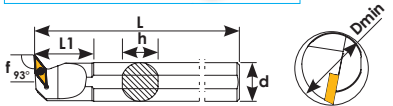
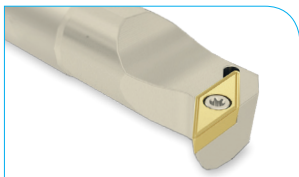

Sipariş Kodu	Ürün Kodu	Ölçüler (mm)							Uç	Fiyat
		Dmin	d	L	L1	f	h	kg		
K300	S16Q SVUCL 11	20	16	180	30	11	15	0,280	VCMT 1103	₺495
K302	S20Q SVUCL 11	25	20	180	32	13	18	0,432	ISO.	₺602
K304	S25R SVUCL 16	32	25	200	40	17	23	0,771	VCMT 1604	₺663
K306	S32T SVUCL 16	40	32	300	50	22	30	1,833	ISO.	₺1.040
Kod										
K300-K302		TC061 M2,5x6,5						T8		
K304-K306		TC074 M4x10						T15		

107,5° SVQCR IC Soğutmalı

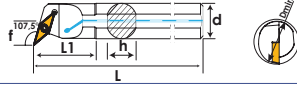

Sipariş Kodu	Ürün Kodu	Ölçüler (mm)							Uç	Fiyat
		Dmin	d	L	L1	f	h	kg		
KA221	A16Q SVQCR 11	20	16	180	30	11	15	0,271	VCMT 1103	₺573
KA222	A20Q SVQCR 11	25	20	180	30	13	18	1,752	ISO.	₺683

TC061 M2,5x7 T8

107,5° SVQCR

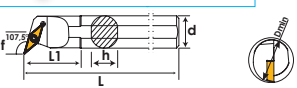
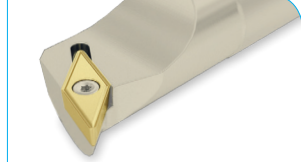

Sipariş Kodu	Ürün Kodu	Ölçüler (mm)							Uç	Fiyat
		Dmin	d	L	L1	f	h	kg		
K221	S16Q SVQCR 11	20	16	180	30	11	15	0,281	VCMT 1103	₺495
K222	S20Q SVQCR 11	25	20	180	30	13	18	1,762	ISO.	₺602
K223	S25R SVQCR 16	32	25	200	50	17	23	0,728		₺663
K224	S32T SVQCR 16	40	32	300	50	22	30	1,786	VCMT 1604	₺1.040
K225	S40T SVQCR 16	50	40	300	55	27	38		ISO.	₺1.430

Kod TC061 M2,5x6,5 T8
K221-K222 TC074 M4x10 T15
K223-K225

107,5° SVQCL IC Soğutmalı

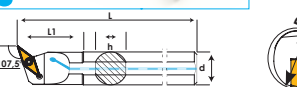
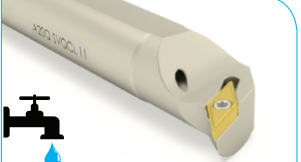

Sipariş Kodu	Ürün Kodu	Ölçüler (mm)							Uç	Fiyat
		Dmin	d	L	L1	f	h	kg		
KA319	A16Q SVQCL 11	20	16	180	30	11	15	0,271	VCMT 1103	₺573
KA320	A20Q SVQCL 11	25	20	180	30	13	18	1,752	ISO.	₺683

TC061 M2,5x7 T8

107,5° SVQCL

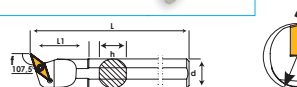

Sipariş Kodu	Ürün Kodu	Ölçüler (mm)							Uç	Fiyat
		Dmin	d	L	L1	f	h	kg		
K319	S16Q SVQCL 11	20	16	180	30	11	15	0,281	VCMT 1103	₺495
K320	S20Q SVQCL 11	25	20	180	30	13	18	1,762	ISO.	₺602
K322	S25R SVQCL 16	32	25	200	50	17	23	0,728	VCMT 1604	₺663
K324	S32T SVQCL 16	40	32	300	50	22	30	1,786	ISO.	₺1.040

Kod TC061 M2,5x6,5 T8
K319-K320 TC074 M4x10 T15
K322-K324

107,5° SVQBR

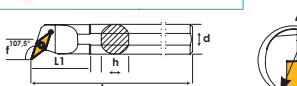
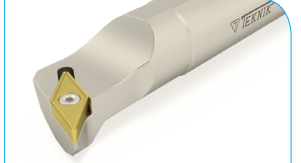

Sipariş Kodu	Ürün Kodu	Ölçüler (mm)							Uç	Fiyat
		Dmin	d	L	L1	f	h	kg		
K216	S16Q SVQBR 11	20	16	180	30	11	15	0,276	VBMT 1103	₺495
K217	S20Q SVQBR 11	25	20	180	30	13	18	0,422	ISO.	₺602
K218	S25R SVQBR 16	32	25	200	50	17	23	0,725		₺663
K219	S32T SVQBR 16	40	32	300	50	22	30	1,790	VBMT 1604	₺1.040
K220	S40T SVQBR 16	50	40	300	55	27	38	2,765	ISO.	₺1.430

Kod TC061 M2,5x6,5 T8
K216-K217 TC074 M4x10 T15
K218-K220

107,5° SVQBL

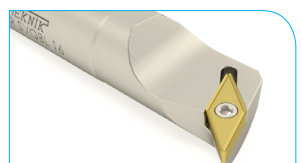

Sipariş Kodu	Ürün Kodu	Ölçüler (mm)							Uç	Fiyat
		Dmin	d	L	L1	f	h	kg		
K310	S16Q SVQBL 11	20	16	180	30	11	15	0,276	VBMT 1103	₺495
K312	S20Q SVQBL 11	25	20	180	30	13	18	0,422	ISO.	₺602
K314	S25R SVQBL 16	32	25	200	50	17	23	0,725		₺663
K316	S32T SVQBL 16	40	32	300	50	22	30	1,790	VBMT 1604	₺1.040
K318	S40T SVQBL 16	50	40	300	55	27	38	2,765	ISO.	₺1.430

Kod TC061 M2,5x6,5 T8
K310-K312 TC074 M4x10 T15
K314-K318



Kalite İçin Teknik Çözüm
Technical solution for quality



www.teknikcuttingtools.com

Uç Bağlama Sistemleri Insert Clamping Systems Wendeplatten klem systems

Karbür İç Çap Kater / Set

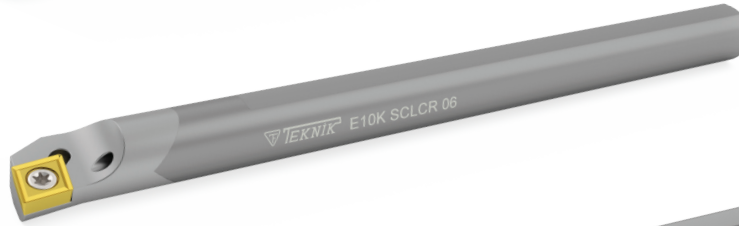

www.teknikcuttingtools.com



Kalite için TEKNİK çözüm
Technical solution for quality

118-120





E-SCLCR SET

Sipariş Kodu	Ürün Kodu in Set	Uç	Fiyat
İPS30 	E08K SCLCR 06	CCMT 0602	374 €
	E10K SCLCR 06	ISO.	
	E12M SCLCR 06		

E-SCLCL SET

Sipariş Kodu	Ürün Kodu in Set	Uç	Fiyat
İPS31 	E08K SCLCL 06	CCMT 0602	374 €
	E10K SCLCL 06	ISO.	
	E12M SCLCL 06		

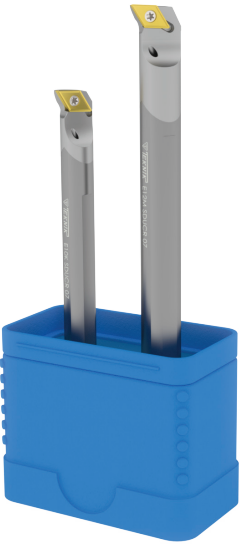

E-SDUCR SET

Sipariş Kodu	Ürün Kodu in Set	Uç	Fiyat
İPS32 	E10K SDUCR 07	DCMT 0702	258 €
	E12M SDUCR 07	ISO.	

E-SDUCL SET

Sipariş Kodu	Ürün Kodu in Set	Uç	Fiyat
İPS33 	E10K SDUCL 07	DCMT 0702	258 €
	E12M SDUCL 07	ISO.	



E-SDQCR SET

Sipariş Kodu	Ürün Kodu in Set	Uç	Fiyat
İPS34 	E10K SDQCR 07	DCMT 0702	258 €
	E12M SDQCR 07	ISO.	

E-SDQCL SET

Sipariş Kodu	Ürün Kodu in Set	Uç	Fiyat
İPS35 	E10K SDQCL 07	DCMT 0702	258 €
	E12M SDQCL 07	ISO.	

95° E-SCLCR IC

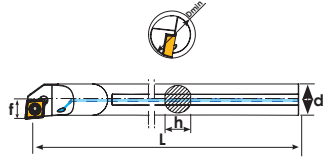
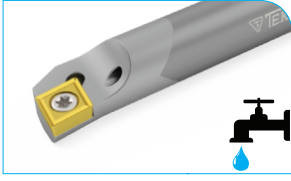

Sipariş Kodu	Ürün Kodu	Ölçüler (mm)						Uç	Fiyat
		Dmin	d	L	f	h	kg		
KE10	E08K SCLCR 06	10	8	125	5	7,5	0,050	CCMT 0602	114 €
KE11	E10K SCLCR 06	12	10	125	6	9,5	0,100	ISO.	128 €
KE12	E12M SCLCR 06	16	12	150	7	11,5	0,200		132 €
KE13	E16R SCLCR 09	20	16	200	10	15,5	0,500	CCMT 09T3	242 €
KE14	E20S SCLCR 09	25	20	250	13	19,5	0,950	ISO	410 €
Kod									
KE10-KE12		TC060 M2,5x5,5				T8			
KE13-KE14		TC067 M3,5x8,5				T15			

95° E-SCLCL IC

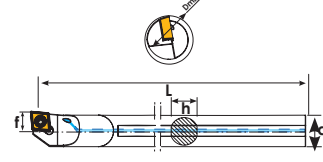

Sipariş Kodu	Ürün Kodu	Ölçüler (mm)						Uç	Fiyat
		Dmin	d	L	f	h	kg		
KE17	E08K SCLCL 06	10	8	125	5	7,5	0,050	CCMT 0602	114 €
KE18	E10K SCLCL 06	12	10	125	6	9,5	0,100	ISO.	128 €
KE19	E12M SCLCL 06	16	12	150	7	11,5	0,200		132 €
KE20	E16R SCLCL 09	20	16	200	10	15,5	0,500	CCMT 09T3	242 €
KE21	E20S SCLCL 09	25	20	250	13	19,5	0,950	ISO	410 €
Kod									
KE17-KE19		TC060 M2,5x5,5				T8			
KE20-KE21		TC067 M3,5x8,5				T15			

93° E-SDUCR IC

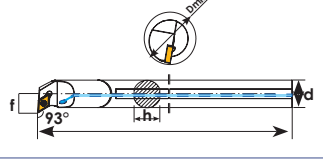

Sipariş Kodu	Ürün Kodu	Ölçüler (mm)						Uç	Fiyat
		Dmin	d	L	f	h	kg		
KE30	E10K SDUCR 07	13	10	125	7	9,5	0,050	DCMT 0702	128 €
KE31	E12M SDUCR 07	16	12	150	9	11,5	0,100	ISO.	132 €
KE32	E16R SDUCR 07	20	16	200	11	15,5	0,200		242 €
KE33	E16R SDUCR 11	20	16	200	11	15,5	0,500	DCMT 11T3	242 €
KE34	E20S SDUCR 11	25	20	250	13	19,5	0,950	ISO	410 €
Kod									
KE30-KE32		TC060 M2,5x5,5				T8			
KE33-KE34		TC067 M3,5x8,5				T15			

93° E-SDUCL IC

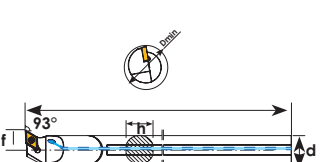

Sipariş Kodu	Ürün Kodu	Ölçüler (mm)						Uç	Fiyat
		Dmin	d	L	f	h	kg		
KE40	E10K SDUCL 07	13	10	125	7	9,5	0,050	DCMT 0702	128 €
KE41	E12M SDUCL 07	16	12	150	9	11,5	0,100	ISO.	132 €
KE42	E16R SDUCL 07	20	16	200	11	15,5	0,200		242 €
KE43	E16R SDUCL 11	20	16	200	11	15,5	0,500	DCMT 11T3	242 €
KE44	E20S SDUCL 11	25	20	250	13	19,5	0,950	ISO	410 €
Kod									
KE40-KE42		TC060 M2,5x5,5				T8			
KE43-KE44		TC067 M3,5x8,5				T15			

107,5° E-SDQCR IC

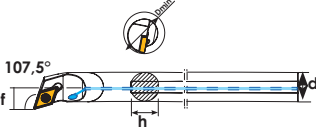

Sipariş Kodu	Ürün Kodu	Ölçüler (mm)						Uç	Fiyat
		Dmin	d	L	f	h	kg		
KE50	E10K SDQCR 07	13	10	125	7	9,5	0,050	DCMT 0702	128 €
KE51	E12M SDQCR 07	16	12	150	9	11,5	0,100	ISO.	132 €
KE52	E16R SDQCR 07	20	16	200	11	15,5	0,200		242 €
KE53	E16R SDQCR 11	20	16	200	11	15,5	0,500	DCMT 11T3	242 €
KE54	E20S SDQCR 11	25	20	250	13	19,5	0,950	ISO	410 €
Kod									
KE50-KE52		TC060 M2,5x5,5				T8			
KE53-KE54		TC067 M3,5x8,5				T15			

107,5° E-SDQCL IC

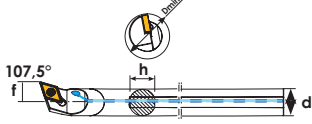
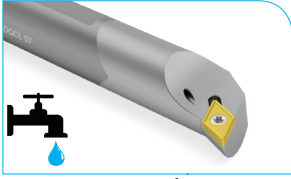

Sipariş Kodu	Ürün Kodu	Ölçüler (mm)						Uç	Fiyat
		Dmin	d	L	f	h	kg		
KE60	E10K SDQCL 07	13	10	125	7	9,5	0,050	DCMT 0702	128 €
KE61	E12M SDQCL 07	16	12	150	9	11,5	0,100	ISO.	132 €
KE62	E16R SDQCL 07	20	16	200	11	15,5	0,200		242 €
KE63	E16R SDQCL 11	20	16	200	11	15,5	0,500	DCMT 11T3	242 €
KE64	E20S SDQCL 11	25	20	250	13	19,5	0,950	ISO	410 €
Kod									
KE60-KE62		TC060 M2,5x5,5				T8			
KE63-KE64		TC067 M3,5x8,5				T15			

Karbür İç Çap Diş Katerleri/R Soğutmalı

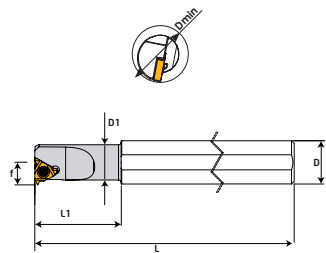
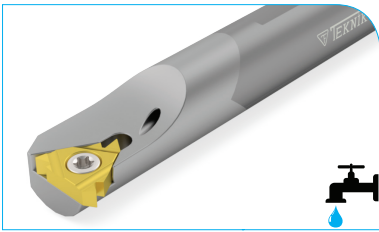

Sipariş Kodu	Ürün Kodu	Ölçüler (mm)					Uç	Fiyat	
		D	L	L1	f	Dmin			
KE70	E06H - IR06	6	100	26	4,3	6	0,024	6 IR	114 €
KE71	E08K - IR08	8	125	31	5,3	7,8	0,045	8 IR	114 €
KE72	E10M - IR11	10	150	-	7,4	12	0,085	11 IR	135 €
KE73	E12P - IR11	12	170	-	8,4	15	0,150	11 IR	160 €
KE74	E16R - IR16	16	200	-	11,7	19	0,260	16 IR	242 €
KE75	E20S - IR16	20	250	-	13,7	24	0,560	16 IR	410 €
KE76	E25S - IR16	25	250	-	16,2	29	0,900	16 IR	520 €
KE78	E20S - IR22	20	250	-	15,6	24,5	0,570	22 IR	410 €
Kod									
KE70		TC058-1M2x4,2		--		--		T6	
KE71		TC058 M2x4,6		--		--		T8	
KE72-KE72		TC060 M2,5x5,5		--		--		T8	
KE74		TC067 M3,5x8,5		--		--		T15	
KE75-KE76		TC068 M3,5x11		TA060		BSP010		TC062 M3	
KE78		TC078 M4x11		--		--		T15	

Karbür Threa Cutting Tool Soğutmalı

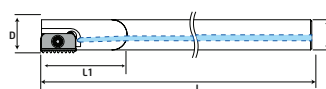

Sipariş Kodu	Ürün Kodu	Ölçüler (mm)					Uç	Fiyat	
		A	D	d	L	L1			
KE90	D9,9 d08 L125 A12 S12	12	9,9	8	125	-	0,049	S12	114 €
KE91	D13,2 d10 L110 A14 S14	14	13,2	10	110	-	0,067	S14	128 €
KE92	D13,2 d10 L155 A14 S14	14	13,2	10	155	-	0,100	S14	137 €
KE93	D15,2 d12 L175 A14 S14	14	15,2	12	175	-	0,167	S14	154 €
KE94	D21 d16 L130 A21 S21	21	21	16	130	-	0,212	S21	209 €
KE95	D21 d16 L200 A21 S21	21	21	16	200	-	0,327	S21	258 €
Kod									
KE90		TC092 M2,5x5,5		--		--		T8	
KE91-KE93		TC093 M2,5x7		--		--		T15	
KE94-KE95		TC074 M4x10		--		--		T15	

İç Çap Kater Set



www.teknikcuttingtools.com



Kalite için TEKNİK çözüm
Technical solution for quality

122-123



SCLCR SET

Sipariş Kodu	Ürün Kodu in Set	Uç	Fiyat
İPS01 	A08H SCLCR 06	CCMT 0602	₺1.573
	A10J SCLCR 06	ISO.	
	A12K SCLCR 06		
	A16M SCLCR 09	CCMT 09T3	

SCLCL SET

Sipariş Kodu	Ürün Kodu in Set	Uç	Fiyat
İPS04 	A08H SCLCL 06	CCMT 0602	₺1.573
	A10J SCLCL 06	ISO.	
	A12K SCLCL 06		
	A16M SCLCL 09	CCMT 09T3	

SDUCR SET

Sipariş Kodu	Ürün Kodu in Set	Uç	Fiyat
İPS02 	A10J SDUCR 07	DCMT 0702	₺1.223
	A12K SDUCR 07	ISO.	
	A16M SDUCR 07		

SDUCL SET

Sipariş Kodu	Ürün Kodu in Set	Uç	Fiyat
İPS05 	A10J SDUCL 07	DCMT 0702	₺1.223
	A12K SDUCL 07	ISO.	
	A16M SDUCL 07		

SDQCR SET

Sipariş Kodu	Ürün Kodu in Set	Uç	Fiyat
İPS03 	A10J SDQCR 07	DCMT 0702	₺1.223
	A12K SDQCR 07	ISO.	
	A16M SDQCR 07		

SDQCL SET

Sipariş Kodu	Ürün Kodu in Set	Uç	Fiyat
İPS06 	A10J SDQCL 07	DCMT 0702	₺1.223
	A12K SDQCL 07	ISO.	
	A16M SDQCL 07		





SCLCR SET

Sipariş Kodu	Ürün Kodu in Set	Uç	Fiyat
İPS20	S08H SCLCR 06	CCMT 0602	₺1.388
	S10J SCLCR 06	ISO.	
	S12K SCLCR 06		
	S16M SCLCR 09	CCMT 09T3	

SCLCL SET

Sipariş Kodu	Ürün Kodu in Set	Uç	Fiyat
İPS21	S08H SCLCL 06	CCMT 0602	₺1.388
	S10J SCLCL 06	ISO.	
	S12K SCLCL 06		
	S16M SCLCL 09	CCMT 09T3	



SDUCR SET

Sipariş Kodu	Ürün Kodu in Set	Uç	Fiyat
İPS22	S10J SDUCR 07	DCMT 0702	₺1.058
	S12K SDUCR 07	ISO.	
	S16M SDUCR 11	DCMT 11T3	

SDUCL SET

Sipariş Kodu	Ürün Kodu in Set	Uç	Fiyat
İPS23	S10J SDUCL 07	DCMT 0702	₺1.058
	S12K SDUCL 07	ISO.	
	S16M SDUCL 11	DCMT 11T3	

SDQCR SET

Sipariş Kodu	Ürün Kodu in Set	Uç	Fiyat
İPS24	S10J SDQCR 07	DCMT 0702	₺1.058
	S12K SDQCR 07	ISO.	
	S16M SDQCR 11	DCMT 11T3	

SDQCL SET

Sipariş Kodu	Ürün Kodu in Set	Uç	Fiyat
İPS25	S10J SDQCL 07	DCMT 0702	₺1.058
	S12K SDQCL 07	ISO.	
	S16M SDQCL 11	DCMT 11T3	

Kalite için TEKNİK çözüm
Technical solution for quality



Udiril



www.teknikcuttingtools.com



Kalite için TEKNİK çözüm
Technical solution for quality

126-135



U-DRIL Eksantrik Adaptör

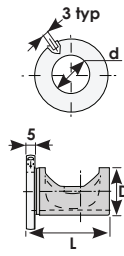

Sipariş Kodu	Ürün Kodu	Ölçüler (mm)			Fiyat
		D	d	L	
UA10	D25 d20 L46	25	20	46,5	₺833
UA12	D32 d25 L47	32	25	47	₺833
UA14	D40 d32 L57	40	32	57	₺833

D2 WCM_

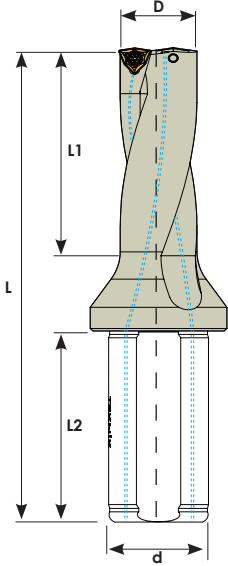
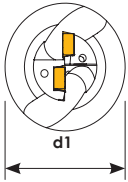
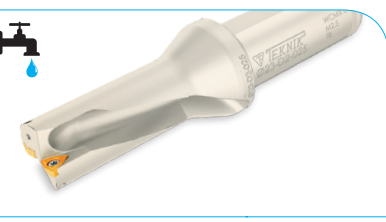

Sipariş Kodu	Ürün Kodu	Ölçüler (mm)							Uç	Fiyat
		D	d	d1	L	L1	L2			
U104	16 D2 WCM_03	16	25	34	108	32	56	0,294	WCM_0302	₺1.489
U105	17 D2 WCM_03	17	25	34	110	34	56	0,293	KRLY	₺1.489
U106	18 D2 WCM_03	18	25	34	113	36	56	0,303		₺1.489
U107	19 D2 WCM_03	19	25	34	115	38	56	0,312		₺1.489
U108	20 D2 WCM_04	20	25	34	119	40	56	0,327		₺1.607
U110	21 D2 WCM_04	21	25	34	121	42	56	0,340	WCM_0402	₺1.607
U112	22 D2 WCM_04	22	25	34	123	44	56	0,345	KRLY	₺1.607
U114	23 D2 WCM_04	23	25	34	127	46	56	0,370		₺1.607
U116	24 D2 WCM_05	24	25	34	130	48	56	0,390		₺1.687
U118	25 D2 WCM_05	25	25	34	133	50	56	0,420		₺1.687
U120	26 D2 WCM_05	26	25	34	135	52	56	0,420	WCM_0503	₺1.687
U122	27 D2 WCM_05	27	25	34	137	54	56	0,450	KRLY	₺1.687
U124	28 D2 WCM_05	28	25	39	140	56	56	0,491		₺1.687
U126	29 D2 WCM_05	29	25	39	142	58	56	0,515		₺1.687
U128	30 D2 WCM_06	30	32	44	151	60	58	0,755		₺1.785
U130	31 D2 WCM_06	31	32	44	154	62	58	0,775		₺1.785
U132	32 D2 WCM_06	32	32	44	156	64	58	0,802		₺1.785
U134	33 D2 WCM_06	33	32	44	159	66	58	0,845	WCM_06T3	₺1.785
U136	34 D2 WCM_06	34	32	44	161	68	58	0,851	KRLY	₺1.785
U137	35 D2 WCM_06	35	32	44	164	70	58	0,900		₺1.866
U138	36 D2 WCM_06	36	32	44	167	72	58	0,970		₺1.866
U139	37 D2 WCM_06	37	32	44	170	74	58	0,875		₺1.866
U140	38 D2 WCM_06	38	32	44	173	76	58	0,975		₺1.866
U141	39 D2 WCM_06	39	32	44	175	78	58	1,006		₺1.866
U142	40 D2 WCM_06	40	32	44	178	80	58	1,007		₺1.866

Kod

U104-U114	TC060 M2,5x5,5	T8
U116-U126	TC065 M3x7	T8
U128-U142	TC067 M3,5x8,5	T10



KRLY Ucuna Uygundur.

D3 WCM_

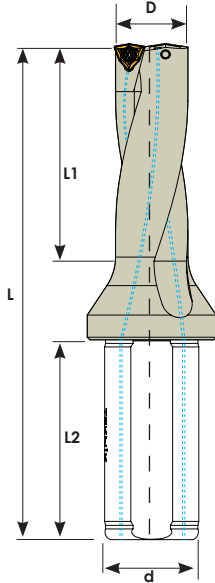
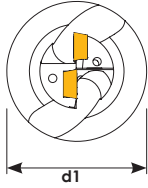

Sipariş Kodu	Ürün Kodu	Ölçüler (mm)								Uç	Fiyat
		D	d	d1	L	L1	L2	kg			
U143	16 D3 WCM_03	16	25	34	124	48	56	0,307		₺1.648	
U143-1	16,5 D3 WCM_03	16,5	25	34	124	48	56	0,304		₺1.648	
U144	17 D3 WCM_03	17	25	34	127	51	56	0,320	WCM_0302	₺1.648	
U145	17,5 D3 WCM_03	17,5	25	34	127	51	56	0,336	KRLY	₺1.648	
U146	18 D3 WCM_03	18	25	34	131	54	56	0,332		₺1.648	
U147	18,5 D3 WCM_03	18,5	25	34	131	54	56	0,348		₺1.648	
U148	19 D3 WCM_03	19	25	34	134	57	56	0,338		₺1.648	
U149	19,5 D3 WCM_03	19,5	25	34	134	57	56	0,340		₺1.648	
U150	20 D3 WCM_04	20	25	34	139	60	56	0,344		₺1.707	
U151	20,5 D3 WCM_04	20,5	25	34	139	60	56	0,360		₺1.707	
U152	21 D3 WCM_04	21	25	34	142	63	56	0,376	WCM_0402	₺1.707	
U153	21,5 D3 WCM_04	21,5	25	34	142	63	56	0,281	KRLY	₺1.707	
U154	22 D3 WCM_04	22	25	34	145	66	56	0,385		₺1.707	
U155	22,5 D3 WCM_04	22,5	25	34	145	66	56	0,394		₺1.707	
U156	23 D3 WCM_04	23	25	34	150	69	56	0,400		₺1.707	
U157	23,5 D3 WCM_04	23,5	25	34	150	69	56	0,413		₺1.707	
U158	24 D3 WCM_05	24	25	34	154	72	56	0,446		₺1.785	
U159	24,5 D3 WCM_05	24,5	25	34	154	72	56	0,453		₺1.785	
U160	25 D3 WCM_05	25	25	34	158	75	56	0,467	WCM_0503	₺1.785	
U161	25,5 D3 WCM_05	25,5	25	34	158	75	56	0,490	KRLY	₺1.785	
U162	26 D3 WCM_05	26	25	34	161	78	56	0,494		₺1.785	
U163	26,5 D3 WCM_05	26,5	25	34	161	78	56	0,497		₺1.785	
U164	27 D3 WCM_05	27	25	34	164	81	56	0,512		₺1.785	
U165	27,5 D3 WCM_05	27,5	25	34	164	81	56	0,520		₺1.785	
U166	28 D3 WCM_05	28	25	39	168	84	56	0,576		₺1.785	
U167	28,5 D3 WCM_05	28,5	25	39	168	84	56	0,584		₺1.785	
U168	29 D3 WCM_05	29	25	39	171	87	56	0,617		₺1.785	
U169	29,5 D3 WCM_05	29,5	25	39	171	87	56	0,610		₺1.785	
Kod											
U143-U157		TC060 M2,5x5,5									
U158-U169		TC065 M3x7 M3,5x9				T8					

KRLY Ucuna Uygunur.

D3 WCM_

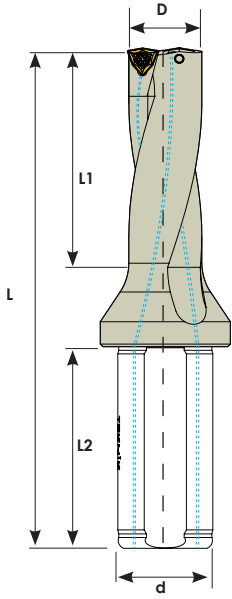
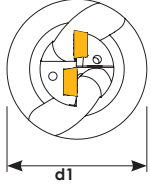

Sipariş Kodu	Ürün Kodu	Ölçüler (mm)								Uç	Fiyat
		D	d	d1	L	L1	L2				
U170	30 D3 WCM_06	30	32	44	181	90	58	0,847		₺1.825	
U171	30,5 D3 W_M_06	30,5	32	44	181	90	58	0,844		₺1.825	
U172	31 D3 WCM_06	31	32	44	185	93	58	0,872	WCM_06T3	₺1.825	
U174	32 D3 WCM_06	32	32	44	188	96	58	0,921	KRLY	₺1.825	
U176	33 D3 WCM_06	33	32	44	192	99	58	0,973		₺1.825	
U178	34 D3 WCM_06	34	32	44	195	102	58	1,037		₺1.825	
U179	35 D3 WCM_06	35	32	44	199	105	58	1,082		₺1.886	
U180	36 D3 WCM_06	36	32	44	203	108	58	1,092		₺1.886	
U181	37 D3 WCM_06	37	32	44	207	111	58	1,141		₺1.886	
U182	38 D3 WCM_06	38	32	44	211	114	58	1,188		₺1.886	
U183	39 D3 WCM_06	39	32	44	214	117	58	1,244		₺1.886	
U184	40 D3 WCM_06	40	32	44	218	120	58	1,295		₺2.064	
U186	41 D3 WCM_06	41	32	49	232	123	58	1,465		₺2.064	
U188	42 D3 WCM_06	42	32	49	235	126	58	1,646		₺2.064	
U190	43 D3 WCM_06	43	32	54	239	129	58	1,726		₺2.064	
U192	44 D3 WCM_06	44	32	54	242	132	58	1,916		₺2.064	
U194	45 D3 WCM_06	45	40	59	247	135	68	2,238		₺2.064	
U196	46 D3 WCM_08	46	40	59	251	138	68	2,276		₺2.142	
U198	47 D3 WCM_08	47	40	59	254	141	68	1,919		₺2.142	
U200	48 D3 WCM_08	48	40	59	258	144	68	2,486		₺2.142	
U201	49 D3 WCM_08	49	40	59	261	147	68	5,562		₺2.579	
U202	50 D3 WCM_08	50	40	59	265	150	68	2,725	WCM_0804	₺2.579	
U203	51 D3 WCM_08	51	40	59	268	153	68	2,537	KRLY	₺2.874	
U205	52 D3 WCM_08	52	40	59	271	156	68	2,655		₺2.874	
U207	53 D3 WCM_08	53	40	59	274	159	68	2,740		₺3.134	
U209	54 D3 WCM_08	54	40	59	277	162	68	3,210		₺3.134	
U211	55 D3 WCM_08	55	40	59	280	165	68	3,237		₺3.215	

Kod

U170-U194
U196-U211

TC067 M3,5x8,5
TC074 M4x10

T15



KRLY Ucuna Uygundur.

D4 WCM_

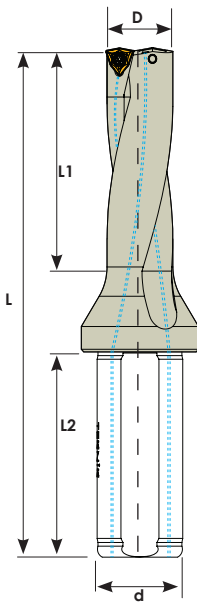
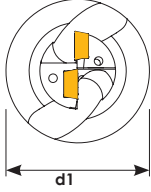

Sipariş Kodu	Ürün Kodu	Ölçüler (mm)							Uç	Fiyat
		D	d	d1	L	L1	L2	kg		
U600	16 D4 WCM_03	16	25	34	140	64	56	0,324		₺2.124
U602	17 D4 WCM_03	17	25	34	144	68	56	0,328	WCM_0302	₺2.124
U604	18 D4 WCM_03	18	25	34	149	72	56	0,355	KRLY	₺2.124
U606	19 D4 WCM_03	19	25	34	153	76	56	0,357		₺2.124
U608	20 D4 WCM_04	20	25	34	159	80	56	0,383	WCM_0402	₺2.220
U610	21 D4 WCM_04	21	25	34	163	84	56	0,411	KRLY	₺2.220
U612	22 D4 WCM_04	22	25	34	167	88	56	0,430		₺2.220
U614	23 D4 WCM_04	23	25	34	173	92	56	0,464		₺2.220
U616	24 D4 WCM_05	24	25	34	178	96	56	0,425		₺2.321
U618	25 D4 WCM_05	25	25	34	183	100	56	0,526		₺2.321
U620	26 D4 WCM_05	26	25	34	187	104	56	0,542	WCM_0503	₺2.321
U622	27 D4 WCM_05	27	25	34	191	108	56	0,580	KRLY	₺2.321
U624	28 D4 WCM_05	28	25	39	196	112	56	0,662		₺2.321
U626	29 D4 WCM_05	29	25	39	200	116	56	0,680		₺2.321
U628	30 D4 WCM_06	30	32	44	211	120	58	0,912		₺2.400
U631	31 D4 WCM_06	31	32	44	216	124	58	0,981		₺2.400
U632	32 D4 WCM_06	32	32	44	220	128	58	1,046		₺2.400
U633	33 D4 WCM_06	33	32	44	225	132	58	1,102		₺2.400
U634	34 D4 WCM_06	34	32	44	229	136	58	1,111	WCM_06T3	₺2.457
U635	35 D4 WCM_06	35	32	44	234	140	58	1,187	KRLY	₺2.457
U636	36 D4 WCM_06	36	32	44	239	144	58	1,172		₺2.457
U637	37 D4 WCM_06	37	32	44	244	148	58	1,260		₺2.457
U638	38 D4 WCM_06	38	32	44	249	152	58	1,430		₺2.579
U639	39 D4 WCM_06	39	32	44	253	156	58	1,380		₺2.579
U640	40 D4 WCM_06	40	32	44	258	160	58	1,460		₺2.579

Kod

U600-U614

TC060 M2,5x5,5

T8

U616-U626

TC065 M3x7

T15

U628-640

TC067 M3,5x8,5

T15



KRLY Ucuna Uygundur.

D5 WCM_

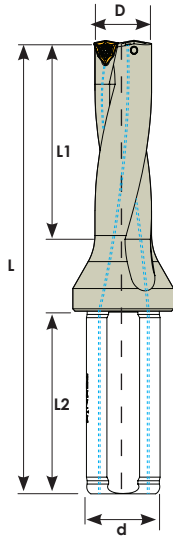
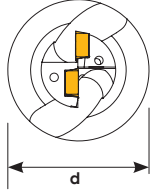

Sipariş Kodu	Ürün Kodu	Ölçüler (mm)							Uç	Fiyat
		D	d	d1	L	L1	L2			
U776	16 D5 WCM_03	16	25	34	156	80	56	0,378		₺2.501
U777	17 D5 WCM_03	17	25	34	161	85	56	0,468	WCM_0302	₺2.501
U778	18 D5 WCM_03	18	25	34	167	90	56	0,471	KRLY	₺2.501
U779	19 D5 WCM_03	19	25	34	172	95	56	0,397		₺2.501
U780	20 D5 WCM_04	20	25	34	179	100	56	0,421		₺2.501
U781	21 D5 WCM_04	21	25	34	184	105	56	0,451	WCM_0402	₺2.501
U782	22 D5 WCM_04	22	25	34	190	110	56	0,470	KRLY	₺2.501
U783	23 D5 WCM_04	23	25	34	196	115	56	0,504		₺2.501
U784	24 D5 WCM_05	24	25	34	202	120	56	0,465		₺2.698
U785	25 D5 WCM_05	25	25	34	208	125	56	0,678	WCM_0503	₺2.698
U786	26 D5 WCM_05	26	25	34	213	130	56	0,620	KRLY	₺2.698
U787	27 D5 WCM_05	27	25	34	218	135	56	0,620		₺2.698
U788	28 D5 WCM_05	28	25	39	224	140	56	0,742		₺2.698
U789	29 D5 WCM_05	29	25	39	229	145	56	0,760		₺2.698
U790	30 D5 WCM_06	30	32	44	241	150	58	0,992		₺2.816
U791	31 D5 WCM_06	31	32	44	246	155	58	1,061		₺2.816
U792	32 D5 WCM_06	32	32	44	252	160	58	1,126	WCM_06T3	₺2.816
U793	33 D5 WCM_06	33	32	44	258	165	58	1,182	KRLY	₺2.816
U794	34 D5 WCM_06	34	32	44	263	170	58	1,191		₺2.935
U795	35 D5 WCM_06	35	32	44	269	175	58	1,227		₺2.935
U796	36 D5 WCM_06	36	32	44	275	180	58	1,172		₺2.935
U797	37 D5 WCM_06	37	32	44	281	185	58	1,300		₺2.935
U798	38 D5 WCM_06	38	32	44	287	190	58	1,480		₺3.251
U799	39 D5 WCM_06	39	32	44	292	195	58	1,520		₺3.251
U800	40 D5 WCM_06	40	32	44	298	200	58	1,490		₺3.251

Kod

U776-U783

TC060 M2,5x5,5

U784-U789

TC065 M3x7 M3,5x9

U790-U800

TC067 M3,5x8,5



T8



T15

KRLY Ucuna Uygundur.

D2 SPMG

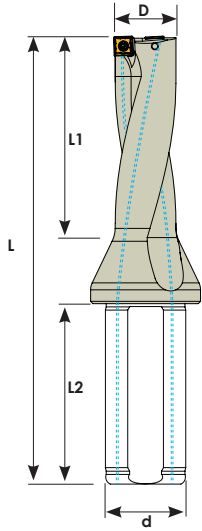
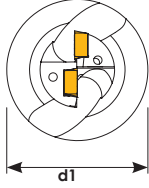



Sipariş Kodu	Ürün Kodu	Ölçüler (mm)							Uç	Fiyat
		D	d	d1	L	L1	L2	kg		
U913	13 D2 SPMG 05	13	20	25	94	26	50	0,145	SPMG 0502	₺1.489
U914	14 D2 SPMG 05	14	20	25	96	28	50	0,152	TGTC YG-1	₺1.489
U915	15 D2 SPMG 05	15	20	25	99	30	50	0,157		₺1.489
U916	16 D2 SPMG 06	16	25	34	108	32	56	0,275		₺1.489
U917	17 D2 SPMG 06	17	25	34	110	34	56	0,291		₺1.489
U918	18 D2 SPMG 06	18	25	34	113	36	56	0,302	SPMG 0602	₺1.489
U919	19 D2 SPMG 06	19	25	34	115	38	56	0,329	TGTC YG-1	₺1.489
U920	20 D2 SPMG 06	20	25	34	119	40	56	0,334		₺1.607
U921	21 D2 SPMG 06	21	25	34	121	42	56	0,338		₺1.607
U922	22 D2 SPMG 07	22	25	34	123	44	56	0,340		₺1.607
U923	23 D2 SPMG 07	23	25	34	127	46	56	0,354	SPMG 07T3	₺1.607
U924	24 D2 SPMG 07	24	25	34	130	48	56	0,382	TGTC YG-1	₺1.687
U925	25 D2 SPMG 07	25	25	34	133	50	56	0,450		₺1.687
U926	26 D2 SPMG 07	26	25	34	135	52	56	0,423		₺1.687
U927	27 D2 SPMG 07	27	25	34	137	54	56	0,435		₺1.687
U928	28 D2 SPMG 09	28	25	39	140	56	56	0,500		₺1.687
U929	29 D2 SPMG 09	29	25	39	142	58	56	0,535	SPMG 0904	₺1.687
U930	30 D2 SPMG 09	30	32	44	151	60	58	0,735	TGTC YG-1	₺1.785
U931	31 D2 SPMG 09	31	32	44	154	62	58	0,766		₺1.785
U932	32 D2 SPMG 09	32	32	44	156	64	58	0,781		₺1.785
U933	33 D2 SPMG 09	33	32	44	159	66	58	0,815		₺1.785
U934	34 D2 SPMG 11	34	32	44	161	68	58	0,784		₺1.785
U935	35 D2 SPMG 11	35	32	44	164	70	58	0,845	SPMG 1104	₺1.866
U936	36 D2 SPMG 11	36	32	44	167	72	58	0,893	TGTC YG-1	₺1.866
U937	37 D2 SPMG 11	37	32	44	170	74	58	0,931		₺1.866
U938	38 D2 SPMG 11	38	32	44	173	76	58	0,992		₺1.866
U939	39 D2 SPMG 11	39	32	44	175	78	58	1,007		₺1.866
U940	40 D2 SPMG 11	40	32	44	178	80	58	1,020		₺1.866

Kod		
U913-U915	TC058 M2x4,2	T6
U916-U921	TC059 M2,2x5	T7
U922-U927	TC063 M2,5x7	T8
U928-U933	TC067 M3,5x8,5	T15
U934-U940	TC074 M4x10	

TGTC-YG-1 Ucuna Uygunudur.

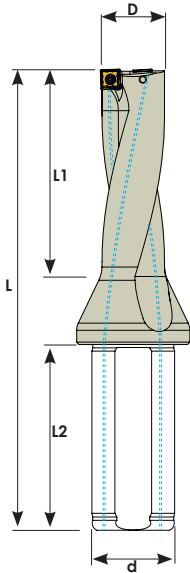
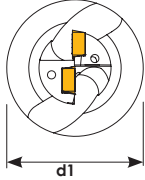
D3 SPMG



Sipariş Kodu	Ürün Kodu	Ölçüler (mm)								Uç	Fiyat
		D	d	d1	L	L1	L2				
U812	12,5 D3 SPMG 05	12,5	20	12	106	38	50	0,158		₺1.648	
U813	13 D3 SPMG 05	13	20	25	107	39	50	0,164	SPMG 0502	₺1.648	
U813-1	13,5 D3 SPMG 05	13,5	20	25	107	39	50	0,167	TGTC	₺1.648	
U814	14 D3 SPMG 05	14	20	25	110	42	50	0,170	YG-1	₺1.648	
U814-1	14,5 D3 SPMG 05	14,5	20	25	110	42	50	0,170		₺1.648	
U815	15 D3 SPMG 05	15	20	25	114	45	50	0,175		₺1.648	
U815-1	15,5 D3 SPMG 05	15,5	20	25	114	45	50	0,175		₺1.648	
U816	16 D3 SPMG 06	16	25	34	124	48	56	0,302		₺1.648	
U816-1	16,5 D3 SPMG 06	16,5	25	34	124	48	56	0,302		₺1.648	
U817	17 D3 SPMG 06	17	25	34	127	51	56	0,318		₺1.648	
U817-1	17,5 D3 SPMG 06	17,5	25	34	127	51	56	0,318		₺1.648	
U818	18 D3 SPMG 06	18	25	34	131	54	56	0,327	SPMG 0602	₺1.648	
U818-1	18,5 D3 SPMG 06	18,5	25	34	131	54	56	0,327	TGTC	₺1.648	
U819	19 D3 SPMG 06	19	25	34	134	57	56	0,330	YG-1	₺1.648	
U819-1	19,5 D3 SPMG 06	19,5	25	34	134	57	56	0,330		₺1.648	
U820	20 D3 SPMG 06	20	25	34	139	60	56	0,347		₺1.707	
U820-1	20,5 D3 SPMG 06	20,5	25	34	139	60	56	0,350		₺1.707	
U821	21 D3 SPMG 06	21	25	34	142	63	56	0,377		₺1.707	
U821-1	21,5 D3 SPMG 06	21,5	25	34	142	63	56	0,377		₺1.707	
U822	22 D3 SPMG 07	22	25	34	145	66	56	0,375		₺1.707	
U822-1	22,5 D3 SPMG 07	22,5	25	34	145	66	56	0,375		₺1.707	
U823	23 D3 SPMG 07	23	25	34	150	69	56	0,407		₺1.707	
U823-1	23,5 D3 SPMG 07	23,5	25	34	150	69	56	0,412		₺1.707	
U824	24 D3 SPMG 07	24	25	34	154	72	56	0,446	SPMG 07T3	₺1.785	
U824-1	24,5 D3 SPMG 07	24,5	25	34	154	72	56	0,452	TGTC	₺1.785	
U825	25 D3 SPMG 07	25	25	34	158	75	56	0,460	YG-1	₺1.785	
U825-1	25,5 D3 SPMG 07	25,5	25	34	158	75	56	0,467		₺1.785	
U826	26 D3 SPMG 07	26	25	34	161	78	56	0,481		₺1.785	
U826-1	26,5 D3 SPMG 07	26,5	25	34	161	78	56	0,487		₺1.785	
U827	27 D3 SPMG 07	27	25	34	164	81	56	0,504		₺1.785	
U827-1	27,5 D3 SPMG 07	27,5	25	34	164	81	56	0,511		₺1.785	
U828	28 D3 SPMG 09	28	25	39	168	84	56	0,562		₺1.785	
U828-1	28,5 D3 SPMG 09	28,5	25	39	168	84	56	0,572		₺1.785	
U829	29 D3 SPMG 09	29	25	39	171	87	56	0,580	SPMG 0904	₺1.785	
U829-1	29,5 D3 SPMG 09	29,5	25	39	171	87	56	0,585	TGTC	₺1.785	
U830	30 D3 SPMG 09	30	32	44	181	90	58	0,823	YG-1	₺1.825	
U831	31 D3 SPMG 09	31	32	44	185	93	58	0,884		₺1.825	
U832	32 D3 SPMG 09	32	32	44	188	96	58	0,923		₺1.825	
U833	33 D3 SPMG 09	33	32	44	192	99	58	0,920		₺1.825	
U834	34 D3 SPMG 11	34	32	44	195	102	58	0,943		₺1.825	
U835	35 D3 SPMG 11	35	32	44	199	105	58	0,960	SPMG 1104	₺1.886	
U836	36 D3 SPMG 11	36	32	44	203	108	58	1,043	TGTC	₺1.886	
U837	37 D3 SPMG 11	37	32	44	207	111	58	1,057	YG-1	₺1.886	
U838	38 D3 SPMG 11	38	32	44	211	114	58	1,062		₺1.886	
U839	39 D3 SPMG 11	39	32	44	214	117	58	1,155		₺1.886	
U840	40 D3 SPMG 11	40	32	44	218	120	58	1,238		₺2.064	

Kod

U812-U815-1
U816-U821-1
U822-U827-1
U828-U833
U834-U840

TC058 M2x4,2
TC059 M2,2x5
TC063 M2,5x7
TC067 M3,5x8,5
TC074 M4x10

T6
T7
T8
T15



D4 SPMG

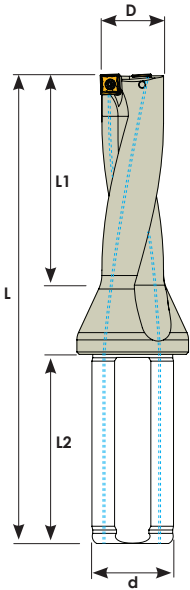
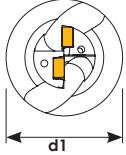

Sipariş Kodu	Ürün Kodu	Ölçüler (mm)							Uç	Fiyat
		D	d	d1	L	L1	L2			
U713	13 D4 SPMG 05	13	20	25	120	52	50	0,170	SPMG 0502	₺2.084
U714	14 D4 SPMG 05	14	20	25	124	56	50	0,180	TGTC	₺2.084
U715	15 D4 SPMG 05	15	20	25	129	60	50	0,190	YG-1	₺2.084
U716	16 D4 SPMG 06	16	25	34	140	64	56	0,330		₺2.124
U717	17 D4 SPMG 06	17	25	34	144	68	56	0,333		₺2.124
U718	18 D4 SPMG 06	18	25	34	149	72	56	0,350	SPMG 0602	₺2.124
U719	19 D4 SPMG 06	19	25	34	153	76	56	0,357	TGTC	₺2.124
U720	20 D4 SPMG 06	20	25	34	159	80	56	0,383	YG-1	₺2.220
U721	21 D4 SPMG 06	21	25	34	163	84	56	0,387		₺2.220
U722	22 D4 SPMG 07	22	25	34	167	88	56	0,417		₺2.220
U723	23 D4 SPMG 07	23	25	34	173	92	56	0,448	SPMG 07T3	₺2.321
U724	24 D4 SPMG 07	24	25	34	178	96	56	0,460	TGTC	₺2.321
U725	25 D4 SPMG 07	25	25	34	183	100	56	0,505	YG-1	₺2.321
U726	26 D4 SPMG 07	26	25	34	187	104	56	0,539		₺2.321
U727	27 D4 SPMG 07	27	25	34	191	108	56	0,561		₺2.321
U728	28 D4 SPMG 09	28	25	39	196	112	56	0,642		₺2.321
U729	29 D4 SPMG 09	29	25	39	200	116	56	0,646	SPMG 0904	₺2.321
U730	30 D4 SPMG 09	30	32	44	211	120	58	0,930	TGTC	₺2.400
U731	31 D4 SPMG 09	31	32	44	216	124	58	0,974	YG-1	₺2.400
U732	32 D4 SPMG 09	32	32	44	220	128	58	1,014		₺2.400
U733	33 D4 SPMG 09	33	32	44	225	132	58	1,050		₺2.400
U734	34 D4 SPMG 11	34	32	44	229	136	58	1,040		₺2.457
U735	35 D4 SPMG 11	35	32	44	234	140	58	1,155	SPMG 1104	₺2.457
U736	36 D4 SPMG 11	36	32	44	239	144	58	1,185	TGTC	₺2.457
U737	37 D4 SPMG 11	37	32	44	244	148	58	1,232	YG-1	₺2.457
U738	38 D4 SPMG 11	38	32	44	249	152	58	1,320		₺2.579
U739	39 D4 SPMG 11	39	32	44	253	156	58	1,356		₺2.579
U740	40 D4 SPMG 11	40	32	44	258	160	58	1,421		₺2.579

Kod			
U713-U715	TC058 M2x4,2	T6	
U716-U721	TC059 M2,2x5	T7	
U722-U727	TC063 M2,5x7	T8	
U728-U733	TC067 M3,5x8,5	T15	
U734-U740	TC074 M4x10		

TGTC insert. / Kompatibel für TGTC WP

D3 SPMT

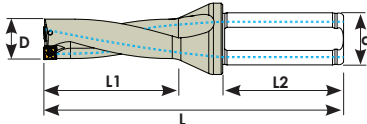
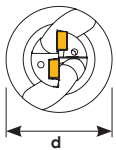
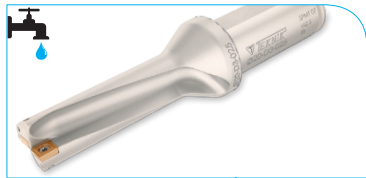

Sipariş Kodu	Ürün Kodu	Ölçüler (mm)							Uç	Fiyat
		D	d	d1	L	L1	L2			
U004	13 D3 SPMT 05	13	20	25	107	39	50	0,154	SPMT 0502	₺1.648
U006	14 D3 SPMT 05	14	20	25	110	42	50	0,158	KRLY.	₺1.648
U008	15 D3 SPMT 05	15	20	25	114	45	50	0,168		₺1.648
U010	16 D3 SPMT 06	16	25	34	124	48	56	0,308		₺1.648
U012	17 D3 SPMT 06	17	25	34	127	51	56	0,313	SPMT 0602	₺1.648
U014	18 D3 SPMT 06	18	25	34	131	54	56	0,327	KRLY.	₺1.648
U016	19 D3 SPMT 06	19	25	34	134	57	56	0,350		₺1.648
U018	20 D3 SPMT 07	20	25	34	139	60	56	0,353	SPMT 0702	₺1.707
U020	21 D3 SPMT 07	21	25	34	142	63	56	0,395	KRLY.	₺1.707

Kod			
U004-U008	TC058 M2x4,2	T6	
U010-U016	TC059 M2,2x5	T7	
U018-U022	TC063 M2,5x7	T8	

KRLY Ucuna Uygundur.

D3 SOMT

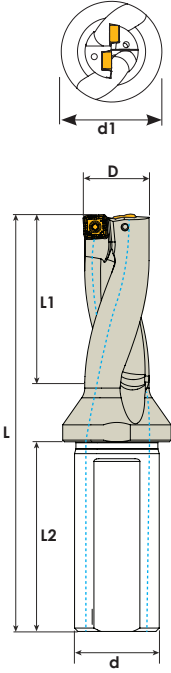

Sipariş Kodu	Ürün Kodu	Ölçüler (mm)							Uç	Fiyat
		D	d	d1	L	L1	L2	kg		
U300	13 D3 SOMT 05	13	20	25	111	39	50	0,157		₺1.648
U302	14 D3 SOMT 05	14	20	25	114	42	50	0,165	SOMT 0502	₺1.648
U303	14,5 D3 SOMT 05	14,5	20	25	114	42	50	0,170	TGTC	₺1.648
U304	15 D3 SOMT 05	15	20	25	117	45	50	0,175		₺1.648
U305	15,5 D3 SOMT 05	15,5	20	25	117	45	50	0,175		₺1.648
U306	16 D3 SOMT 05	16	25	34	126	48	56	0,302		₺1.648
U307	16,5 D3 SOMT 06	16,5	25	34	126	48	56	0,302	SOMT 0602	₺1.648
U308	17 D3 SOMT 06	17	25	34	129	51	56	0,318	TGTC	₺1.648
U309	17,5 D3 SOMT 06	17,5	25	34	129	51	56	0,318		₺1.648
U310	18 D3 SOMT 06	18	25	34	132	54	56	0,327		₺1.648
U311	18,5 D3 SOMT 06	18,5	25	34	132	54	56	0,327		₺1.648
U312	19 D3 SOMT 06	19	25	34	135	57	56	0,330		₺1.648
U313	19,5 D3 SOMT 07	19,5	25	34	135	57	56	0,330	SOMT 07T3	₺1.707
U314	20 D3 SOMT 07	20	25	34	138	60	56	0,347	TGTC	₺1.707
U315	20,5 D3 SOMT 07	20,5	25	34	138	60	56	0,350		₺1.707
U316	21 D3 SOMT 07	21	25	34	141	63	56	0,377		₺1.707
U318	22 D3 SOMT 08	22	25	34	144	66	56	0,375		₺1.707
U319	22,5 D3 SOMT 08	22,5	25	34	144	66	56	0,375	SOMT 08T3	₺1.707
U320	23 D3 SOMT 08	23	25	34	147	69	56	0,407	TGTC	₺1.707
U321	23,5 D3 SOMT 08	23,5	25	34	147	69	56	0,412		₺1.785
U322	24 D3 SOMT 08	24	25	34	150	72	56	0,446		₺1.785
U323	24,5 D3 SOMT 08	24,5	25	34	150	72	56	0,452		₺1.785
U324	25 D3 SOMT 08	25	25	34	153	75	56	0,460		₺1.785

Kod			
U300-U306	TC058 M2x4,2	T6	
U307-U318	TC059 M2,2x5	T7	
U319-U324	TC063 M2,5x7	T8	

TGTC Ucuna Uygunur.

D4 SOMT

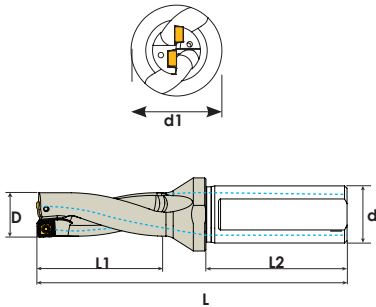

Sipariş Kodu	Ürün Kodu	Ölçüler (mm)							Uç	Fiyat
		D	d	d1	L	L1	L2	kg		
U402	14 D4 SOMT 05	14	20	25	128	56	50	0,170	SOMT 0502	₺2.084
U403	14,5 D4 SOMT 05	14,5	20	25	128	56	50	0,175	TGTC	₺2.084
U406	16 D4 SOMT 05	16	25	34	142	64	56	0,322		₺2.124
U408	17 D4 SOMT 06	17	25	34	146	68	56	0,338	SOMT 0602	₺2.124
U409	17,5 D4 SOMT 06	17,5	25	34	146	68	56	0,348	TGTC	₺2.124
U410	18 D4 SOMT 06	18	25	34	150	72	56	0,347		₺2.124
U412	19 D4 SOMT 06	19	25	34	154	76	56	0,350		₺2.124
U414	20 D4 SOMT 07	20	25	34	158	8	56	0,387	SOMT 07T3	₺2.220
U416	21 D4 SOMT 07	21	25	34	162	84	56	0,417	TGTC	₺2.220
U418	22 D4 SOMT 07	22	25	34	166	88	56	0,425		₺2.220
U420	24 D4 SOMT 08	24	25	34	174	96	56	0,486	SOMT 08T3	₺2.321
U422	25 D4 SOMT 08	25	25	34	178	100	56	0,498	TGTC	₺2.321

Kod			
U402-U406	TC058 M2x4,2	T6	
U408-U418	TC059 M2,2x5	T7	
U420-U422	TC063 M2,5x7	T8	

TGTC Ucuna Uygunur.

D2-D3 XCMT-QCMT

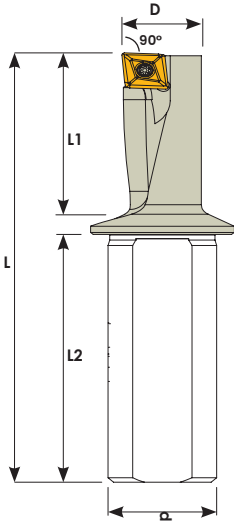
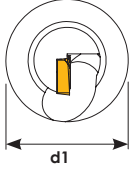
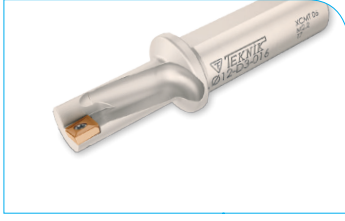

Sipariş Kodu	Ürün Kodu	Ölçüler (mm)							Uç	Fiyat
		D	d	d1	L	L1	L2			
U030	10 D2,25 QC-- 050204	10	12	16	74,5	22,5	42	0,062	QC-- 050204 KRLY	₺1.210
U032	12 D2,25 QC-- 060204	12	16	20	85	27	45	0,100	QC-- 060204 KRLY	₺1.210
U034	14 D2,25 QC-- 070304	14	16	20	90	31,5	45	0,111	QC-- 070304 KRLY	₺1.269
U036	16 D2,25 QC-- 080304	16	20	25	100	36	50	0,191	QC-- 080304 KRLY	₺1.269
U040	20 D2,25 QC-- 10T304	20	25	31	116	45	56	0,330	QC-- 10T304 KRLY	₺1.330
U042	25 D2,25 QC-- 130404	25	32	39	135	56,5	60	0,600	QC-- 130404 KRLY	₺1.429
U038	18 D2,25 XC-- 09T304	18	25	31	112	40,5	56	0,356	XCMT 09T304 ISCR	₺1.330

Kod			
U030	TC058 M2x4,2	T6	QC-- 050204
U032	TC059 M2,2x5	T7	QC-- 060204
U034	TC060 M2,5x5,5	T8	QC-- 070304
U036	TC065 M3x7	T8	QC-- 080304
U040	TC067 M3,5x8,5	T15	QC-- 10T304
U042	TC080 M4,5x11	T15	QC-- 130404
U038	TC065 M3x7	T8	XCMT 09T304

KRLY Ucuna Uygunur. (QC--)(QX--) - ISCR Ucuna Uygunur.(XCMT) ,(XCMT)

Sipariş Kodu	Ürün Kodu	Ölçüler (mm)							Uç	Fiyat
		D	d	d1	L	L1	L2			
U08	8 D2 XC-- 040104	8	12	16	68	18	42	0,056	XCMT 0401 TGTC	₺1.210
U12	10 D3 XC-- 050204	10	16	25	90	30	45	0,109	XCMT 0502	₺1.210
U14	10,5 D3 XC-- 050204	10,5	16	25	90	31	45	0,111	TGTC	₺1.210
U18	11,5 D3 XC-- 060204	11,5	16	25	92	35	45	0,113	XCMT 0602	₺1.210
U20	12 D3 XC-- 060204	12	16	25	94	36	45	0,114	TGTC	₺1.210

Kod			
U08	TC058 M2x4,2	T6	XCMT 040104
U12 - U14	TC058 M2x4,5	T6	XCMT 050204
U18 - U20	TC059 M2,2x5	T7	XCMT 060204

TGTC Ucuna Uygunur.

Alüminyum

Sipariş Kodu	Ürün Kodu	Ölçüler (mm)							Uç	Fiyat
		D	d	d1	L	L1	L2			
U32	10,5 D3 XC-- 050204	10,5	16	25	90	31	45	0,114	XCGT 050204	₺1.210
U34	11 D3 XC-- 050204	11	16	25	92	33	45	0,112	TGTC	₺1.210
U36	11,5 D3 XC-- 060204	11,5	16	25	92	35	45	0,112	XCGT 060204 TGTC	₺1.210

Kod			
U32 - U34	TC058 M2x4,5	T6	XCGT 050204
U36	TC059 M2,2x5	T7	XCGT 060204

TGTC Ucuna Uygunur.

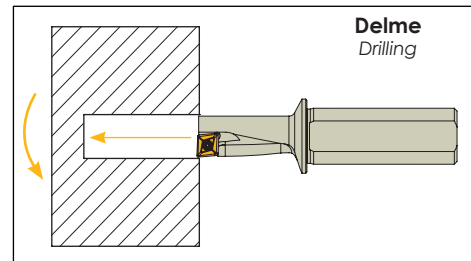
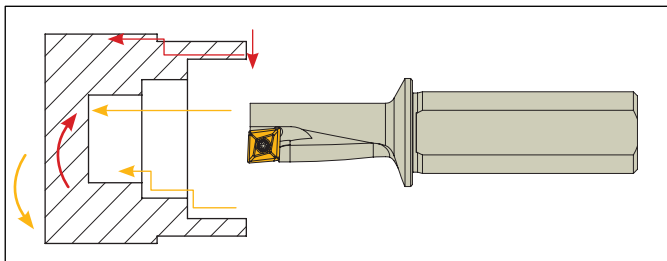

Kalite için **TEKNIK** çözüm
Technical solution for quality



THE **TEKNIK MAKİNA**®
EXCEPTIONAL CUTTING TOOLS
COLLECTION

www.teknikmakinatakim.com

Kanal Kater

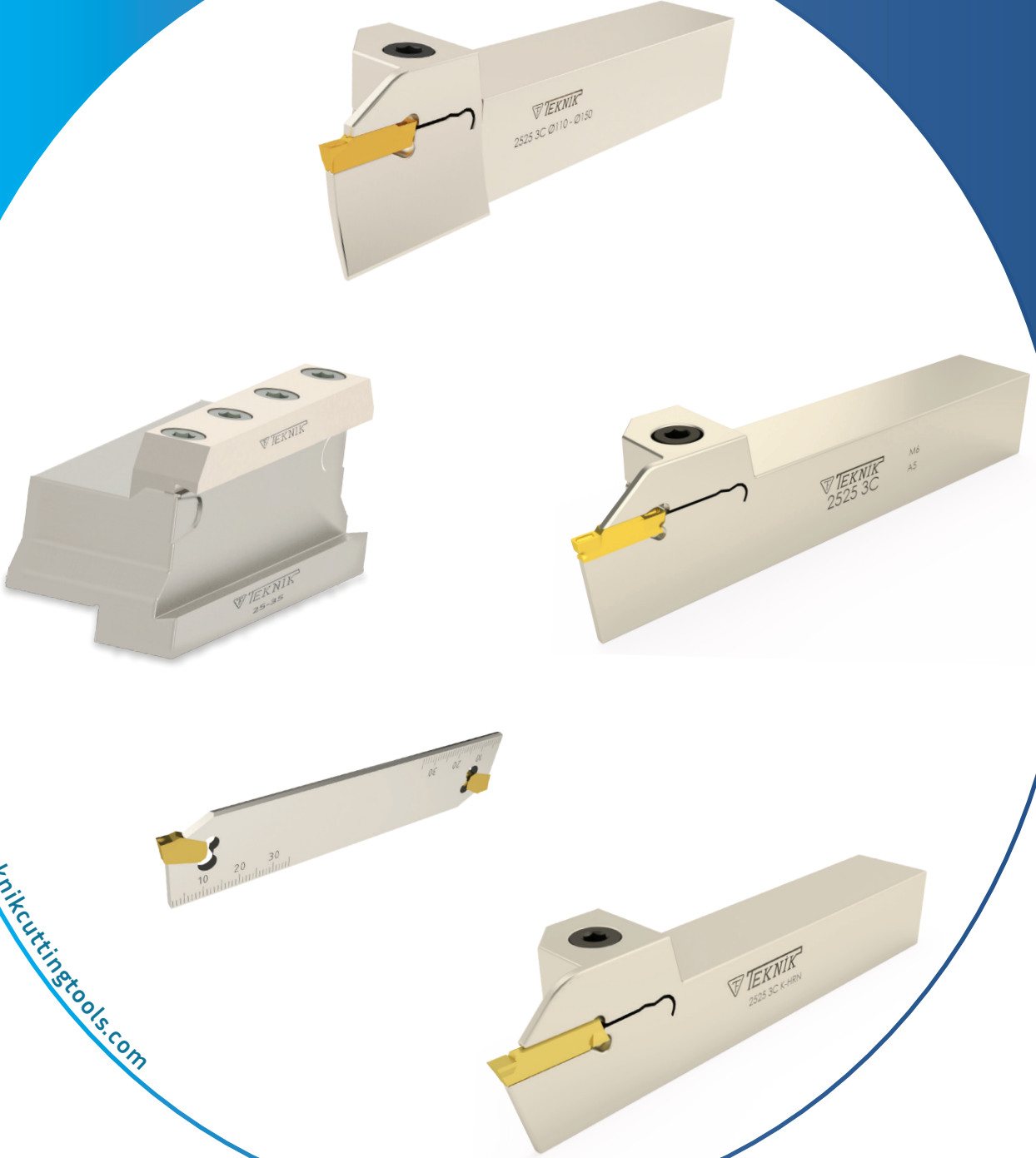

www.teknikcuttingtools.com



Kalite için TEKNİK çözüm
Technical solution for quality

138-144

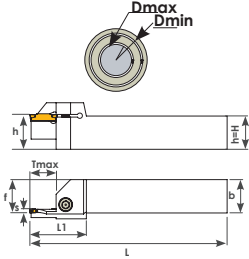

KRLY-R

Sipariş Kodu	Ürün Kodu	Ölçüler (mm)											Uç	Fiyat
		Dmin	Dmax	S	Tmax	f	b	h	L	L1				
D780	2525 3C-R (50-60)	50	60	3	17	25	25	25	150	40	0,741		₺1.110	
D782	2525 3C-R (60-80)	60	80	3	17	25	25	25	150	40	0,717	MGM 300	₺1.110	
D784	2525 3C-R (80-110)	80	110	3	17	25	25	25	150	40	0,720	KRLY.	₺1.110	
D785	2525 3C-R (110-150)	110	150	3	17	25	25	25	150	40	0,730		₺1.110	
D786	2525 4C-R (50-60)	50	60	4	20	25	25	25	150	45	0,704		₺1.110	
D788	2525 4C-R (60-80)	60	80	4	20	25	25	25	150	45	0,712	MGM 400	₺1.110	
D790	2525 4C-R (80-110)	80	110	4	20	25	25	25	150	45	0,701	KRLY.	₺1.110	
D791	2525 4C-R (110-150)	110	150	4	20	25	25	25	150	45	0,712		₺1.110	
D791-1	2525 4C (140-600)	140	600	4	25	25	25	25	150	49	0,667		₺1.110	
D792	2525 5C-R (50-80)	50	80	5	20	25	25	25	150	45	0,721		₺1.110	
D796	2525 5C-R (80-110)	80	110	5	20	25	25	25	150	45	0,716	MGM 500	₺1.110	
D798	2525 5C-R (110-150)	110	150	5	20	25	25	25	150	45	0,718	KRLY.	₺1.110	
D799-1	2525 5C-R (350-500)	350	500	5	20	25	25	25	150	45	0,713		₺1.110	
D799-2	2525 5C-R (140-600)	140	600	5	25	25	25	25	150	49	0,664		₺1.110	

TC134 M6x20

5 Allen

KRLY Ucuna Uygundur.

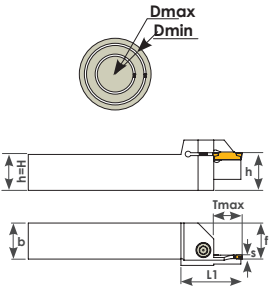
KRLY-L

Sipariş Kodu	Ürün Kodu	Ölçüler (mm)											Uç	Fiyat
		Dmin	Dmax	S	Tmax	f	b	h	L	L1				
D800	2525 3C-L (50-60)	50	60	3	17	25	25	25	150	40	0,741		₺1.110	
D802	2525 3C-L (60-80)	60	80	3	17	25	25	25	150	40	0,717	MGM 300	₺1.110	
D804	2525 3C-L (80-110)	80	110	3	17	25	25	25	150	40	0,720	KRLY	₺1.110	
D805	2525 3C-L (110-150)	110	150	3	17	25	25	25	150	40	0,730		₺1.110	
D806	2525 4C-L (50-60)	50	60	4	20	25	25	25	150	45	0,704		₺1.110	
D808	2525 4C-L (60-80)	60	80	4	20	25	25	25	150	45	0,712	MGM 400	₺1.110	
D810	2525 4C-L (80-110)	80	110	4	20	25	25	25	150	45	0,700	KRLY	₺1.110	
D811	2525 4C-L (110-150)	110	150	4	20	25	25	25	150	45	0,712		₺1.110	
D811-1	2525 4C-L (140-600)	140	600	4	25	25	25	25	150	49	0,667		₺1.110	
D812	2525 5C-L (50-80)	50	80	5	20	25	25	25	150	45	0,721		₺1.110	
D816	2525 5C-L (80-110)	80	110	5	20	25	25	25	150	45	0,716		₺1.110	
D818	2525 5C-L (110-150)	110	150	5	20	25	25	25	150	45	0,718	MGM 500	₺1.110	
D819	2525 5C-L (140-600)	140	600	5	25	25	25	25	150	49	0,664	KRLY	₺1.110	
D819-1	2525 5C-L (350-500)	350	500	5	20	25	25	25	150	45	0,713		₺1.110	

TC134 M6x20

5 Allen

KRLY Ucuna Uygundur.

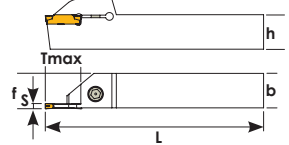
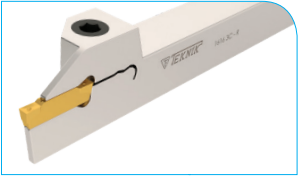
MGM/R

Sipariş Kodu	Ürün Kodu	Ölçüler (mm)							Uç	Fiyat
		h	b	S	Tmax	f	L			
D658	1212 2C-R MGM	12	12	2	16	12	125	0,162		₺696
D660	1616 2C-R MGM	16	16	2	16	16	125	0,250	MGM 200	₺736
D662	2020 2C-R MGM	20	20	2	16	20	125	0,404	KRLY	₺775
D664	2525 2C-R MGM	25	25	2	16	25	150	0,726		₺833
D666	3232 2C-R MGM	32	32	2	16	32	170	1,349		₺914
D667	1212 3C-R MGM	12	12	3	18	12	125	0,162		₺696
D668	1616 3C-R MGM	16	16	3	18	16	125	0,268	MGM 300	₺736
D670	2020 3C-R MGM	20	20	3	18	20	125	0,407	KRLY	₺775
D672	2525 3C-R MGM	25	25	3	18	25	150	0,727		₺833
D674	3232 3C-R MGM	32	32	3	18	32	170	1,280		₺914
D675	1616 4C-R MGM	16	16	4	18	16	125	0,273		₺736
D676	2020 4C-R MGM	20	20	4	18	20	125	0,408	MGM 400	₺775
D678	2525 4C-R MGM	25	25	4	18	25	150	0,727	KRLY	₺833
D680	3232 4C-R MGM	32	32	4	20	32	170	1,287		₺914
D682	2020 5C-R MGM	20	20	5	25	20	125	0,391	MGM 500	₺775
D684	2525 5C-R MGM	25	25	5	25	25	150	0,703	KRLY	₺833
D686	3232 5C-R MGM	32	32	5	25	32	170	1,268		₺914
D687	2525 6C-R MGM	25	25	6	27	25	150	0,745	MGM 600 KRLY	₺833

Kod

D658-D660,D667-D668,D675-D676

TC131 M5x16

4 Allen

D662,D670,D675-D676,D682

TC132 M5x20

D664-D666,D672-D674,D378,D680,D684,D687

TC134 M6x20

5 Allen

KRLY Ucuna Uygundur.

MGM /R

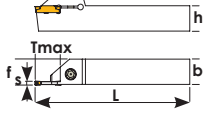
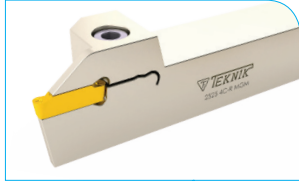

KRLY Ucuna Uygunur.

Sipariş Kodu	Ürün Kodu	Ölçüler (mm)							Uç	Fiyat
		h	b	S	Tmax	f	L	kg		
D960	2525 3C-R MGM	25	25	3	25	25	150	0,727	MGM 300	₺1.092
D963	2525 3C-R MGM	25	25	3	40	25	170	0,722	KRLY	₺1.252
D961	2525 4C-R MGM	25	25	4	25	25	150	0,727	MGM 400	₺1.092
D964	2525 4C-R MGM	25	25	4	40	25	170	0,721	KRLY	₺1.252
D962	2525 5C-R MGM	25	25	5	40	25	170	0,745	MGM 500 KRLY	₺1.252



TC134 M6x20



5 Allen



MGM /L

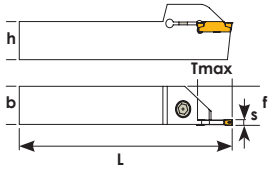
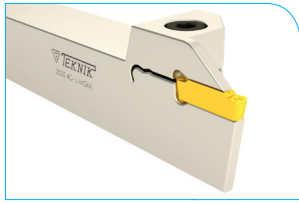

KRLY Ucuna Uygunur.

Sipariş Kodu	Ürün Kodu	Ölçüler (mm)							Uç	Fiyat
		h	b	S	Tmax	f	L	kg		
D607	1212 2C-L MGM	12	12	2	16	12	125	0,161	MGM 200	₺696
D608	1616 2C-L MGM	16	16	2	16	16	125	0,250	KRLY	₺736
D610	2020 2C-L MGM	20	20	2	16	20	125	0,404		₺775
D611	2525 2C-L MGM	25	25	2	16	25	150	0,726		₺833
D612	1616 3C-L MGM	16	16	3	18	16	125	0,268	MGM 300	₺736
D614	2020 3C-L MGM	20	20	3	18	20	125	0,407	KRLY	₺775
D615	2525 3C-L MGM	25	25	3	18	25	150	0,750		₺833
D617	2020 4C-L MGM	20	20	4	18	20	125	0,407	MGM 400	₺775
D618	2525 4C-L MGM	25	25	4	18	25	150	0,727	KRLY	₺833
D620	2525 5C-L MGM	25	25	5	25	25	150	0,703	MGM 500 KRLY	₺833
D621	2525 6C-L MGM	25	25	5	27	25	150	0,745	MGM 600 KRLY	₺833

Kod

D607-D608,D612
D610,D614,D617
D615,D618-D621



TC131 M5x16
TC132 M5x20
TC134 M6x20



4 Allen
4 5 Allen



KGMN /R

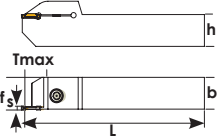
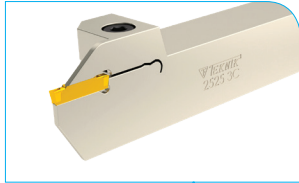

KRLY Ucuna Uygunur.

Sipariş Kodu	Ürün Kodu	Ölçüler (mm)							Uç	Fiyat
		h	b	S	Tmax	f	L	kg		
D635	2020 2C-R KGMN	20	20	2	18	20	125	0,412	KGMN 200	₺775
D636	2525 2C-R KGMN	25	25	2	18	25	150	0,726	KRLY	₺833
D637	2020 3C-R KGMN	20	20	3	20	20	125	0,406	KGMN 300	₺775
D638	2525 3C-R KGMN	25	25	3	22	25	150	0,732	KRLY	₺833
D639	2020 4C-R KGMN	20	20	4	20	20	125	0,406	KGMN 400	₺775
D640	2525 4C-R KGMN	25	25	4	22	25	152	0,737	KRLY	₺833

Kod

D635,D637,D639
D636,D638,D640



TC132 M5x20
TC134 M6x20



4 Allen
5 Allen



KGMN

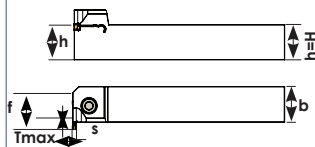
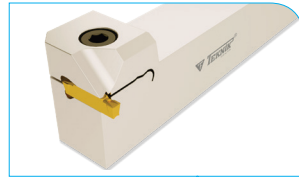

KRLY Ucuna Uygunur.

Sipariş Kodu	Ürün Kodu	Ölçüler (mm)							Uç	Fiyat
		h	b	S	Tmax	f	L	kg		
D622	2020 2C KGMN	20	20	2	3,5	23,5	125	0,412	KGMN 200	₺775
D623	2525 2C KGMN	25	25	2	3,5	28,5	150	0,833	KRLY	₺833
D624	2020 3C KGMN	20	20	3	5	25	125	0,468	KGMN 300	₺775
D625	2525 3C KGMN	25	25	3	5	30	150	0,837	KRLY	₺833
D626	2020 4C KGMN	20	20	4	5	25	125	0,463	KGMN 400	₺775
D627	2525 4C KGMN	25	25	4	5	30	150	0,464	KRLY	₺833

Kod

D622,D624,D626

D623,D625,D627



TC132 M5x20
TC134 M6x20



4 Allen
5 Allen



GRP/R

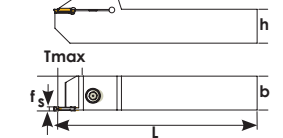
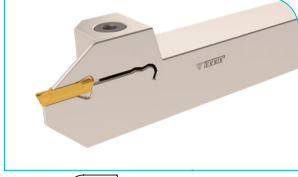

ISCR Ucuna Uygundur.

Sipariş Kodu	Ürün Kodu	Ölçüler (mm)							Uç	Fiyat
		h	b	S	Tmax	f	L	kg		
D773	2020 3C-R GRP	20	20	3	18	20	125	0,409	GRP 3C	₺775
D769	2525 3C-R GRP	25	25	3	18	25	150	0,755	ISCR	₺833
D770	2525 4C-R GRP	25	25	4	20	25	150	0,747	GRP 4C	₺833
D772	3232 4C-R GRP	32	32	4	18	32	170	1,285	ISCR	₺914
D771	2525 5C-R GRP	25	25	5	24	25	150	0,739	GRP 5C	₺833
D774	3232 5C-R GRP	32	32	5	24	32	170	1,264	ISCR	₺914
Kod										
D773		TC131 M5x20			4 Allen					
D770-D774		TC134 M6x20			5 Allen					

ISCR/R

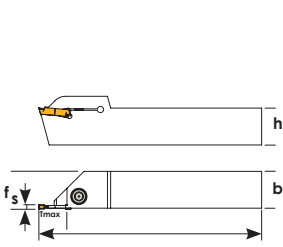
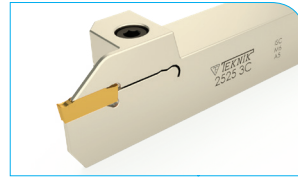

ISCR Ucuna Uygundur.

Sipariş Kodu	Ürün Kodu	Ölçüler (mm)							Uç	Fiyat
		h	b	S	Tmax	f	L	kg		
D750	1212 2C-R DGN	12	12	2	16	12	125	0,158		₺696
D752	1616 2C-R DGN	16	16	2	16	16	125	0,260	DGN 2C	₺736
D754	2020 2C-R DGN	20	20	2	18	20	125	0,398	ISCR	₺775
D756	2525 2C-R DGN	25	25	2	19	25	150	0,712		₺833
D758	1212 3C-R DGN	12	12	3	16	12	125	0,160		₺696
D760	1616 3C-R DGN	16	16	3	19	16	125	0,253	DGN 3C	₺736
D762	2020 3C-R DGN	20	20	3	20	20	125	0,394	ISCR	₺775
D764	2525 3C-R DGN	25	25	3	22	25	150	0,711		₺833
D764-1	2525 3C-R DGN	25	25	3	25	25	150	0,711		₺868
D775	2020 4C-R DGN	20	20	4	20	20	125	0,391	DGN 4C	₺775
D777	2525 4C-R DGN	25	25	4	20	25	150	0,709	ISCR	₺833
Kod										
(D750-D752),(D758-D760)		TC131 M5x16			4 Allen					
D754,D775		TC132 M5x20			5 Allen					
D756,D764,D777		TC134 M6x20								

ISCR/L

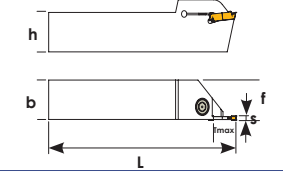
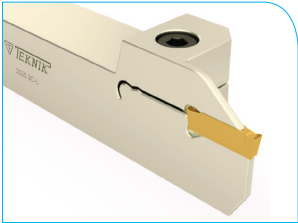

ISCR Ucuna Uygundur.

Sipariş Kodu	Ürün Kodu	Ölçüler (mm)							Uç	Fiyat
		h	b	S	Tmax	f	L	kg		
D726	1212 2C-L DGN	12	12	2	16	12	125	0,158	DGN 2C	₺696
D727	1616 2C-L DGN	16	16	2	16	16	125	0,260	ISCR	₺736
D728	2020 2C-L DGN	20	20	2	18	20	125	0,398		₺775
D729	2525 2C-L DGN	25	25	2	19	25	150	0,712		₺833
D730	1212 3C-L DGN	12	12	3	16	12	125	0,160	DGN 3C	₺696
D731	1616 3C-L DGN	16	16	3	19	16	125	0,253	ISCR	₺736
D732	2020 3C-L DGN	20	20	3	20	20	125	0,394		₺775
D733	2525 3C-L DGN	25	25	3	22	25	150	0,711		₺833
Kod										
D726-D727,D730-D731		TC131 M5x16			4 Allen					
D728,D733		TC132 M5x20								
D728-D729,D732-D733		TC134 M5x20								

ZCC/R ZT-D

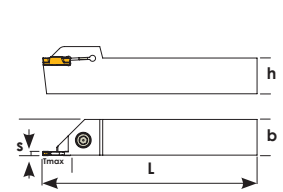
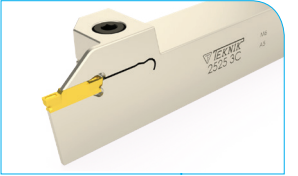

ZCC Ucuna Uygundur.

Sipariş Kodu	Ürün Kodu	Ölçüler (mm)							Uç	Fiyat
		h	b	S	Tmax	f	L	kg		
D027	1616 3C-R ZT-D	16	16	3	18	16	125	0,301	ZT.D 3C	₺736
D028	2020 3C-R ZT-D	20	20	3	18	20	125	0,394	ZCC	₺775
D030	2525 3C-R ZT-D	25	25	3	22	25	150	0,755		₺833
D036	2020 4C-R ZT-D	20	20	4	18	20	125	0,400	ZT.D 4C	₺775
D038	2525 4C-R ZT-D	25	25	4	22	25	150	0,747	ZCC	₺833
D044	2020 5C-R ZT-D	20	20	5	18	20	125	0,391	ZT.D 5C	₺775
D046	2525 5C-R ZT-D	25	25	5	18	25	150	0,734	ZCC	₺833
D049	2525 6C-R ZT-D	25	25	6	18	25	150	0,745	ZT.D 6C	₺833
D051	3232 6C-R ZT-D	32	32	6	20	32	170	1,331	ZCC	₺914
Kod										
D027		TC131 M5x16			4 Allen					
D028,D036,D044		TC132 M5x20			5 Allen					
D030,D038,D046-D051		TC134 M6x20								

TKT/R TD

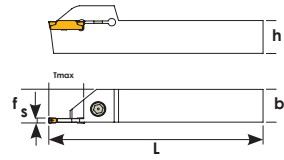

Sipariş Kodu	Ürün Kodu	Ölçüler (mm)							Uç	Fiyat	
		h	b	S	Tmax	f	L	(kg)			
D714	1212 2C-R TD	12	12	2	16	12	125	0,166	TD 2C	₺696	
D715	1616 2C-R TD	16	16	2	16	16	125	0,270	TGTC	₺736	
D716	2020 2C-R TD	20	20	2	16	20	125	0,401		₺775	
D717	2525 2C-R TD	25	25	2	18	25	150	0,728		₺833	
D718	1212 3C-R TD	12	12	2	16	12	125	0,160		₺696	
D719	1616 3C-R TD	16	16	3	18	16	125	0,256	TD 3C	₺736	
D720	2020 3C-R TD	20	20	3	18	20	125	0,398	TGTC	₺775	
D721	2525 3C-R TD	25	25	3	18	25	150	0,735		₺833	
D722	2020 4C-R TD	20	20	4	18	20	125	0,401	TD 4C	₺775	
D723	2525 4C-R TD	25	25	4	18	25	150	0,735	TGTC	₺833	
Kod											
D714-D715,D718-D719		TC131 M5x16									
D716,D720,D722		TC132 M5x20							4 Allen		
D717,D721,D723		TC134 M6x20							5 Allen		

TGTC Ucuna Uygundur.

K.HRN/R S224

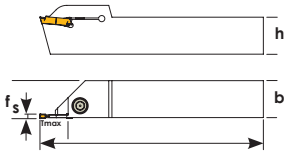
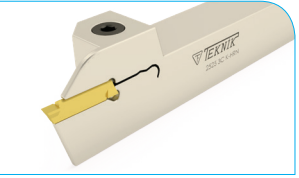

Sipariş Kodu	Ürün Kodu	Ölçüler (mm)							Uç	Fiyat	
		h	b	S	Tmax	f	L	(kg)			
D700	1616 2C-R S224	16	16	2	18	16	125	0,258	2C S224	₺736	
D701	2020 2C-R S224	20	20	2	18	20	125	0,406	K.HRN	₺775	
D702	2525 2C-R S224	25	25	2	18	25	150	0,713		₺833	
D703	1616 3C-R S224	16	16	3	18	16	100	0,260	3C S224	₺736	
D704	2020 3C-R S224	20	20	3	18	20	125	0,407	K.HRN	₺775	
D705	2525 3C-R S224	25	25	3	18	25	150	0,720		₺833	
D706	2020 4C-R S224	20	20	4	18	20	125	0,401	4C S224	₺775	
D707	2525 4C-R S224	25	25	4	18	25	150	0,737	K.HRN	₺833	
D708	2020 5C-R S224	20	20	5	18	20	125	0,401	5C S224	₺775	
D710	2525 5C-R S224	25	25	5	18	25	150	0,730	K.HRN	₺833	
Kod											
D700,D703		TC131 M5x16									
D701,D702,D704,D706,D708		TC132 M5x20							4 Allen		
D705,D707,D710		TC134 M6x20							5 Allen		

HRN Ucuna Uygundur.

B.HRN/R S229

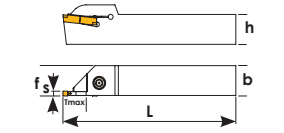
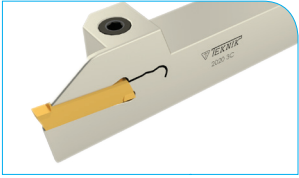

Sipariş Kodu	Ürün Kodu	Ölçüler (mm)							Uç	Fiyat	
		h	b	S	Tmax	f	L	(kg)			
D688	2020 3C-R S229	20	20	3	22	20	125	0,391	3C S229	₺775	
D690	2525 3C-R S229	25	25	3	22	25	150	0,700	B.HRN	₺833	
D692	2020 4C-R S229	20	20	4	22	20	125	0,386	4C S229	₺775	
D694	2525 4C-R S229	25	25	4	22	25	150	0,705	B.HRN	₺833	
D696	2020 5C-R S229	20	20	5	22	20	125	0,389	5C S229	₺775	
D698	2525 5C-R S229	25	25	5	22	25	150	0,709	B.HRN	₺833	
Kod											
D688-D692,D696		TC132 M5x20							4 Allen		
D690,D694,D698		TC134 M6x20							5 Allen		

HRN Ucuna Uygundur.

B.HRN/L S229

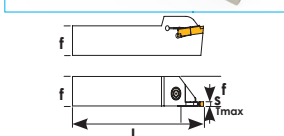
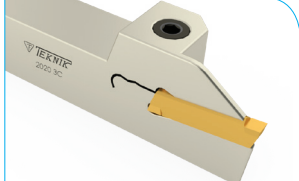

Sipariş Kodu	Ürün Kodu	Ölçüler (mm)							Uç	Fiyat	
		h	b	S	Tmax	f	L	(kg)			
D711	2525 3C-L S229	25	25	3	22	25	150	0,700	3C S229 B.HRN	₺833	
D712	2525 4C-L S229	25	25	4	22	25	150	0,705	4C S229 B.HRN	₺833	
D713	2525 5C-L S229	25	25	5	22	25	150	0,709	5C S229 B.HRN	₺833	
Kod											
D711-D713		TC134 M6x20							5 Allen		

HRN Ucuna Uygundur.

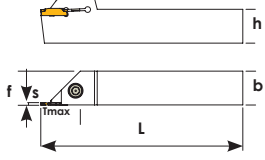
SDV 123/R

Sipariş Kodu	Ürün Kodu	Ölçüler (mm)							Uç	Fiyat	
		h	b	S	Tmax	f	L	kg			
D900	2020 2C-123 SDV-R	20	20	2	18	20	125	0,400	123 2C	₺775	
D902	2525 2C-123 SDV-R	25	25	2	18	25	150	0,732	SDV	₺833	
D904	2020 3C-123 SDV-R	20	20	3	19	20	125	0,397	123 3C	₺775	
D906	2525 3C-123 SDV-R	25	25	3	20	25	150	0,713	SDV	₺833	
D908	2020 4C-123 SDV-R	20	20	4	18	20	125	0,415	123 4C	₺775	
D910	2525 4C-123 SDV-R	25	25	4	18	25	150	0,724	SDV	₺833	
D912	2525 5C-123 SDV-R	25	25	5	18	25	150	0,725	123 SDV 5C	₺833	
Kod											
D900,D904,D908		TC132 M5x20		4 Allen							
D902,D906,D910-D912		TC134 M6x20		5 Allen							

SNDVK Ucuna Uygundur.

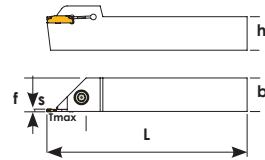
SDV 123/L

Sipariş Kodu	Ürün Kodu	Ölçüler (mm)							Uç	Fiyat	
		h	b	S	Tmax	f	L	kg			
D873	2020 2C-123 SDV-L	20	20	2	18	20	125	0,400	123 2C	₺775	
D874	2525 2C-123 SDV-L	25	25	2	18	25	150	0,732	SDV	₺833	
D875	2020 3C-123 SDV-L	20	20	3	19	20	125	0,397	123 3C	₺775	
D876	2525 3C-123 SDV-L	25	25	3	20	25	150	0,713	SDV	₺833	
D877	2020 4C-123 SDV-L	20	20	4	18	20	125	0,415	123 4C	₺775	
D878	2525 4C-123 SDV-L	25	25	4	18	25	150	0,724	SDV	₺833	
D879	2525 5C-123 SDV-L	25	25	5	18	25	150	0,725	123 5C SDV	₺833	
Kod											
D873,D875,D877		TC132 M5x20		4 Allen							
D874,D876,D878-D912		TC134 M6x20		5 Allen							

SNDVK Ucuna Uygundur.

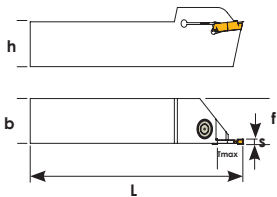
DGM 2-3

Sipariş Kodu	Ürün Kodu	Ölçüler (mm)							Uç	Fiyat	
		h	b	S	Tmax	f	L	kg			
D842	1212 2C-DGM 2	12	12	2	16	12	125	0,166		₺696	
D843	1616 2C-DGM 2	16	16	2	17	16	125	0,267	DGM 2C	₺736	
D844	2020 2C-DGM 2	20	20	2	17	20	125	0,403	TNGLY	₺775	
D845	2525 2C-DGM 2	25	25	2	17	25	150	0,739		₺833	
D847	1212 3C-DGM 3	12	12	3	16	12	125	0,168		₺696	
D848	1616 3C-DGM 3	16	16	3	17	16	125	0,263	DGM 3C	₺736	
D849	2020 3C-DGM 3	20	20	3	20	20	125	0,395	TNGLY	₺775	
D850	2525 3C-DGM 3	25	25	3	20	25	150	0,740		₺833	
Kod											
D842,D843		TC131 M5x16		4 Allen							
D844,D847-D849		TC132 M5x20		5 Allen							
D845-D850		TC134 M6x20									

TNGLY Ucuna Uygundur.

GX16-GX24

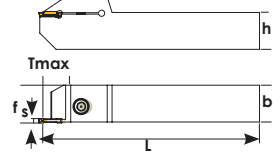
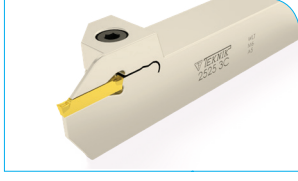

Sipariş Kodu	Ürün Kodu	Ölçüler (mm)							Uç	Fiyat
		h	b	S	Tmax	f	L			
D858	2020 2C GX16	20	20	2	18	20	125	0,267	GX 16 2C WLTR	₺775
D859	2525 2C GX16	25	25	2	18	25	150	0,403	GX 16 2C WLTR	₺833
D860	2020 3C GX16	20	20	3	20	20	125	0,395	GX 16 3C WLTR	₺775
D861	2525 3C GX16	25	25	3	22	25	150	0,740	GX 16 3C WLTR	₺833
D864	2020 2C GX24	20	20	2	18	20	125	0,403	GX 24 2C WLTR	₺775
D865	2525 2C GX24	25	25	2	18	25	150	0,739	GX 24 2C WLTR	₺833
D866	2020 3C GX24	20	20	3	20	20	125	0,395	GX 24 3C WLTR	₺775
D867	2525 3C GX24	25	25	3	22	25	150	0,740	GX 24 3C WLTR	₺833
Kod										
D858,D860,D864, D866		TC132 M5x20		4 Allen						
D859,D861,D865-D867		TC134 M6x20		5 Allen						

WLTR Ucuna Uygundur.

Diş Çap Kanal Açma Kayar Otomat Takımı

MGMN

NEW PRODUCT

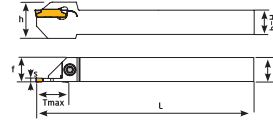

Sipariş Kodu	Ürün Kodu	Ölçüler (mm)							Uç	Fiyat
		h	b	S	Tmax	f	L			
D010	1212 2C MGMN 200	12	12	2	12	12,2	125	0,166	MGMN 200 KRLY	₺696
D011	1616 2C MGMN 200	16	16	2	16	16,2	125	0,267	MGMN 200 KRLY	₺736
D013	1212 3C MGMN 300	12	12	3	12	12,3	125	0,166	MGMN 300 KRLY	₺696
D014	1616 3C MGMN 300	16	16	3	16	16,3	125	0,267	MGMN 300 KRLY	₺736
Kod										
D010-D014		TC074 M4x10		T15						

KRLY Ucuna Uygundur.

Diş Çap Kanal Açma Kayar Otomat Takımı

KGMN

NEW PRODUCT

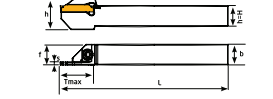

Sipariş Kodu	Ürün Kodu	Ölçüler (mm)							Uç	Fiyat
		h	b	S	Tmax	f	L			
D016	1212 2C KGMN 200	12	12	2	12	12,2	125	0,166	KGMN 200 KRLY	₺696
D017	1616 2C KGMN 200	16	16	2	16	16,2	125	0,267	KGMN 200 KRLY	₺736
Kod										
D016-D017		TC074 M4x10		T15						

KRLY Ucuna Uygundur.

Diş Çap Kanal Açma Kayar Otomat Takımı

DGN

NEW PRODUCT

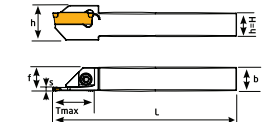

Sipariş Kodu	Ürün Kodu	Ölçüler (mm)							Uç	Fiyat
		h	b	S	Tmax	f	L			
D019	1212 2C DGN	12	12	2	12	12,2	125	0,166	DGN 2C ISCR	₺696
D020	1616 2C DGN	16	16	2	16	16,2	125	0,267	DGN 2C ISCR	₺736
D021	1212 3C-DGN	12	12	3	12	12,3	125	0,166	DGN 3C ISCR	₺696
D022	1616 3C-DGN	16	16	3	16	16,3	125	0,267	DGN 3C ISCR	₺736
Kod										
D019-D022		TC074 M4x10		T15						

ISCR Ucuna Uygundur.

MGMN

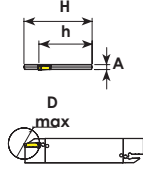
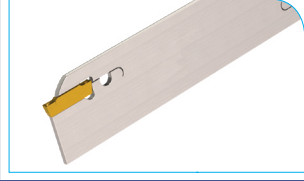

Sipariş Kodu	Ürün Kodu	Ölçüler (mm)					Uç	Fiyat
		H	h	A	L	D max		
KL29	32-2	32	25	2	150	36	MGMN 200 KRKY	₺775
KL30	32-3	32	25	2,45	150	36	MGMN 300 KRKY	₺775
KL32	32-4	32	25	3,45	150	36	MGMN 400 KRKY	₺775

KGMM

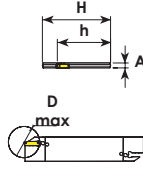
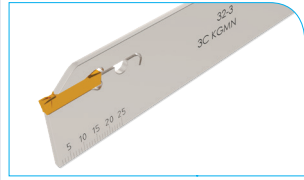

Sipariş Kodu	Ürün Kodu	Ölçüler (mm)					Uç	Fiyat
		H	h	A	L	D max		
KL37	26-2	26	21,4	1,65	110	36	KGMM 200 KRKY	₺736
KL38	26-3	26	21,4	2,45	110	36	KGMM 300 KRKY	₺736
KL39	26-4	26	21,4	3,45	110	36	KGMM 400 KRKY	₺736
KL34	32-2	32	25	1,65	150	36	KGMM 200 KRKY	₺775
KL35	32-3	32	25	2,45	150	36	KGMM 300 KRKY	₺775
KL36	32-4	32	25	3,45	150	36	KGMM 400 KRKY	₺775

SP

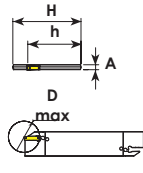
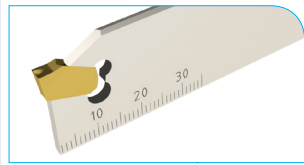

Sipariş Kodu	Ürün Kodu	Ölçüler (mm)					Uç	Fiyat
		H	h	A	L	D max		
KL40	26-3	26	21,4	2,45	110		SP 300 KRKY	₺736
KL42	26-4	26	21,4	3,45	110		SP 400 KRKY	₺736
KL44	32-3	32	25	2,45	150		SP 300 KRKY	₺775
KL45	32-4	32	25	3,45	150		SP 400 KRKY	₺775

N151-3

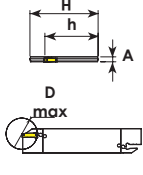
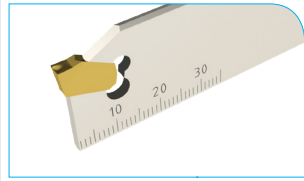

Sipariş Kodu	Ürün Kodu	Ölçüler (mm)					Uç	Fiyat
		H	h	A	L	D max		
KL52	26-3	26	21,4	2,45	110		N151-3 SDV	₺736
KL54	26-4	26	21,4	3,45	110		N151-4 SDV	₺736
KL56	32-3	32	25	2,45	150		N151-3 SDV	₺775
KL58	32-4	32	25	3,45	150		N151-4 SDV	₺775

SDV 123

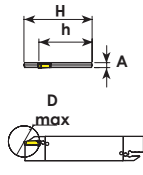
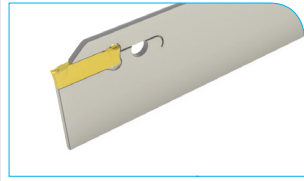

Sipariş Kodu	Ürün Kodu	Ölçüler (mm)					Uç	Fiyat
		H	h	A	L	D max		
KL60	32-3	32	25	2,45	150		123 3C SDV	₺777
KL61	32-4	32	25	3,45	150		123 4C SDV	₺777

Keski Kütüğü

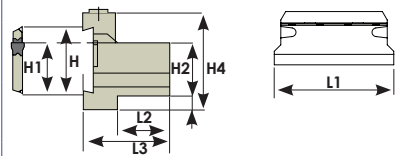

Sipariş Kodu	Ürün Kodu	Ölçüler (mm)						Fiyat
		H	L1	L2	H1	H2	L3	
KLT04	20-26	26	87	19	21,4	20	33	₺1.232
KLT05	25-26	26	110	20	24,4	25	34	₺1.232
KLT06	20-32	32	110	19	25	20	35	₺1.269
KLT08	25-32	32	110	20	25	25	36	₺1.330
KLT10	32-32	32	110	28	25	32	44	₺1.429

İç Çap Kanal Kater



www.teknikcuttingtools.com





Kalite için TEKNİK çözüm
Technical solution for quality



146-148

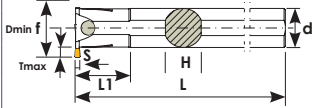

KRLY/R





Sipariş Kodu	Ürün Kodu	Ölçüler (mm)										Uç	Fiyat
		Dmin	Tmax	L	L1	d	h	f	s				
K600	S16Q 2C-R MGM	21	5	180	35	16	15	12,5	2	0,288	MGM 200	₺696	
K602	S20Q 2C-R MGM	26	5,7	180	35	20	18	15,5	2	0,440	KRLY	₺755	
K603	S25R 2C-R MGM	31	5,7	200	35	25	23	18	2	0,787		₺775	
K604	S20Q 3C-R MGM	26	6	180	35	20	18	15,5	3	0,450		₺755	
K606	S25R 3C-R MGM	32	6,7	200	40	25	23	19	3	0,784	MGM 300	₺775	
K608	S32S 3C-R MGM	38	6,1	250	60	32	30	21,5	3	1,555	KRLY	₺975	
K609	S40T 3C-R MGM	48	7,2	300	60	40	38	27	3	2,940		₺1.430	
K610	S20Q 4C-R MGM	26	6	180	35	20	18	15,5	4	0,443		₺755	
K612	S25R 4C-R MGM	31	6	200	40	25	23	18,2	4	0,783	MGM 400	₺775	
K614	S32S 4C-R MGM	38	6	250	65	32	30	21,5	4	1,552	KRLY	₺975	
K616	S40T 4C-R MGM	47	7,2	300	60	40	38	27	4	2,942		₺1.430	
K618	S25R 5C-R MGM	32	7	200	40	25	23	19,2	5	0,777	MGM 500	₺775	
K620	S32S 5C-R MGM	39	7	250	60	32	30	22,5	5	1,561	KRLY	₺975	
K622	S40T 5C-R MGM	47	7,4	300	60	40	38	27	5	2,936		₺1.430	

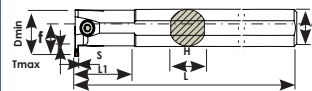

Kod			
K600-K602,K604,K610	TC130 M5x12		
K603,K606,K612,K618	TC131 M5x16	4 Allen	
K608-K609,K614-K616,K620-K622	TC134 M6x20	5 Allen	

KRLY Ucuna Uygunur.

KGMN





Sipariş Kodu	Ürün Kodu	Ölçüler (mm)										Uç	Fiyat
		Dmin	Tmax	L	L1	d	h	f	s				
K660	S16K 2C KGMN	23	6,5	125	35	16	15	14	2	0,220	KGMN 200	₺696	
K661	S20M 2C KGMN	25	6,5	150	45	20	18	15,5	2	0,374	KRLY	₺755	
K662	S25R 2C KGMN	32	7	200	45	25	23	19	2	0,802		₺775	
K663	S20M 3C KGMN	25	6,5	150	45	20	18	15,5	3	0,370	KGMN 300	₺755	
K664	S25R 3C KGMN	32	7	200	45	25	23	19	3	0,800	KRLY	₺775	
K665	S32S 3C KGMN	40	7,5	250	55	32	30	22,5	3	1,627		₺975	
K666	S20M 4C KGMN	25	6,5	150	45	20	18	15,5	4	0,374	KGMN 400	₺755	
K667	S25R 4C KGMN	32	7	200	45	25	23	19	4	0,796	KRLY	₺775	
K668	S32S 4C KGMN	40	7,5	250	55	32	30	22,5	4	1,623		₺975	

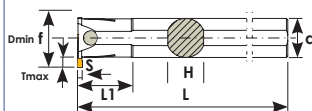

Kod			
K660-K661,K663,K666	TC130 M5x12	4 Allen	
K662,K664,K667	TC131 M5x16	5 Allen	
K665,K668	TC134 M6x20		

KRLY Ucuna Uygunur.

HRN/R S229



Sipariş Kodu	Ürün Kodu	Ölçüler (mm)										Uç	Fiyat
		Dmin	Tmax	L	L1	d	h	f	s				
K624	S25R 3C-R S229	34	9,8	200	50	25	23	21,5	3	0,766	3C S229	₺775	
K626	S32S 3C-R S229	41	9	250	50	32	30	24,5	3	1,560	B.HRN	₺975	
K628	S40T 3C-R S229	49	9	300	50	40	38	21,5	3	2,594		₺1.430	
K630	S25R 4C-R S229	34	9,8	200	50	25	23	24,5	4	0,768	4C S229	₺775	
K632	S32S 4C-R S229	42	9	250	50	32	30	23,5	4	1,656	B.HRN	₺975	
K634	S40T 4C-R S229	49	9	300	50	40	38	28,5	4	3,113		₺1.430	
K636	S25R 5C-R S229	33	9,5	200	50	25	23	21	5	0,770	5C S229	₺775	
K638	S32S 5C-R S229	41	9	250	50	32	30	24,5	5	1,659	B.HRN	₺975	
K640	S40T 5C-R S229	49	9	300	50	40	38	28,5	5	3,109		₺1.430	

Kod			
K624,K630,K636	TC131 M5x20	4 Allen	
K626-K628,K632-K634,K638-K640	TC134 M6x20	5 Allen	

HRN Ucuna Uygunur.

SDV/R 123

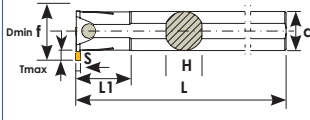
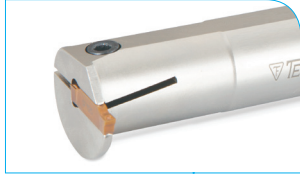

SNDVK Ucuna Uygundur.

Sipariş Kodu	Ürün Kodu	Ölçüler (mm)										Uç	Fiyat
		Dmin	Tmax	L	L1	d	h	f	s	kg			
K720	S25R 3C-R-123 SDV	32	7	200	40	25	23	19,5	3	0,784	123 3C	₺775	
K722	S32S 3C-R-123 SDV	39	7	250	60	32	30	23	3	1,567	SNDVK	₺975	
K726	S25R 4C-R-123 SDV	32	7	200	40	25	23	19,5	4	0,772	123 4C	₺775	
K728	S32S 4C-R-123 SDV	39	7	250	60	32	30	23	4	2,854	SNDVK	₺975	
K730	S25S 5C-R-123 SDV	32	7	200	40	25	23	19,5	5	0,785	123 5C	₺775	
K732	S32S 5C-R-123 SDV	39	7	250	60	32	30	19,5	5	1,564	SNDVK	₺975	
Kod													
K720,K726,K730				TC131 M5x16				4 Allen					
K722-K728,K732				TC134 M6x20				5 Allen					

HRN/R S224

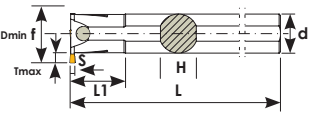
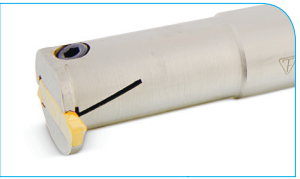

HRN Ucuna Uygundur.

Sipariş Kodu	Ürün Kodu	Ölçüler (mm)										Uç	Fiyat
		Dmin	Tmax	L	L1	d	h	f	s	kg			
K642	S20Q 2C-R S224	26	6,5	180	40	20	18	16	2	0,444	2C S224	₺755	
K644	S25R 2C-R S224	34	9	200	50	25	23	21	2	0,763	K.HRN	₺775	
K646	S20Q 3C-R S224	26	6,5	180	40	20	18	16	3	0,459	3C S224	₺755	
K648	S25R 3C-R S224	33	9	200	50	25	23	20,5	3	0,782	K.HRN	₺775	
K650	S32S 3C-R S224	40	9	250	50	32	30	24	3	1,633		₺975	
K652	S20Q 4C-R S224	26	6,5	180	40	20	18	16	4	0,440	4C S224	₺755	
K654	S25R 4C-R S224	33	9	200	50	25	23	20,5	4	0,764	K.HRN	₺775	
K656	S32S 4C-R S224	42	9	250	50	32	30	23,5	4	1,672		₺975	
Kod													
K642,K646,K652				TC130 M5x12				4 Allen					
K644,K648,K654				TC131 M5x16				5 Allen					
K650,K656				TC134 M6x20									

ZCC/R ZT.D

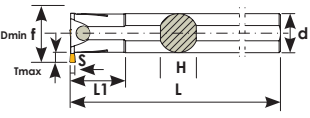

ZCC Ucuna Uygundur.

Sipariş Kodu	Ürün Kodu	Ölçüler (mm)										Uç	Fiyat
		Dmin	Tmax	L	L1	d	h	f	s	kg			
K679	S16Q 2C-R ZT.D	20	4,9	180	35	16	15	12,5	2	0,446	ZT.D 2C ZCC	₺696	
K680	S20Q 3C-R ZT.D	26	5,5	180	35	20	18	15	3	0,661	ZT.D 3C	₺755	
K681	S25R 3C-R ZT.D	33	7,5	200	35	25	23	20	3	1,576	ZCC	₺775	
K682	S32S 3C-R ZT.D	39	7	250	50	32	30	23	3	1,641		₺975	
K684	S25R 4C-R ZT.D	33	7,5	200	35	25	23	20	4	1,578	ZT.D 4C	₺775	
K685	S32S 4C-R ZT.D	39	7	250	50	32	30	23	4	1,645	ZCC	₺975	
Kod													
K679,K680				TC130 M5x12				4 Allen					
K681,K684				TC131 M5x16				5 Allen					
K682-K685				TC134 M6x20									

DGN/R

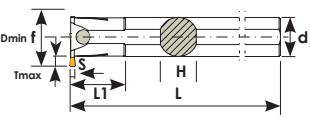



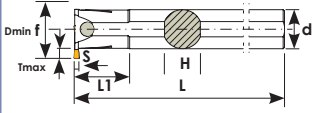

ISCR Uclarına uygundur.

Sipariş Kodu	Ürün Kodu	Ölçüler (mm)										Uç	Fiyat
		Dmin	Tmax	L	L1	d	h	f	s	kg			
K672	S20Q 3C-R DGN	25	5,5	180	35	20	18	15,0	3	0,308	DGN 3C	₺755	
K673	S25R 3C-R DGN	31	6	200	40	25	23	18,5	3	0,463	ISCR	₺775	
K674	S32S 3C-R DGN	37	6	250	55	32	30	30	3	0,809		₺975	
K676	S20Q 4C-R DGN	25	5,5	180	35	20	18	18	4	0,463	DGN 4C	₺755	
K677	S25R 4C-R DGN	31	6	200	40	25	23	23	4	0,810	ISCR	₺775	
K678	S32S 4C-R DGN	37	6	250	55	32	30	30	4	1,655		₺975	
Kod													
K672,K676				TC130 M5x12				4 Allen					
K673,K677				TC131 M5x16				5 Allen					
K674-K678				TC134 M6x20									

GRP/R





Sipariş Kodu	Ürün Kodu	Ölçüler (mm)										Uç	Fiyat
		Dmin	Tmax	L	L1	d	h	f	s				
K700	S16Q 3C-R GRP	21	4,9	180	45	16	18	12,5	3	0,308	GRP 3C	₺694	
K702	S20Q 3C-R GRP	26	6	180	35	20	18	15,7	3	0,463	ISCR	₺754	
K704	S25R 3C-R GRP	32	6,5	200	35	25	23	18,7	3	0,809		₺774	
K706	S20Q 4C-R GRP	26	5,5	180	35	20	18	15,2	4	0,463	GRP 4C	₺754	
K708	S25R 4C-R GRP	32	6,5	200	35	25	23	18,7	4	0,810	ISCR	₺774	
K710	S32S 4C-R GRP	38	6,5	250	60	32	30	22	4	1,655		₺975	

Kod			
K700,K702,K706,K708	TC130 M5x12	4 Allen	
K704,K708	TC131 M5x16	5 Allen	
K710	TC134 M6x20		

ISCR Ucuna Uygundur.

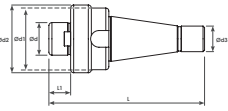
ISO 40



Sipariş Kodu	Ürün Kodu	Şaft	Ölçüler (mm)							Fiyat
			d	d2	d1	d3	L	L1		
M206	ISO 40-16	ISO 40	16	54	38	25	154	17	1,232	₺1.430
M208	ISO 40-22	ISO 40	22	54	50	25	154	19	1,371	₺1.430
M210	ISO 40-27	ISO 40	27	55	59	25	154	21	1,413	₺1.430
M212	ISO 40-32	ISO 40	32	61	67	25	154	24	1,750	₺1.430
M214	ISO 40-40	ISO 40	40	61	73	25	154	27	1,956	₺1.430

ISO 50

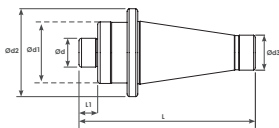

Sipariş Kodu	Ürün Kodu	Şaft	Ölçüler (mm)							Fiyat
			d	d2	d1	d3	L	L1		
M216	ISO 50-22	ISO 50	22	98	52	39	196	19	3,640	₺2.210
M218	ISO 50-27	ISO 50	27	98	61	39	196	21	3,976	₺2.210
M220	ISO 50-32	ISO 50	32	98	68	39	196	24	3,817	₺2.210
M222	ISO 50-40	ISO 50	40	98	98	39	196	27	4,512	₺2.210
M224	ISO 50-60	ISO 50	60	108	108	39	196	26	5,562	₺2.210

Mini Kanal Kater

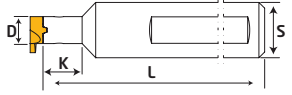

Sipariş Kodu	Ürün Kodu	Ölçüler (mm)					Uç	Fiyat
		S	D	K	L	kg		
K801	S12 D5,9 K24 L080	12	5,9	24	80	0,143	NFTG 08 KRLY	₺755
K802	S12 D08 K33 L095	12	8	33	98	0,126	NFTG 11 KRLY	₺755
K803	S12 D09 K45 L110	12	9	45	110	0,120	NFTG 14 KRLY	₺755
K804	S12 D11 K48 L130	12	11	48	130	0,348	NFTG 16 KRLY	₺755
Kod								
K801		TC063 M2,5x7						
K802		TC069 M3,5x8,5						
K803		TC074 M4x10						
K804		TC085 M5x12						

KRLY Ucuna Uygunur.

Mini Kanal Kater

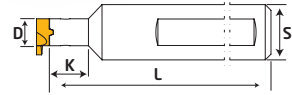

Sipariş Kodu	Ürün Kodu	Ölçüler (mm)					Uç	Fiyat
		S	D	K	L	kg		
K810	S16 D08 K11 L093	16	8	11	93	0,098	D08	₺755
K812	S16 D09 K20 L093	16	9	20	93	0,102	D09	₺755
K814	S16 D06 K11 L081	16	6	11	81	0,082	D06	₺755
K816	S20 D14 K49 L160	20	14	49	160	0,367	D14	₺794
Kod								
K810		TC069 M3,5x8,5						
K812		TC074 M4x10						
K814		TC063 M2,5x7						
K816		TC085 M5x12						

MINI TOOL

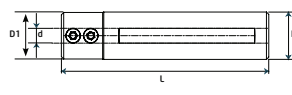
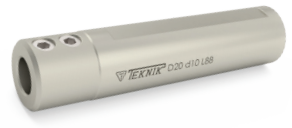

Sipariş Kodu	Ürün Kodu	Ölçüler (mm)					Fiyat	
		D	d	L	D1	kg		
DC304	D16 d03 L88	16	3	88	19,65	0,134	M6x50 M6x8	₺683
DC306	D20 d03 L88	20	3	88	19,65	0,228	M6x50 M6x8	₺683
DC310	D12 d04 L88	12	4	88	11,65	0,075	M6x50 M6x5	₺683
DC312	D16 d04 L75	16	4	75	19,65	0,139	M6x35 M6x8	₺683
DC314	D16 d04 L88	16	4	88	19,65	0,159	M6x50 M6x8	₺683
DC316	D20 d04 L88	20	4	88	19,65	0,222	M6x50 M6x8	₺683
DC318	D22 d04 L88	22	4	88	21,65	0,274	M6x50 M6x8	₺683
DC320	D12 d05 L88	12	5	88	11,65	0,067	M6x50 M6x5	₺683
DC322	D16 d05 L75	16	5	75	19,65	0,135	M6x35 M6x8	₺683
DC324	D16 d05 L88	16	5	88	19,65	0,153	M6x50 M6x8	₺683
DC326	D20 d05 L88	20	5	88	19,65	0,221	M6x50 M6x8	₺683
DC328	D22 d05 L88	22	5	88	21,65	0,274	M6x50 M6x8	₺683
DC334	D20 d06 L88	20	6	88	19,65	0,227	M6x50 M6x8	₺683
DC340	D20 d07 L88	20	7	88	19,65	0,219	M6x50 M6x8	₺683
DC344	D16 d08 L88	16	8	88	19,65	0,142	M6x50 M6x8	₺683
DC346	D20 d08 L88	20	8	88	19,65	0,214	M6x50 M6x5	₺683
DC350	D16 d10 L88	16	10	88	19,65	0,130	M6x50 M6x5	₺683
DC352	D20 d10 L88	20	10	88	19,65	0,201	M6x50 M6x5	₺683

CKJNR



Sipariř Kodu	Ürün Kodu		Uç	Fiyat
RD018	CKJNR 20x20 K16	Altlıklı	KNUX 16	₺673
RD014	CKJNR 25x25 M16	Altlıklı	ISO	₺693
RD013	CKJNR 32x32 P16	Altlıklı		₺800

CKJNL



Sipariř Kodu	Ürün Kodu		Uç	Fiyat
RD038	CKJNL 20x20 K16	Altlıklı	KNUX 16	₺673
RD034	CKJNL 25x25 M16	Altlıklı	ISO	₺693
RD032	CKJNL 32x32 P16	Altlıklı		₺800

CKUNR

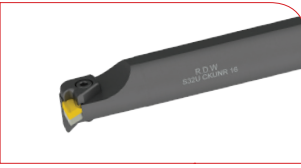

Sipariř Kodu	Ürün Kodu		Uç	Fiyat
RK750	S25S CKUNR 16	Altlıklı		₺771
RK752	S28T CKUNR 16	Altlıklı		₺819
RK754	S32U CKUNR 16	Altlıklı	KNUX 16	₺1.014
RK756	S40V CKUNR 16	Altlıklı	ISO	₺1.248
RK758	S45V CKUNR 16	Altlıklı		₺1.317
RK760	S50W CKUNR 16	Altlıklı		₺1.541

Torna Kateri



Sipariř Kodu	Ürün Kodu		Uç	Fiyat
RP100	TORNA KATERİ	6x18		₺780
RP102	TORNA KATERİ	8x10	HSS KALEM	₺780
RP104	TORNA KATERİ	10x12		₺780
RP106	TORNA KATERİ	12x14		₺839

Kesme Kateri

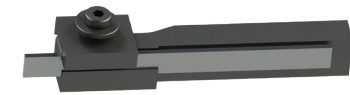

Sipariř Kodu	Ürün Kodu		Uç	Fiyat
RP110	KESME KATERİ	1/2	12 HSS KALEM	₺732
RP112	KESME KATERİ	5/8	16 HSS KALEM	₺732
RP114	KESME KATERİ	3/4	20 HSS KALEM	₺732
RP116	KESME KATERİ	7/8	22 HSS KALEM	₺780
RP118	KESME KATERİ	1"	25 HSS KALEM	₺780

Tekli - Çiftli Tirtil Kateri



Sipariř Kodu	Ürün Kodu		Uç	Fiyat
RP122	25x25 TEKLİ TIRTIL KATERİ		20x10x6	₺576
RP120	25x25 ÇİFTLİ TIRTIL KATERİ		HSS 20x10x6	₺741



Sipariř Kodu	Ürün Kodu	Fiyat
700	SN 50 TORNA KALEMLİĐİ	₺4.359
710	SN 50 CİVATASI M14	₺46
709	SN 50 CİVATASI M16	₺46
711	SN 71 CİVATASI M16	₺46
712	SN 50 KALEMLİK ANAHTARI	₺878
713	SN 71 KALEMLİK ANAHTARI	₺917

Yedek Parça



www.teknikcuttingtools.com









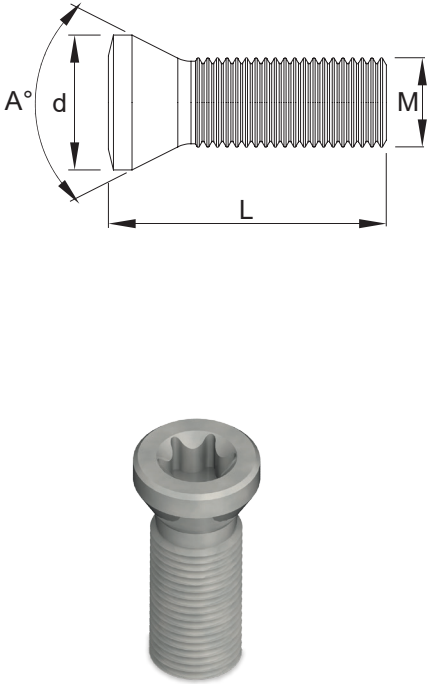
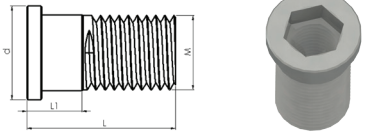

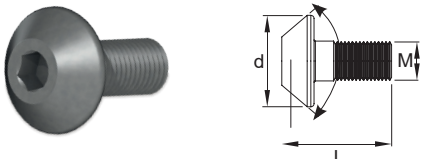

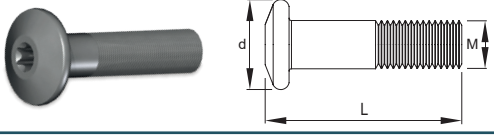
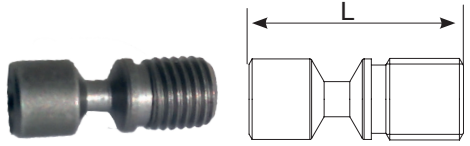

Kalite için TEKNİK çözüm
Technical solution for quality

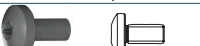

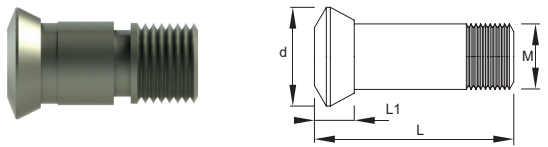





152-155

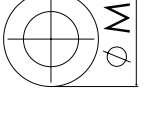

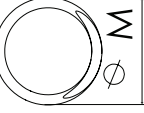

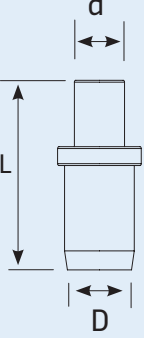

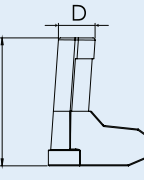



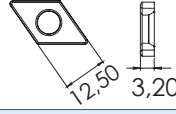

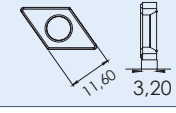

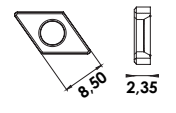

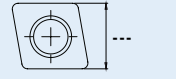

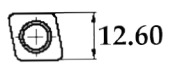

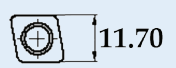

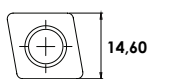

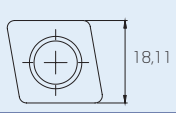

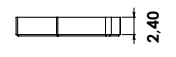

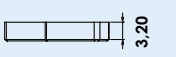

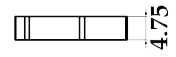



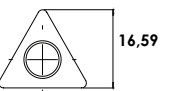

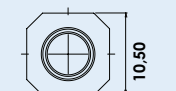



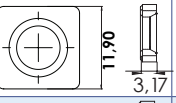

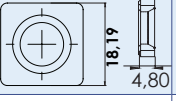

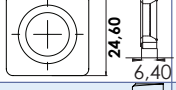
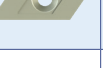

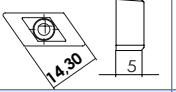

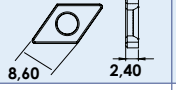







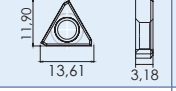





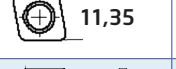

Parça	Kod	M	L	d	A	Anahtar	Fiyat
	TC057	M1,6	3,4	2,6	60°	T6	₺59
	TC057-1	M1,8	4,1	2,5	60°	T6	₺59
	TC058	M2	4,2	2,8	60°	T6	₺59
	TC058-1	M2	5	2,8	60°	T6	₺59
	TC058-2	M2,2	6	3	60°	T7	₺59
	TC059	M2,2	5	3	60°	T7	₺59
	TC059-1	M2,5	4,7	3,5	60°	T8	₺12
	TC060	M2,5	5,5	3,5	60°	T8	₺12
	TC061	M2,5	6,5	3,5	50°	T8	₺12
	TC063	M2,5	7	3,5	60°	T8	₺12
	TC092	M2,5	5,5	3,8	60°	T8	₺12
	TC093	M2,5	7	3,8	60°	T8	₺12
	TC064	M3	6,2	3,8	60°	T8	₺12
	TC065	M3	7	4,2	60°	T8	₺12
	TC065-1	M3	7	4	60°	T8	₺12
	TC066	M3	10	5,3	55°	T15	₺12
	TC067	M3,5	8,5	5,3	60°	T15	₺12
	TC068	M3,5	11	5,3	60°	T15	₺12
	TC069	M3,5	8,5	4,8	60°	T10	₺12
	TC071	M3,5	7	5,3	60°	T15	₺12
	TC072	M4	10	5,5	60°	T15	₺12
	TC073	M4	8,5	5,5	60°	T15	₺12
	TC074	M4	10	5,5	60°	T15	₺12
	TC075	M4	11	7	60°	T15	₺12
	TC076	M4	12,5	5,5	60°	T15	₺12
	TC077	M4	15	6,8	60°	T15	₺12
	TC078	M4	11	6,7	60°	T15	₺12
	TC079	M4	11	5,2	45°	T15	₺12
	TC080	M4,5	11	6,2	60°	T15	₺12
	TC083	M5	12	7	60°	T20	₺12
	TC085	M5	12	6,6	75°	T20	₺12
	TC086	M5	18	7,5	60°	T20	₺12
	TC048	M5	9	6,3		4 Allen	₺42
	TC049	M5	7,7			3,5 Allen	₺42
	TC049-1	M6	10			4 Allen	₺42

Parça	Kod	M	L	d	Anahtar	Fiyat
	TC050	M6	14	11,2	3 Allen	₺12
	TC052	M6	17	14	4 Allen	₺12
	TC054	M8	24	17,1	5 Allen	₺12
	TC056	M8 (sol-left)	24	17,1	5 Allen	₺12
	TC300	M8	21		4 Allen	₺49
	TC044	M6	27	11	3 Allen	₺12
	TC046	M5	26	10	3 Allen	₺12
	TC047	M8	29	13,6	5 Allen	₺42
	TH512	M5	12		2 Allen	₺57
	TH613	M6	13,4		2,5 Allen	₺57
	TH617	M6	17		2 Allen	₺57
	TH818	M8	18		3 Allen	₺57
	TH821	M8	21		3 Allen	₺57
	TH822	M8	22		2,5 Allen	₺57
	TH825	M8	25		3 Allen	₺57
	TC036	M3	10	5,6	T10	₺7
	TC038	M4	10	7,30	T15	₺7
	TC039	M6	12	10,6	4 Allen	₺7
	TC040	M3,5	10	8	T15	₺7
	TC062	M3	6,7	5,5	T15	₺14
	TC053	M4	9	6,5	T20	₺14
	TC053-1	M4	9	6,5	T15	₺14
	TC095	M5	12	9,5	3 Allen	₺7
	TC170	M3	7	4,2	T8	₺7
	TC172	M4	9	5,8	T15	₺7
	TC174	M5	10	7	T20	₺16
	TC176	M5	12	7,3	T20	₺16
	TC178	M5	16	7,8	3 Allen	₺16
	TC181	M6	22	9,5	3 Allen	₺62
	TC184	M8	25	13	4 Allen	₺62

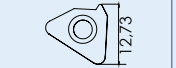









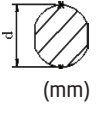

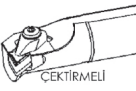







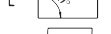

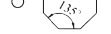



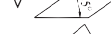









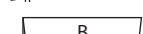

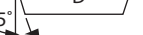

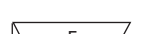

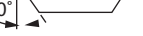

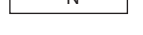
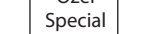



















Kod	Tip	Parça	Ölçüler (mm)	Fiyat
			M	
BK017	DNMG 11			₺77
BK017-1	TNMG 16			₺77
BK018	CNMG 16			₺96
BK019	WNMG 06			₺77
BK020	DNMG 15 CNMG 12 SNMG 12			₺77
BK021	VNMG 16			₺77
BK022	TNMG 16			₺77
BK023	TNMG 22			₺77
BK024	DNMG 11 (Small)			₺77
BK025	CNMG 19			₺96
BK027	SNMG 25			₺108
BK026	WNMG 08			₺77
BK028	KNUX Sağ/ Right			₺96
BK030	KNUX/Left			₺96
BK035	RDMT 16			₺74
BK036	TPKN16			₺74
BK300	OFCR 07			₺78









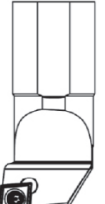

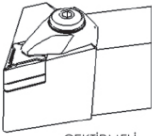
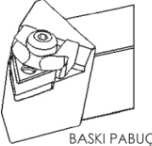
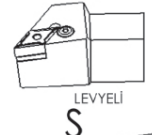
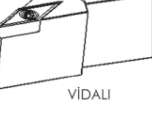

















































Kod	Tip	Parça	Ölçüler (mm)	Fiyat	
			M		
BSP010	Baskı Pulu			₺7	
BSP030	Baskı Pulu (Normal)			₺7	
BSP031	Baskı Pulu			₺7	
BSP032	Baskı Pulu			₺7	
BY040	M6			₺7	
BY041	M5			₺7	
BY042	M6			₺7	
BY043	M5			₺7	
BY044				₺7	
BSP020	TNMG 16 WNMG 06	D:5 d:3,5 L:14,5			₺31
BSP021	TNMG 22 DNMG 11 WNMG 08	D:6 d:5 L:15			₺31
TL3	L12,2-D3,5			₺116	
TL3B	L10-D3			₺116	
TL4	L13-D4,5			₺116	
TL4A	L10,5-D4,7			₺116	
TL4B	L15,6-D5			₺116	
TS-3	D6,65-L5,5				
TS-4	D7,71-L7	₺49			

Kod	Tip	Parça	Ölçüler (mm)	Fiyat
			M	
TA014	DNMG 15 Shim			₺88
TA014-1	DNMG 15 Shim			₺88
TA013	DNMG 11 Shim			₺78
TA023	CNMG 09 Shim			₺78
TA016	CNMG 12 Shim			₺88
TA016-1	CNMG 12 Shim			₺88
TA022	CNMG 16 Shim			₺105
TA017	CNMG 19 Shim			₺186
TA021	WNMG 06 Shim			₺78
TA020-1	WNMG 08 Shim			₺85
TA020	WNMG 08 Shim			₺117
TA019	TNMG 16 Shim			₺74
TA045	TNMG 22 Shim			₺124
TA052	SEET 12 Shim			₺78

Kod	Tip	Parça	Ölçüler (mm)	Fiyat
			M	
TA050	SNMG 12 Shim			₺88
TA051	SNMG 19 Shim			₺160
TA053	SNMG 25 Shim			₺186
TA046	KNUX RIGHT Shim			₺124
TA048	KNUX LEFT Shim			₺124
TA030	DCMT 11 Shim			₺78
TA034	VBMT 16 Shim			₺88
TA032	VCMT 16 Shim			₺88
TA033	VNMG 16 Shim			₺88
TA010	TPKN 16 Shim			₺78
TA012	TPKN 22 Shim			₺88
TA015	CCMT 09 Shim			₺78
TA015-1	CCMT 12 Shim			₺88
TA040	ER 16 Shim			₺78
TA061	16 ER Shim			₺94
TA060	16 IR Shim			₺94
TA062	22 ER Shim			₺105
TA063	22 IR Shim			₺105
TA064	27 ER Shim			₺215
TA065	27 IR Shim			₺215

S 32 T D D U N R 15

1	2	3	4	5	6	7	8	9							
Type of Shank Schaftansführung	Shank Schaft	Tool Length Werkzeuglänge	Clamping System Klemmsystem	Uç Form WSP-Form	Tool Type Shank Werkzeugtyp	Insert Clearance WSP-Freiwinkel	Holder Execution Bearbestungsrichtung	Cutting Edge WSP-Größe							
A: Çelik Gövdeli içten Sogutmalı Coolan Through Steel Shank Mit Kühlbohrung			<p>D</p>  ÇEKİRMELİ	<p>A </p> <p>B </p> <p>C </p> <p>D </p> <p>E </p> <p>H </p> <p>K </p> <p>L </p> <p>M </p> <p>O </p> <p>P </p> <p>R </p> <p>S </p> <p>T </p> <p>V </p> <p>W </p>	<p>F </p> <p>L </p> <p>Q </p> <p>S </p> <p>U </p> <p>W </p> <p>Z </p> <p>X = ÖZEL Special Sonderform</p>	<p></p> <p></p> <p></p> <p></p> <p></p> <p></p> <p></p> <p></p> <p></p> <p></p> <p></p> <p></p> <p></p> <p></p> <p></p> <p></p> <p></p> <p></p> <p></p> <p></p> <p></p> <p></p>	<p>R</p> 	<p>A </p> <p>B </p> <p>C </p> <p>D </p> <p>E </p> <p>K </p> <p>L </p> <p>M </p> <p>O </p> <p>P </p> <p>R </p> <p>S </p> <p>T </p> <p>V </p> <p>W </p>							
	C: Toz Metal Gövdeli Hardmetal Shank Hartmetall Stahlkopf	06 = 6							D = 60	<p>M</p>  BASKI PABUÇLU				<p>R</p>	
		08 = 8							E = 70						
		10 = 10							F = 80						
		12 = 12							G = 90						
		14 = 14							H = 100						
		16 = 16							J = 110						
		20 = 20							K = 125						
		22 = 22							L = 140						
		25 = 25							M = 150						
32 = 32		N = 160													
40 = 40	P = 170														
50 = 50	Q = 180														
E: Toz Metal Gövdeli içten Sogutmalı Hardmetal Shank Sogutmalı Hole Hartmetall Schaft mit Stahlkopf und Kühlbohrung		R = 200	<p>P</p>  LEVYELİ				<p>R</p>								
		S = 250													
		T = 300													
		U = 350													
		V = 400													
		W = 450													
		Y = 500													
		X = ÖZEL Special Sonderform													
S: Çelik Gövdeli Steel Shank Stahl Schaft			<p>S</p>  VIDALI				<p>L</p> 								

	D	D	J	N	R	20	20	K	15
	1	2	3	4	5	6	7	8	9
Clamping Sistem KlemmSistem	Cutting Style Plattenform	Type Werkzeugtyp	Clearance angle WSP-Freiwinkel	Holder Execution Bearbeitungs- richtung	Height of Shank Schaftquer- schnitts	Width of Shank Schaftbreite	Leng of Holder Werkzeuglänge	Leng of Holder Werkzeuglänge	
<p>D</p>  <p>M</p>  <p>P</p>  <p>S</p> 	<p>A </p> <p>B </p> <p>C </p> <p>D </p> <p>E </p> <p>H </p> <p>K </p> <p>L </p> <p>M </p> <p>O </p> <p>P </p> <p>R </p> <p>S </p> <p>T </p> <p>V </p> <p>W </p>	<p>A </p> <p>B </p> <p>C </p> <p>D </p> <p>E </p> <p>F </p> <p>G </p> <p>J </p> <p>K </p> <p>L </p> <p>N </p> <p>P </p> <p>Q </p> <p>R </p> <p>S </p> <p>V </p>	<p>A </p> <p>B </p> <p>C </p> <p>D </p> <p>E </p> <p>F </p> <p>G </p> <p>P </p> <p>N </p> <p>O </p>	<p>L </p> <p>R </p> <p>N </p>	<p>06 = 6</p> <p>08 = 8</p> <p>10 = 10</p> <p>12 = 12</p> <p>14 = 14</p> <p>16 = 16</p> <p>20 = 20</p> <p>22 = 22</p> <p>25 = 25</p> <p>32 = 32</p> <p>40 = 40</p> <p>50 = 50</p>	<p>06 = 6</p> <p>08 = 8</p> <p>10 = 10</p> <p>12 = 12</p> <p>14 = 14</p> <p>16 = 16</p> <p>20 = 20</p> <p>22 = 22</p> <p>25 = 25</p> <p>32 = 32</p> <p>40 = 40</p> <p>50 = 50</p>	<p>D = 60</p> <p>E = 70</p> <p>F = 80</p> <p>G = 90</p> <p>H = 100</p> <p>J = 110</p> <p>K = 125</p> <p>L = 140</p> <p>M = 150</p> <p>N = 160</p> <p>P = 170</p> <p>Q = 180</p> <p>R = 200</p> <p>S = 250</p> <p>T = 300</p> <p>U = 350</p> <p>V = 400</p> <p>W = 450</p> <p>Y = 500</p> <p>X = ÖZEL Special Sonderform</p>	<p>A </p> <p>B </p> <p>C </p> <p>D </p> <p>E </p> <p>K </p> <p>L </p> <p>M </p> <p>O </p> <p>P </p> <p>R </p> <p>S </p> <p>T </p> <p>V </p> <p>W </p>	

